

# MX150L ASSEMBLY INSTRUCTIONS

## CONNECTOR PLUG ASSEMBLY

### TERMINAL INSERTION

1. Begin assembly of the crimped male terminals into the plug housing by making sure the Terminal Position Assurance feature (TPA) is in the pre-locked position (See Figure 1).
  - Since the TPA is recessed in housing, the most accurate way to determine if it is in pre-lock position is to measure. In pre-locked position, the dimension between plug housing face and TPA is approximately 0.500" (12,7mm).
  - If it is not in pre-locked position, insert the tips of a pair of needle nose pliers into the two "D" shaped holes in the center of the TPA. Carefully, pull gently on the TPA until it starts moving. Pull to first stop. **CAUTION: DO NOT PULL TPA COMPLETELY OUT OF HOUSING. THIS MAY BREAK RETENTION FEATURES AND RESULT IN REDUCED TPA RETENTION IN HOUSING.** You are now ready to insert terminals and/or circuit plugs.

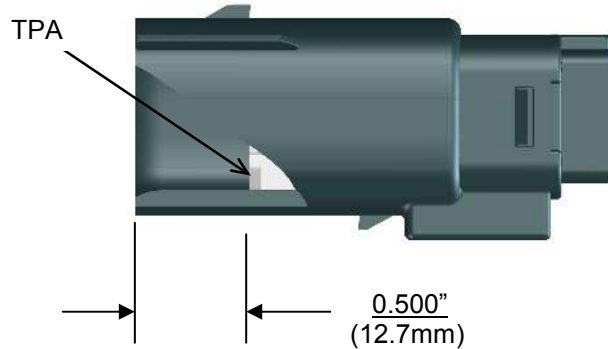

Figure 1: TPA in Pre-Locked Position

2. The terminal must be positioned correctly when inserted into the housing to assure proper latching and retention. Orient the key on the back of the male terminal with the keyway on the rear of the housing (See Figure 2). Insert the terminal into the housing until it clicks and a slight pull back on the wire is met with resistance from terminal retention feature.

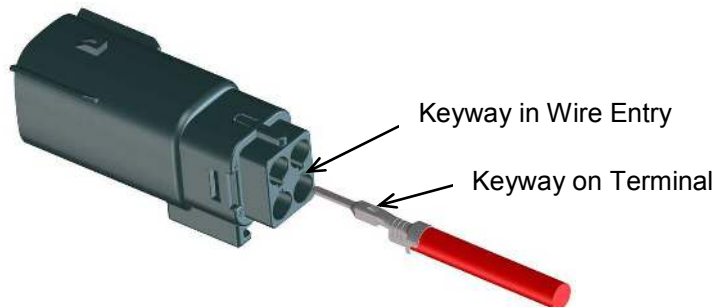

Figure 2: Terminal Orientation

REVISION: <b>B</b>	ECR/ECN INFORMATION: EC No: <b>IPG2013-0274</b> DATE: <b>2012 / 08 / 22</b>	TITLE: <b>ASSEMBLY INSTRUCTIONS FOR MX150L SEALED CONNECTOR SYSTEM</b>	SHEET No. <b>1 of 5</b>
DOCUMENT NUMBER: <b>AS-19417-001</b>	CREATED / REVISED BY: <b>WLEUNG</b>	CHECKED BY: <b>DTITUS</b>	APPROVED BY: <b>DTITUS</b>

# MX150L ASSEMBLY INSTRUCTIONS

3. Repeat Step 2 until all terminals are inserted into the housing. If a terminal is inadvertently assembled into the wrong position, use service tool to remove.
4. If using a circuit plug to seal an unused circuit, apply the same procedure as terminal insertion above. Insert the circuit plug until it clicks **once** and a slight pull back on the circuit plug is met with resistance from terminal retention feature.
  - DO NOT continue to push the circuit plug after the audible click. The circuit plug should rest on the first stop in the connector plug housing.
  - In its final position, the dimension between the plug housing and the circuit plug is approximately 0.285" (7,24mm) (See Figure 3 & Figure 4).

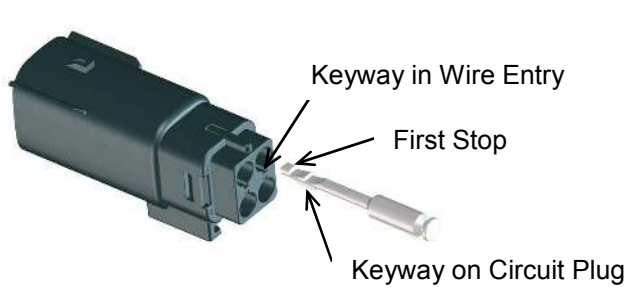

Figure 3: Circuit Plug Orientation

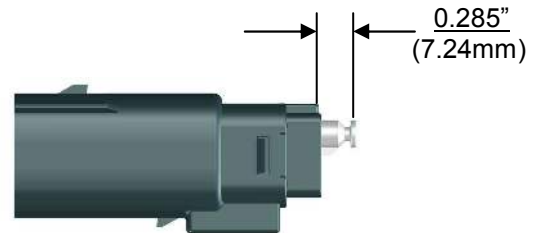

Figure 4: Circuit Plug in Final Position

5. When all terminals and/or circuit plugs are in their proper location, push down on TPA until it clicks into place and is now approximately 0.700" (17.8mm) from mating edge of outer housing (See Figure 5).

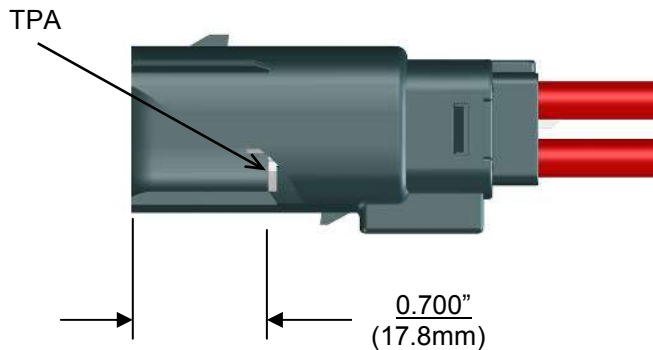

Figure 5: TPA in Locked Position

REVISION: <b>B</b>	ECR/ECN INFORMATION: EC No: IPG2013-0274 DATE: 2012 / 08 / 22	TITLE: <b>ASSEMBLY INSTRUCTIONS FOR MX150L SEALED CONNECTOR SYSTEM</b>	SHEET No. <b>2 of 5</b>
DOCUMENT NUMBER: <b>AS-19417-001</b>	CREATED / REVISED BY: <b>WLEUNG</b>	CHECKED BY: <b>DTITUS</b>	APPROVED BY: <b>DTITUS</b>

# MX150L ASSEMBLY INSTRUCTIONS

## CONNECTOR RECEPTACLE ASSEMBLY

### TERMINAL INSERTION

1. Begin assembly of the crimped female terminals into the receptacle housing by making sure the Terminal Position Assurance feature (TPA) is in the pre-locked position (See Figure 6).
  - In pre-locked position, the dimension between receptacle housing face and TPA is approximately 0.160" (4,06mm).
  - If it is not in the pre-locked position, insert the blade of a screwdriver into the slots in the TPA found adjacent or opposite to the latch. Apply slight pressure and pry the TPA out until it clicks (See Figure 7). You are now ready to insert terminals and/or circuit plugs.

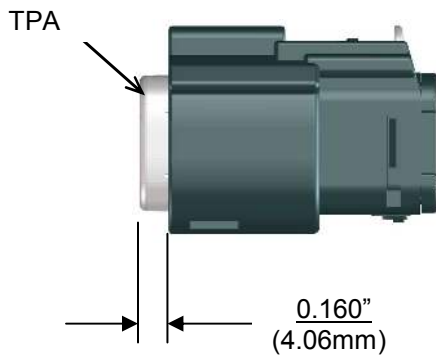

Figure 6: TPA in Pre-Lock Position



Figure 7: TPA Slots

2. The terminal must be positioned correctly when inserted into the housing to assure proper latching and retention. Orient the key on the back of the female terminal with the keyway on the wire entry cavity in the rear of the housing (See Figure 8). Insert the terminal into the housing until it clicks and a slight pull back on the wire is met with resistance from terminal retention feature.

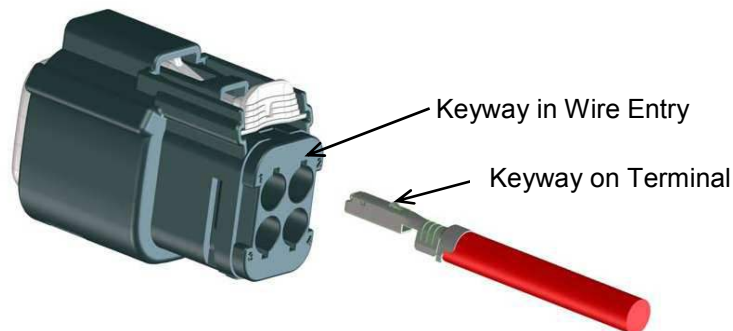

Figure 8: Terminal Orientation

REVISION: <b>B</b>	ECR/ECN INFORMATION: EC No: <b>IPG2013-0274</b> DATE: <b>2012 / 08 / 22</b>	TITLE: <b>ASSEMBLY INSTRUCTIONS FOR MX150L SEALED CONNECTOR SYSTEM</b>	SHEET No. <b>3 of 5</b>
DOCUMENT NUMBER: <b>AS-19417-001</b>	CREATED / REVISED BY: <b>WLEUNG</b>	CHECKED BY: <b>DTITUS</b>	APPROVED BY: <b>DTITUS</b>

# MX150L ASSEMBLY INSTRUCTIONS

3. Repeat Step 2 until all terminals are inserted into the housing. If a terminal is inadvertently assembled into the wrong position, use service tool to remove.
4. If using a circuit plug to seal an unused circuit, apply the same procedure as terminal insertion above. Insert the circuit plug until it clicks twice and a slight pull back on the circuit plug is met with resistance from terminal retention feature.
  - DO NOT continue to push the circuit plug after the second audible click. The circuit plug should rest on the second stop in the connector receptacle housing.
  - In its final position, the dimension between the receptacle housing and the circuit plug is approximately 0.285" (7,24mm) (See Figure 9 & Figure 10).

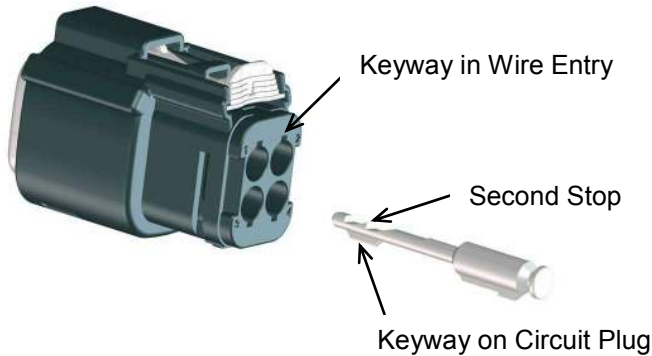

Figure 9: Circuit Plug Orientation

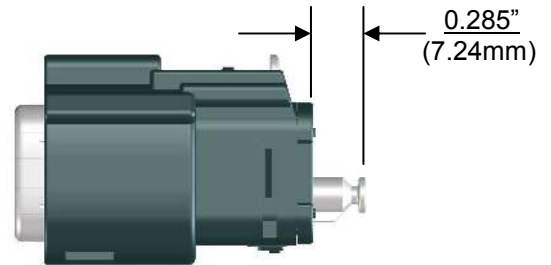

Figure 10: Circuit Plug in Final Position

5. When all terminals and/or circuit plugs are in their proper location, push down on TPA until it clicks into place and is roughly flush or on same level as edge of outer housing (See Figure 11).

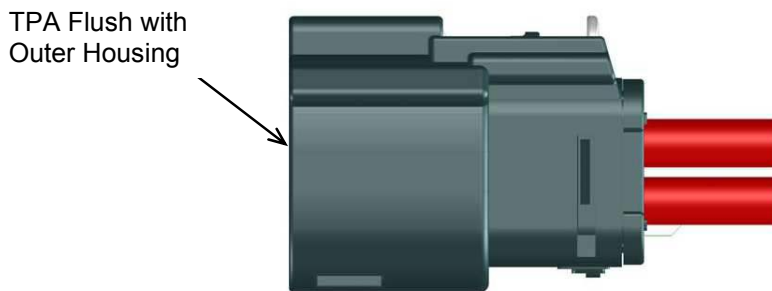

Figure 11: TPA in Locked Position

REVISION: <b>B</b>	ECR/ECN INFORMATION: EC No: <b>IPG2013-0274</b> DATE: <b>2012 / 08 / 22</b>	TITLE: <b>ASSEMBLY INSTRUCTIONS FOR MX150L SEALED CONNECTOR SYSTEM</b>	SHEET No. <b>4 of 5</b>
DOCUMENT NUMBER: <b>AS-19417-001</b>	CREATED / REVISED BY: <b>WLEUNG</b>	CHECKED BY: <b>DTITUS</b>	APPROVED BY: <b>DTITUS</b>

# MX150L ASSEMBLY INSTRUCTIONS

## CONNECTOR POSITION ASSURANCE ACTIVATION

1. After mating the plug and receptacle connectors, push the Connector Position Assurance feature (CPA) on the receptacle forward until it clicks or is as far forward towards mating end of receptacle as possible (See Figure 12). This will prevent accidental depression of latch and un-mating of connectors.

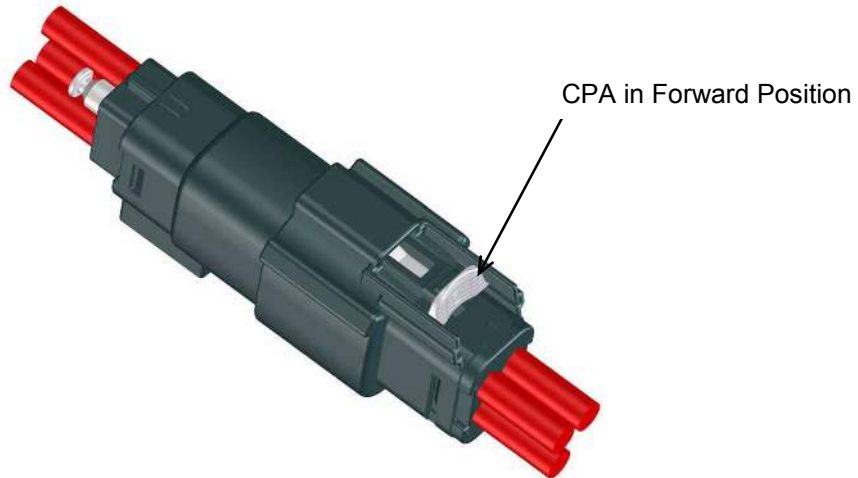

Figure 12: CPA in Locked Position

2. To un-mate connectors, pull CPA towards rear or wire entry end of receptacle. While lightly pushing connectors together, depress latch and then pull the mated connectors apart (See Figure 13).

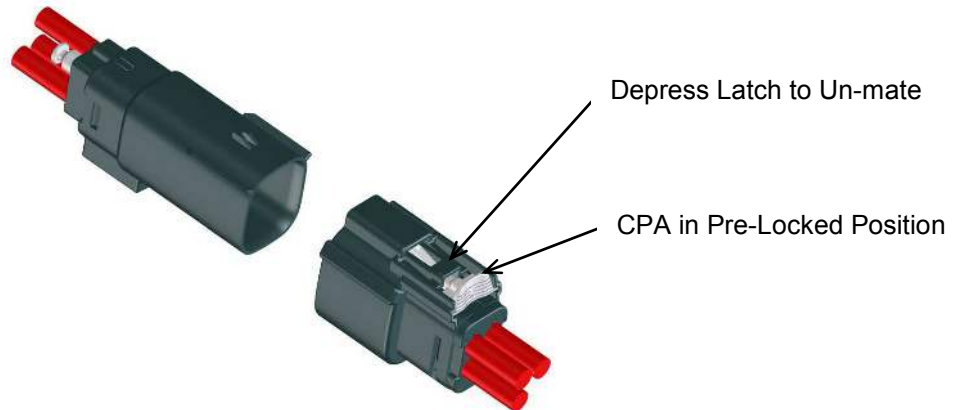

Figure 13: Connectors Un-mated

REVISION: <b>B</b>	ECR/ECN INFORMATION: EC No: <b>IPG2013-0274</b> DATE: <b>2012 / 08 / 22</b>	TITLE: <b>ASSEMBLY INSTRUCTIONS FOR MX150L SEALED CONNECTOR SYSTEM</b>	SHEET No. <b>5 of 5</b>
DOCUMENT NUMBER: <b>AS-19417-001</b>	CREATED / REVISED BY: <b>WLEUNG</b>	CHECKED BY: <b>DTITUS</b>	APPROVED BY: <b>DTITUS</b>