

SENTIR[®]

mat

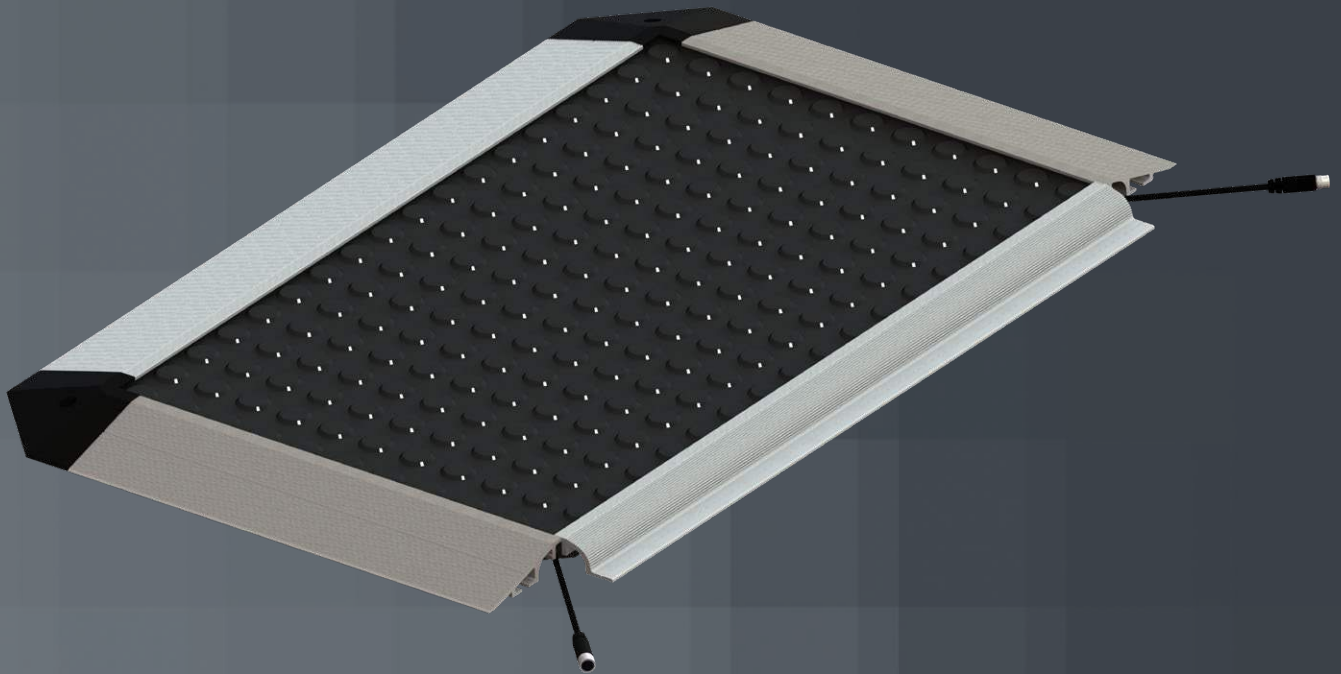

Product Information
U.S. Edition

ASO Safety
Solutions

The principle of the safety-contact-mat

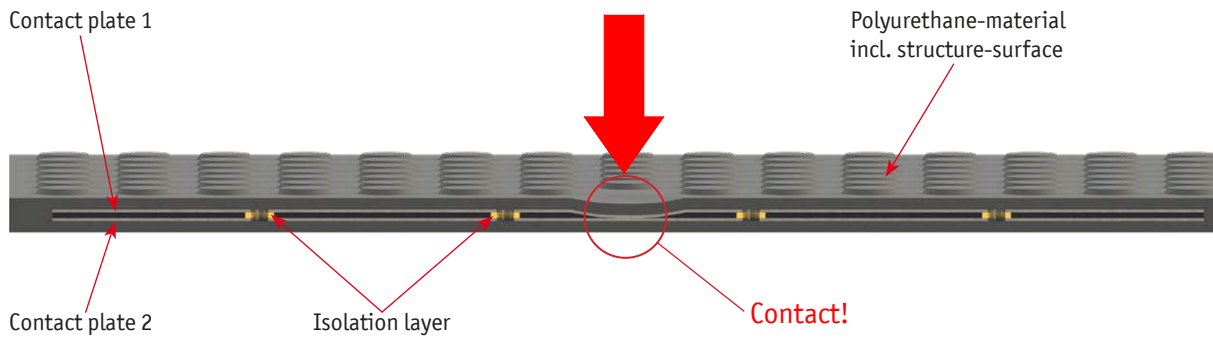

The structure

The basic design principle of the SENTIR mat consists of two conductive plates which are separated by a rasterized insulating layer. These plates are completely molded in a polyurethane material so they are impervious to oil, water and dirt. The surface is slip resistant and provides excellent resistance against oil and grease. Cable exits can be placed customized to your needs. Usually SENTIR mats are provided with corner cable exits and M8 male & female connectors. Either molded or aluminum ramp rails can be used to avoid tripping hazards. Furthermore, in addition to ramp rails, a fixing rail can be provided if necessary.

Signal processing

The SENTIR mat is usually fitted with twin- cables and offers the possibility of connecting several mats in series up to a maximum total area of 10 m² (15500 in²). One end of the cable is connected to a safety relay and the terminal resistance is connected to the other end (set up by manufacturer). The safety relay provides monitoring for the entire circuit, including cabling and mats, by monitoring the terminal resistance. The two plates make contact when stepped on and the resistance is bridged. This immediately causes a signal within the electronics that is then given as a potential free relay output. At the same time, the entire switching circuit is wire fault or manipulation monitored. In case of special requirements, the SENTIR mat can be produced for a 4-wire-monitoring.

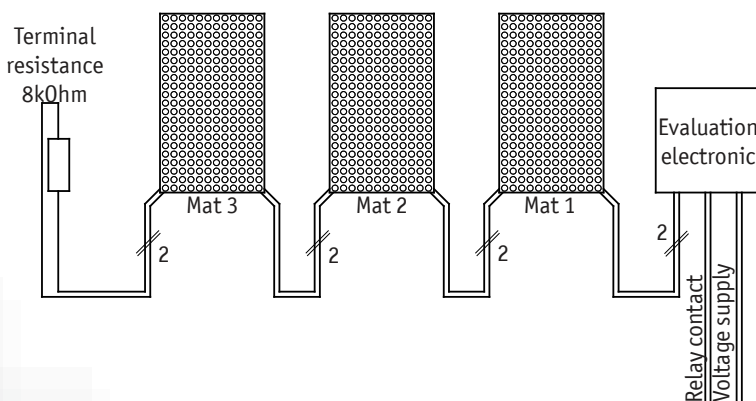

Please pay attention to:



To avoid the risk of crushing, Safety gloves must be worn!

- Up to 10 contact mats wired in series may be connected to one evaluation control unit. The maximum total area can not exceed 10m² (107,64 sq.ft.)!
- The total cable length must not exceed 25m(82').
- The 8.2 kΩ terminal resistance must be connected to the last mat in series when several mats are connected!
- Please inquire separately for mats with recesses or special shapes.

To be done by a person trained or qualified in electrical and mechanical engineering.

Ramp rail

The ramp rail RS 14 provides secure mounting capability for the safety contact mat. The angled design reduces tripping and slipping when mounted to the mat. The integrated channel can be used for clean and safe installation of the connecting cable.

Fixation rail BS 14

The fixation rail BS 14 can be used to attach the safety contact mat in less accessible areas (for example at machines, shut-off positions, walls, etc.). Also the integrated channel can be used for clean and safe installation of the connecting cables.

Fastening sleeve

Enables the safety contact mat to be fixed to the floor without additional space being needed. Different than the fixation rail BS14, a fastening sleeve is implemented into the mat design.

SENTIR mat 14

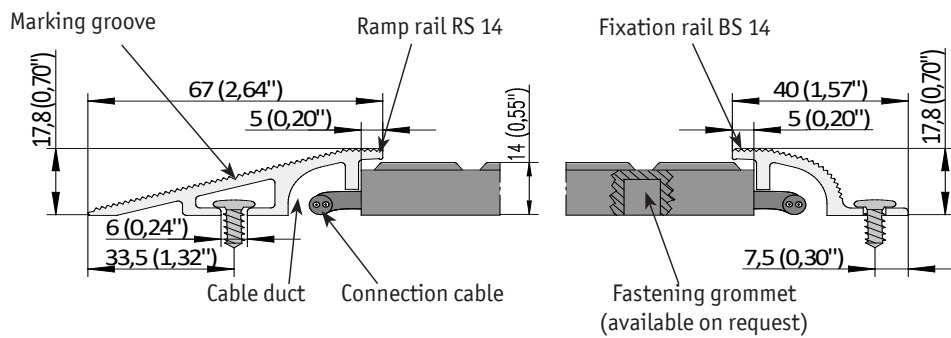

SENTIR mat 14 ARB (SENTIR mat 14 TBV)

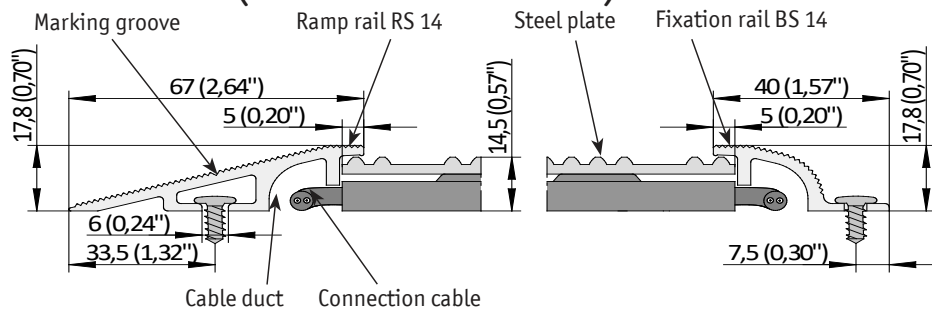

Technical specification for Safety contact mats

	SENTIR mat 14 U/ SENTIR mat 14 T	SENTIR mat 14 ARB
Max. dimensions	2000 mm x 1250 mm (78,74"x49,21")	2000 mm x 1250 mm (78,74"x49,21")
Standard dimensions available from stock	only SENTIR mat 14 U / T 1000 mm x 750 mm (39,37" x 29,53") 1000 mm x 1000 mm (39,37" x 39,37") 1000 mm x 1500 mm (39,37" x 59,06")	
Height	14 mm (0,55") with covering	14 mm (0,55") with covering
Surface	Euro dot	checkered
Weight	U 24,9 Kg/m ² (54,9lb/10,76ft ²); T 26 Kg/m ² (57,32lb/10,76ft ²)	approx. 31,5 kg/m ² (69,45lb/10,76ft ²)
Inactive edge	16 mm (0,63")	30/40 mm (1,18"/1,57")
Switching pressure	Test piece Ø 80 mm (3,15") = approx. 150 N	Test piece Ø 80 mm (3,15") = approx. 150 N
Static load	max. 2000 N over Ø 80 mm (3,15") *	max. 2000 N over Ø 80 mm (3,15") *
Response time	< 25 ms *	< 25 ms *
Switching cycles	min. 1 million *	min. 1 million *
Electrical capacity	24 V 100 mA	24 V 100 mA
Material	PUR black, 78 +/- 5 Shore A	PUR black, 78 +/- 5 Shore A
Protection class	IP 65 (IP 67)	IP 65 (IP 67)
Temperature range	-10°C (+14°F) to +55°C (+131°F)	-20°C (-4°F) to +55°C (+131°F)
Chem. resistance:		Aluminium
Oil	good	good
Petrol	resistant	good
Solvent	sufficient	good
Diluted Acid	resistant	good
Diluted lye	resistant	good
Connection cable	Standard: 2 pcs. - 2 x 0,34 PVC / PU cover black Ø 3,5 mm with M8 male/female plug 120 mm (4,72") Alternative: 1 pc. 4 x 0,25 PVC / PU cover black Ø 4,4 mm with open wires (BN: 1, BU: 3 WH: 2, BK: 4)	
Fire and shock evaluation	UL 508 and CSA C22.2 no. 14	

* tested according to DIN EN ISO 13856-1

Order key

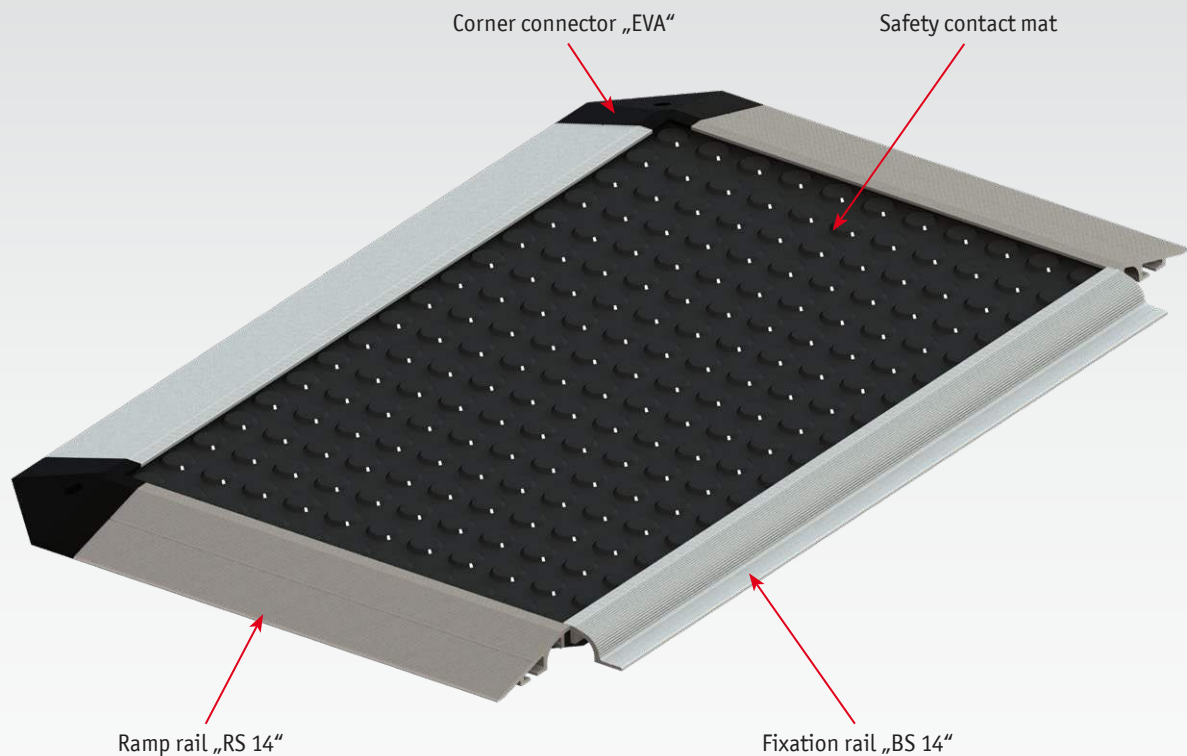

1.	2.	3.	4.	5.	6.
SENTIR mat	-	14	1	T	4.X NP

1. Description

ASO-Safety Contact Mat

2. Height

e.g. 14 mm (0,2")

3. Number of switch zones within one mat

4. Materials ground plate

- U** : One compound mat
- T** : With molded ramp rail
- F** : For ARB- or TBV-cover

5. Cable versions

- 0** : 1x double-lead cable connection
- 1** : 1x cable connection + internal end resistor
- 2** : 2x double-lead cable connection
- 3** : 1x cable connection with external resistor
- 4.0** : 1x M8 connector male and 1x M8 connector female

Alternatives on request

6. Surface

- ARB** : Aluminum cover
- TBV** : Stainless steel cover
- NP** : Dot surface

Technical data of accessories

Applicable to:	Ramp rail RS 14 SENTIR mat 14 ARB / 14 TBV / 14 NP
Articel-No.:	603001
Material:	Aluminum AlMgSi 0,5
Standard length of delivery:	3 m (9,84´)
Weight:	Ca. 788 g (1,74 lb) / serial meter (3,28´)
Accessories:	3 sealing plugs/serial meter

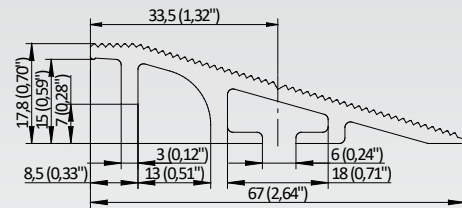

Applicable to:	Fixation rail BS 14 SENTIR mat 14 ARB / 14 TBV / 14 NP
Articel-No.:	603003
Material:	Aluminium AlMgSi 0,5
Standard length of delivery:	3 m (9,84´)
Weight:	Ca. 411 g (0,91 lb) /serial meter (3,28´)

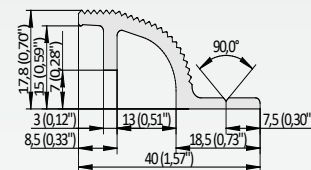

Applicable to:	Corner connector EVA SENTIR mat 14 ARB / 14 TBV / 14 NP
Articel-No.:	603020
Material:	PA 6 30% DV, black
Weight:	ca. 29 g (0,06lb) / pc.

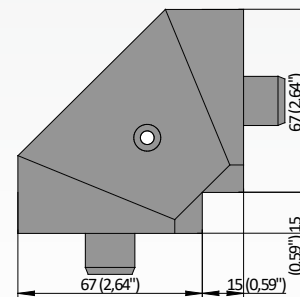

Applicable to:	Aluminum surface SENTIR mat 14 ARB
Articel-No.:	1600028
Material:	Aluminum 2,5 mm (0,10"), max. 2500 x 1400 mm (98,43"x55,12")
Weight:	Ca. 7,6 kg/m ² (1,56 lb/ft ²)

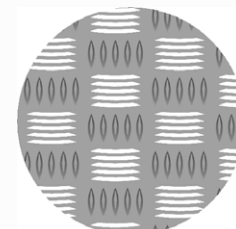

Aluminum checkered plate

Applicable to:	Stainless steel surface SENTIR mat 14 TBV
Articel-No.:	1600016
Material:	Stainless steel 2,5 mm (0,10"), max. 2500 x 1250 mm (98,43"x49,21")
Weight:	Ca. 11,6 kg/m ² (2,38 lb/ft ²)

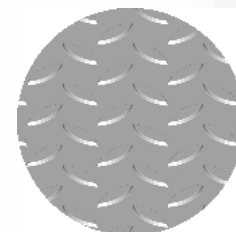

Stainless steel bulb plate

Handling / Storage:



To avoid the risk of crushing, Safety gloves must be worn!

- Do not drag SENTIR mats by their lead wire
- Never store outdoors
- Do not place SENTIR mats leaving overlaps- place bigger SENTIR mats at the bottom
- Bending long SENTIR mats by carrying them flat subjects them to undesirable stress

Installation / Procedures:



To avoid the risk of crushing, Safety gloves must be worn!



Read all instructions first before installing/setting up the Product!

Do not drink any alcohol or take any drugs before or during the setup of the Product and follow the safety instructions carefully.

- Important: All installations, repairs and tests should be performed by a trained, responsible individual.
- Unpack the SENTIR mats carefully keeping them flat and not to pull on the wires. Place the SENTIR mats on the floor in the planned positions with the connecting wires at the outer limits of the detection zone.
- The control unit should be installed as supplied. It must not be modified or subjected to procedures or connections other than those described with the instructions.



MOUNTING INFORMATION

Preparations/set-up:



- Lay out and position the mat correctly. Mats may not be folded or bent. Safety-Contact-Mats may not be manipulated in any way. Cut outs or shortening is not possible.
- The floor or mounting surface for the SENTIR mats has to be flat, smooth, rigid, clean and dry and show no observable distortion under the heaviest load anticipated. Undulations, protrusions, large gaps or other irregularities will increase the sensitivity of the SENTIR mats and may result in intermittent unintended switching off.
- Wiring must be in accordance with the National Electric Code and applicable local codes and ordinances.
- Commissioning should be undertaken by a trained electrical technician experienced in safety installations.
- Ensure that the personnel understand that no additional coverings, boards, plates or planks are to be in the SENTIR mat during operation of the machine.

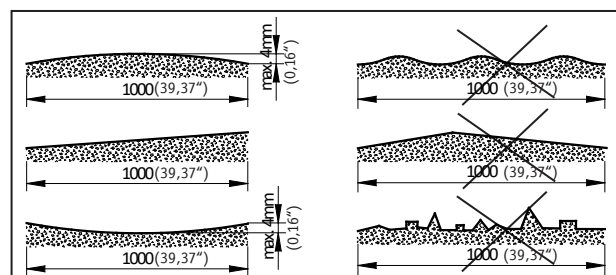
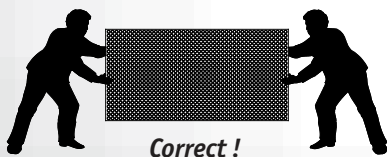

Flatness tolerance for subfloor (according to DIN 18202)

Please note for measurement:

The ramp rail and/or the fixation rail is needed to fix the mat on the floor. Subsequently, the total space required is calculated by adding up the zone to be guarded (nominal dimension of mat) and the width of the ramp rail or fixation rail.

	Ramp rail	additional size	mounting rail	additional size
SENTIR mat 14	RS 14 Aluminum	62 mm (2,44")	BS 14 Aluminum	35 mm (1,38")
SENTIR mat 14 T	molded	30 mm (1,18")	- / -	- / -
SENTIR mat 14 ARB	RS 14 Aluminum	62 mm (2,44")	BS 14 Aluminum	35 mm (1,38")
SENTIR mat 14 TBV	RS 14 Aluminum	62 mm (2,44")	BS 14 Aluminum	35 mm (1,38")

Available space for safeguarding:

Required Safety contact mat:

Example of calculation:

Ordering example:

1200 x 500 mm (47,24" x 19,69")

SENTIR mat 14 with ramp rail **RS 14** and mounting rail **BS 14**

$1200\text{ mm} - 62\text{ mm} - 62\text{ mm} = 1076\text{ mm}$ (47,24" - 2,44" - 2,44" = 42,36")

$500\text{ mm} - 62\text{ mm} - 35\text{ mm} = 403\text{ mm}$ (19,69" - 2,44" - 1,38" = 15,87")

SENTIR mat 14 1000 x 400 mm (19,69"-2,44") with **RS 14** and **BS 14** also with specification for positions of RS 14, BS 14 and cable outlet

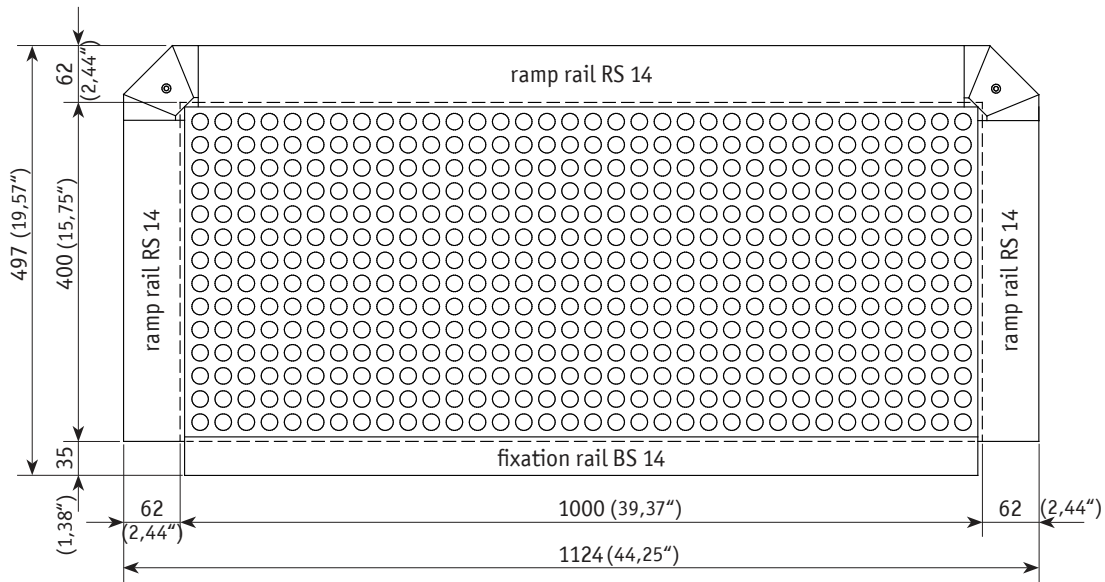

Max. producible size is 2000 mm x 1250 mm. Measures exceeding this size are feasible by combining several SENTIR mat.

If several mats are laid side by side, it has to be done very tightly to the joint.

Afterwards, connect the mats electrically and check the resistance.

Commissioning should be undertaken by a trained electrical technician experienced in safety installations.

The resistance is supposed not to vary more than 500 Ohm from 8,2 kOhm in unactuated condition.

Make sure that the cables are not damaged in a way that could possibly influence its function.

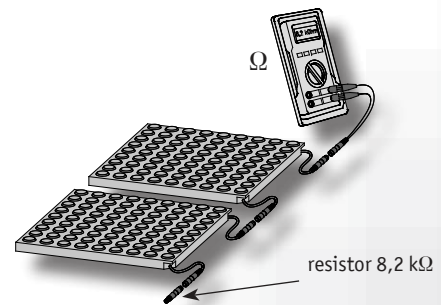

Assembly of SENTIR mat 14



To avoid the risk of crushing, Safety gloves must be worn!
 Installation and electrical work must be performed by authorized electricians.

When using corner connectors, the ramp rail has to be shortened 20mm (0,79") for each corner connector.
 Insert the cable-near corner connector from above to make sure the cable is led through the cable duct (fig. 1). Then attach the ramp rail to the ground with 6mm (0,24") dowels and appropriate screws.
 Adjust the ramp rail laterally to the mat and plug it on the guiding pin (fig. 2). Mark the fastening points (One each 60cm/23,62") on the center line of the ramp rail and pre-drill 10 mm (0,39") for the sealing plugs. Then again attach the ramp rail to the ground with 6 mm (0,24") dowels and appropriate screws and seal the holes with the sealing plugs (fig. 3).
 For additional ramp rails follow the same instructions.

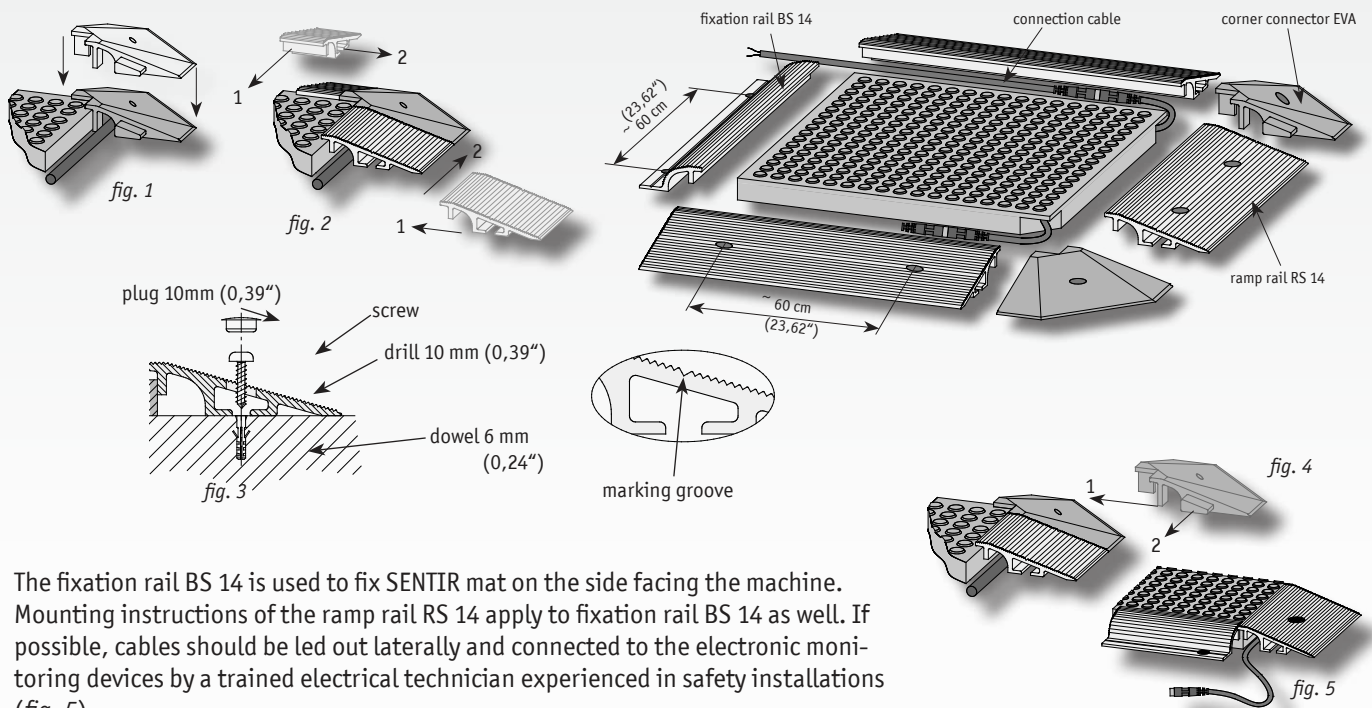

The fixation rail BS 14 is used to fix SENTIR mat on the side facing the machine. Mounting instructions of the ramp rail RS 14 apply to fixation rail BS 14 as well. If possible, cables should be led out laterally and connected to the electronic monitoring devices by a trained electrical technician experienced in safety installations (fig. 5).

SENTIR mat 14 ARB / SENTIR mat 14 TBV

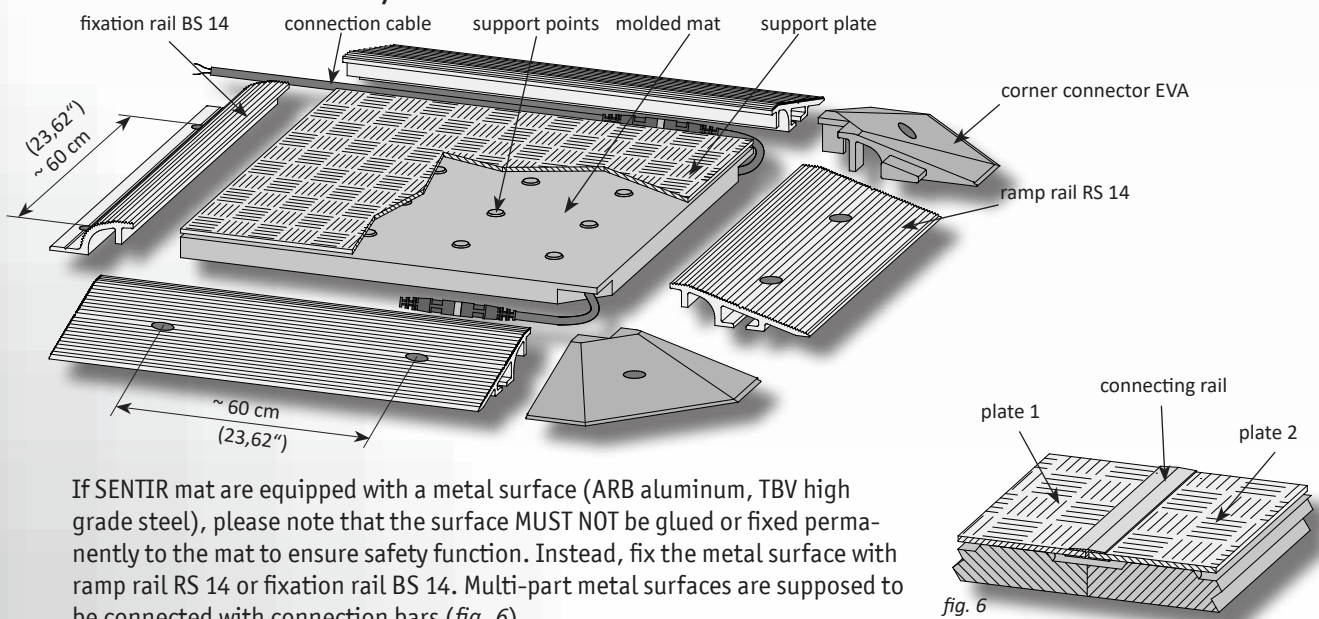

If SENTIR mat are equipped with a metal surface (ARB aluminum, TBV high grade steel), please note that the surface **MUST NOT** be glued or fixed permanently to the mat to ensure safety function. Instead, fix the metal surface with ramp rail RS 14 or fixation rail BS 14. Multi-part metal surfaces are supposed to be connected with connection bars (fig. 6).

Mounting of SENTIR mat 14 T with molded ramp rail

Please note for oversize:

The total space requirement of a SENTIR mat with molded ramp rail results from the space of the area to be safeguarded (nominal dimension of mat) and the width of the ramp rail. The width of the ramp rail RS 14 is 30 mm (1,18") (*fig. 7*).

In order to avoid any clamping or pinching of the cables, cut the cable outlet on required side (*fig. 8*).

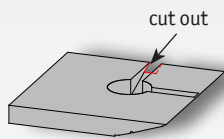

fig. 8

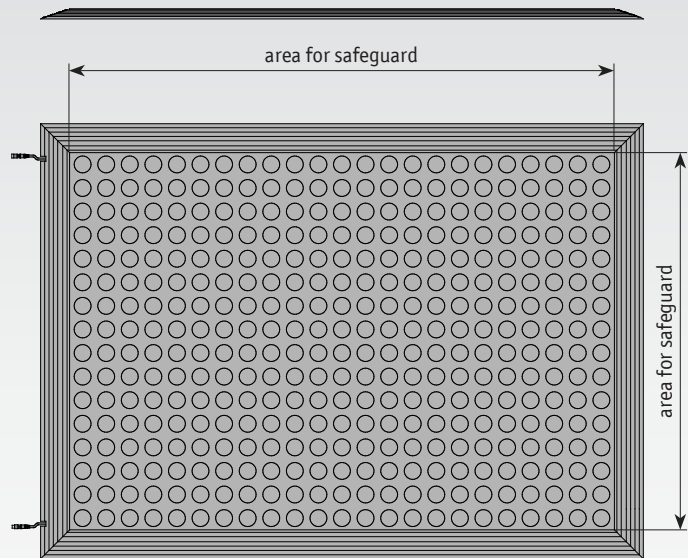

fig. 7

Installation

Adjust the SENTIR mat according to your needs and fix them to the floor with adequate dowels and screws (*fig. 9*).

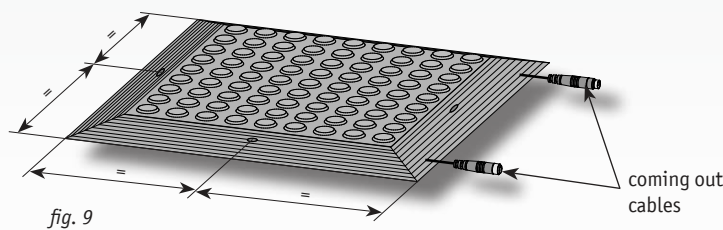
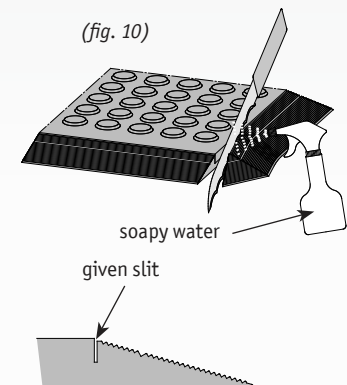

fig. 9



(*fig. 10*)



If several mats are laid side by side, it has to be done very tightly to the joint. Therefore, ramp rails have to be cut off on the sides which are supposed to be sequenced. Spray soapy water over knife and given cutting slit (*fig. 10*). Adjust the SENTIR mats and protect them against displacement (*fig. 11*).

Afterwards, the mats have to be connected electrically and the resistance has to be checked by a trained electrical technician experienced in safety installations.

The resistance is supposed not to vary more than 500 Ohm from 8,2 kOhm in unactuated condition.

Unevenness and/or small inclusions of air which can appear on the back of the mat does not affect the functionality of the SENTIR mat in any way. These kind of visual appearances are caused during the production process and do not constitute a cause for any complaint.

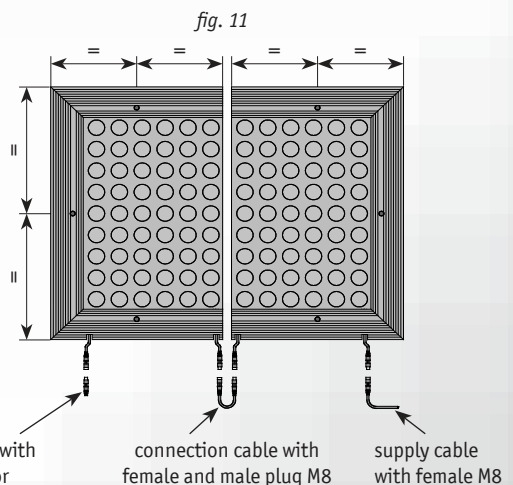

fig. 11

For traffic safety the cable outputs should always be aligned to the machine side!



Read all instructions first before installing/setting up the Product!
Do not drink any alcohol or take any drugs before or during the setup of the Product and follow the safety instructions carefully.

Maintenance:



To avoid the risk of crushing while maintaining, Safety gloves must be worn!

Installation and electrical work must be performed by authorized electricians.

- Weekly check whether fluids have collected around the SENTIR mats, possibly indicating fluids underneath the SENTIR mats as well.
- The SENTIR mats should be regularly swept to prevent potential hazards. If it is necessary to wash or hose down the SENTIR mats to clean or remove grease etc., warm water and detergent may be used.
- Do not use solvents to clean SENTIR mats.

Routine Inspection and tests:

- Recommended weekly.
- Stop the machine, clean the SENTIR mats and allow them to dry off. Inspect the top surface of the SENTIR mat for damage.
- Damage which exposes the metal plate must be dealt with immediately. Check that the trims are not cracked or broken. Damaged parts must be replaced immediately. Otherwise there is a risk of function failure, as well as a risk of injury.
- Test the SENTIR mat operations.
- If the inspections tests performed reveal any problems, do not allow use of the machine until they are rectified. Record the inspection and test in a written log.

Thorough Examination and test:

Recommended twice yearly or after damage. To be done by a person trained or qualified in electrical and mechanical engineering.

- Isolate power source to the machine. Observe electrical safety precautions.
- Disconnect the SENTIR mat from the control unit.
- Inspect the SENTIR mat components thoroughly for mechanical damage.
- Test the SENTIR mat operations.
- If the inspections tests performed reveal any problems, do not allow use of the machine until they are rectified. Record the inspection and test in a written log.

The sequence of examination operations varies at different applications. The trained staff is responsible for the correct sequence of examination operating in terms of safety.

TAMPERING WITH COMPONENT PARTS WILL INVALIDATE WARRANTY.

In the event of problems contact the supplier.

Precautions (General):

Warning: It is the customer's responsibility to determine whether an application is subject to safety distance requirements in order to comply with OSHA and/or other safety standards.

Precautions- Do Not's:

- Do not put holes in active portion of SENTIR mat. Holes or cuts in the SENTIR mats will decrease the life of the SENTIR mat and could cause permanent failure
- Do not attempt to reduce your weight while on the SENTIR mat (ie: don't lean on machine or railings)
- Do not paint the SENTIR mat
- Do not pull on the lead wires

- Do not fold the SENTIR mat. Always transport and store flat
- Do not allow dirt and spills to build up- keep area clean and dry
- Do not run lead wires under the SENTIR mat

In general, the SENTIR mats have good resistance to oils, fuels, solvents, acids diluted and bases diluted.

NOTE: Combinations of chemicals can have unpredictable effects. Testing is recommended in such cases. Small pieces of the material are available if testing is required.

SENTIR mat patterns provide a non-slip surface under most conditions, but should be kept free from large deposits of grease, soaps or gels.

Wear and Damage:

- The SENTIR mat's outer surface can be damaged by impacts from sharp or heavy objects. After every such event the SENTIR mat should be inspected for deformation or puncturing and replaced if necessary.



- The SENTIR mats have been designed and tested to withstand one million activations in any one spot. In use, this number of operations in a single location should not be exceeded. Occasional heavy loads are unlikely to damage the SENTIR mats but they should not be used on traffic through routes.
- SENTIR mats are not suitable for use in explosive atmospheres.

Disclaimer

In no event will the manufacturer be responsible or liable for indirect or consequential damages resulting from the use or application of this equipment.

If applied incorrectly, serious injury or death can occur.

The user must observe the safety instructions in this operating instructions manual, the country-specific installation standards as well as all prevailing safety regulations and accidents prevention rules.

The information contained in this operating instructions manual is provided without liability and is subject to technical modifications.

There are no residual risks, provided that the safety instructions as well as the instructions regarding mounting, commissioning, operation and maintenance are observed.

Exclusion of Liability: The manufacturer shall accept no liability for damages and malfunctions resulting from defective mounting or failure to comply with this operating instructions manual. The manufacturer shall accept no liability for damages resulting from the use of unauthorized spare parts or accessories.

Beyond that, the current version of ASO's General Terms and Conditions shall apply.

1. No safety functions have been evaluated by UL

2. When the device is not supplied by Class 2 source, the input shall be protected by a fuse with a current rating of 100 divided by the supply voltage, not to exceed 5 Amps

EC - Declaration of conformity

EG - Konformitätserklärung (gemäß Anhang II 2006/42/EG)
EC Declaration of conformity (according annex II 2006/42/EC)
Déclaration de conformité CE (selon annexe II 2006/42/CE)



Hiermit erklären wir, dass die nachfolgend bezeichneten Schaltleisten

We hereby declare that the following products of sensing contact edges

Par la présente nous déclarons que les produits suivants de la série barres palpeuses:

SENTIR mat 10 / 10T
SENTIR mat 14 / 14T

SENTIR mat 10 / 10T
SENTIR mat 10 / 14T

SENTIR mat 10 / 10T
SENTIR mat 10 / 14T

zur Kombination mit den Sicherheitsschaltgeräten der Baureihe

for the combination with safety relays of the model range

en combinaison avec les relais de sécurité

ELMON classic 31
ELMON classic/rail 32
ELMON rail 34
ELMON rail 35
ELMON rail 39
ELMON classic/rail 41

ELMON classic 31
ELMON classic/rail 32
ELMON rail 34
ELMON rail 35
ELMON rail 39
ELMON classic/rail 41

ELMON classic 31
ELMON classic/rail 32
ELMON rail 34
ELMON rail 35
ELMON rail 39
ELMON classic/rail 41

aufgrund ihrer Konzipierung und Bauart sowie in der von uns in Verkehr gebrachten Ausführung, den einschlägigen grundlegenden Sicherheits- und Gesundheitsanforderungen der nachfolgenden EG-Richtlinien und Normen entspricht:

satisfies the relevant essential health and safety requirements of the EC directives and standards listed below on account of its design and construction, as does the version brought to market by us:

de par sa conception et sa construction, ainsi que dans les modèles mis en circulation par nos soins, répondent aux exigences de base pour la sécurité et la santé des directives et normes CE suivantes :

2006/42/EG
EN ISO 13856-1:2013
EN ISO 13849-1:2008

2006/42/EC
EN ISO 13856-1:2013
EN ISO 13849-1:2008

2006/42/CE
EN ISO 13856-1:2013
EN ISO 13849-1:2008

EG-Baumusterprüfung
 Notified Body 0044
 TÜV Nord Cert GmbH
 Langemarckstraße 20
 D-45141 Essen
 Nr. 44 205 11 384662 002

EC type-examination
 Notified Body 0044
 TÜV Nord Cert GmbH
 Langemarckstraße 20
 D-45141 Essen
 No. 44 205 11 384662 002

Examen CE de type
 Notified Body 0044
 TÜV Nord Cert GmbH
 Langemarckstraße 20
 D-45141 Essen
 N° 44 44 205 11 384662 002

Diese Konformitätserklärung entbindet den Konstrukteur/ Hersteller der Maschine nicht von seiner Pflicht, die Konformität der gesamten Maschine, an der dieses Produkt angebracht wird, entsprechend der EG-Maschinenrichtlinie sicherzustellen.

This declaration of conformity does not relieve the designer / manufacturer of the machine from his obligation to ensure that the conformity of the entire machine to which this product is attached satisfies the corresponding EC directive.

Cette déclaration de conformité ne délie pas le constructeur / fabricant de la machine de son obligation d'assurer la conformité de l'ensemble de la machine à laquelle ce produit est apposé selon la directive CE.

Hersteller und Dokumentationsbevollmächtigter

Manufacturer and attorney of documents

Fabricant et agent de documentation

ASO GmbH
 Hansastr. 52
 D-59557 Lippstadt
 Lippstadt, 08.05.2014

 H. Friedrich
 - Geschäftsführer - CEO - Gérant -



EC - Declaration of conformity

EG - Konformitätserklärung (gemäß Anhang II 2006/42/EG)
EC Declaration of conformity (according annex II 2006/42/EC)
Déclaration de conformité CE (selon annexe II 2006/42/CE)



Hiermit erklären wir, dass die nachfolgend bezeichneten Schaltleisten

We hereby declare that the following products of sensing contact edges

Par la présente nous déclarons que les produits suivants de la série barres palpeuses:

SENTIR mat 14 ARB
SENTIR mat 14 TBV

SENTIR mat 14 ARB
SENTIR mat 14 TBV

SENTIR mat 14 ARB
SENTIR mat 14 TBV

zur Kombination mit den Sicherheitsschaltgeräten der Baureihe

for the combination with safety relays of the model range

en combinaison avec les relais de sécurité

ELMON classic 31
ELMON classic/rail 32
ELMON rail 34
ELMON rail 35
ELMON rail 39
ELMON classic/rail 41

ELMON classic 31
ELMON classic/rail 32
ELMON rail 34
ELMON rail 35
ELMON rail 39
ELMON classic/rail 41

ELMON classic 31
ELMON classic/rail 32
ELMON rail 34
ELMON rail 35
ELMON rail 39
ELMON classic/rail 41

aufgrund ihrer Konzipierung und Bauart sowie in der von uns in Verkehr gebrachten Ausführung, den einschlägigen grundlegenden Sicherheits- und Gesundheitsanforderungen der nachfolgenden EG-Richtlinien und Normen entspricht:

satisfies the relevant essential health and safety requirements of the EC directives and standards listed below on account of its design and construction, as does the version brought to market by us:

de par sa conception et sa construction, ainsi que dans les modèles mis en circulation par nos soins, répondent aux exigences de base pour la sécurité et la santé des directives et normes CE suivantes :

2006/42/EG
EN ISO 13856-1:2013
EN ISO 13849-1:2008

2006/42/EC
EN ISO 13856-1:2013
EN ISO 13849-1:2008

2006/42/CE
EN ISO 13856-1:2013
EN ISO 13849-1:2008

EG-Baumusterprüfung
 Notified Body 0044
 TÜV Nord Cert GmbH
 Langemarckstraße 20
 D-45141 Essen
 Nr. 44 205 11 384662 001

EC type-examination
 Notified Body 0044
 TÜV Nord Cert GmbH
 Langemarckstraße 20
 D-45141 Essen
 No. 44 205 11 384662 001

Examen CE de type
 Notified Body 0044
 TÜV Nord Cert GmbH
 Langemarckstraße 20
 D-45141 Essen
 N° 44 44 205 11 384662 001

Diese Konformitätserklärung entbindet den Konstrukteur/ Hersteller der Maschine nicht von seiner Pflicht, die Konformität der gesamten Maschine, an der dieses Produkt angebracht wird, entsprechend der EG-Maschinenrichtlinie sicherzustellen.

This declaration of conformity does not relieve the designer / manufacturer of the machine from his obligation to ensure that the conformity of the entire machine to which this product is attached satisfies the corresponding EC directive.

Cette déclaration de conformité ne délie pas le constructeur / fabricant de la machine de son obligation d'assurer la conformité de l'ensemble de la machine à laquelle ce produit est apposé selon la directive CE.

Hersteller und Dokumentationsbevollmächtigter

Manufacturer and attorney of documents

Fabricant et agent de documentation

ASO GmbH
 Hansastr. 52
 D-59557 Lippstadt
 Lippstadt, 13.03.2015



Helmut Friedrich
 - Geschäftsführer - CEO - Gérant -



Headquarter Europe

ASO GmbH
Hansastraße 52
59557 Lippstadt

Tel +49 2941 9793-0
Fax +49 2941 9793-299
www.asosafety.de
sales-eu@asosafety.com

Headquarter USA

ASO Safety Solutions Inc.
300 Roundhill Drive, Unit 6
Rockaway. NJ 07866

Phone +1 973 5869600
Fax +1 973 5861590
www.asosafety.com
sales-us@asosafety.com

Headquarter Asia Pacific

ASO Safety Solutions Nanjing Co. Ltd.
Jinma Lu 3 Maqun Scientific Park
210049 Nanjing

Phone +86 25 856 73990
www.asosafety.cn
sales-cn@asosafety.com



DOC0000178 Technical data Rev 15
as of 16.06.2021
Technical changes reserved.