

POSITIONS/ CONTACTS	A		B		C	
	INCH	MM	INCH	MM	INCH	MM
02/04	0.079	2.00	0.157	4.00		
03/06	0.157	4.00	0.236	6.00	0.079	2.00
04/08	0.236	6.00	0.315	8.00	0.157	4.00
05/10	0.315	8.00	0.394	10.00	0.236	6.00
06/12	0.394	10.00	0.472	12.00	0.315	8.00
07/14	0.472	12.00	0.551	14.00	0.394	10.00
08/16	0.551	14.00	0.630	16.00	0.472	12.00
09/18	0.630	16.00	0.709	18.00	0.551	14.00
10/20	0.709	18.00	0.787	20.00	0.630	16.00
11/22	0.787	20.00	0.866	22.00	0.709	18.00
12/24	0.866	22.00	0.945	24.00	0.787	20.00
13/26	0.945	24.00	1.024	26.00	0.866	22.00
14/28	1.024	26.00	1.102	28.00	0.945	24.00
15/30	1.102	28.00	1.181	30.00	1.024	26.00
16/32	1.181	30.00	1.260	32.00	1.102	28.00
17/34	1.260	32.00	1.339	34.00	1.181	30.00
18/36	1.339	34.00	1.417	36.00	1.260	32.00
19/38	1.417	36.00	1.496	38.00	1.339	34.00
20/40	1.496	38.00	1.575	40.00	1.417	36.00
21/42	1.575	40.00	1.654	42.00	1.496	38.00
22/44	1.654	42.00	1.732	44.00	1.575	40.00
23/46	1.732	44.00	1.811	46.00	1.654	42.00
24/48	1.811	46.00	1.890	48.00	1.732	44.00
25/50	1.890	48.00	1.969	50.00	1.811	46.00
26/52	1.969	50.00	2.047	52.00	1.890	48.00
27/54	2.047	52.00	2.126	54.00	1.969	50.00
28/56	2.126	54.00	2.205	56.00	2.047	52.00
29/58	2.205	56.00	2.283	58.00	2.126	54.00
30/60	2.283	58.00	2.362	60.00	2.205	56.00
31/62	2.362	60.00	2.441	62.00	2.283	58.00
32/64	2.441	62.00	2.520	64.00	2.362	60.00
33/66	2.520	64.00	2.598	66.00	2.441	62.00
34/68	2.598	66.00	2.677	68.00	2.520	64.00
35/70	2.677	68.00	2.756	70.00	2.598	66.00
36/72	2.756	70.00	2.835	72.00	2.677	68.00
37/74	2.835	72.00	2.913	74.00	2.756	70.00
38/76	2.913	74.00	2.992	76.00	2.835	72.00
39/78	2.992	76.00	3.071	78.00	2.913	74.00
40/80	3.071	78.00	3.150	80.00	2.992	76.00

PART NUMBER CODING

xRPNxx2MAMP-M81RC

NUMBER OF POSITIONS

(CONTACTS PER ROW, 02 THRU 40)

INSULATOR MATERIAL

N=NYLON 6T,

OPERATING TEMPERATURE: -40° C TO +105° C

PROCESSING TEMP.: WAVE/MANUAL SOLDERING ONLY

L=LCP,

OPERATING TEMPERATURE: -40° C TO +125° C

PROCESSING TEMP.: 260° C MAX FOR 10 SECONDS

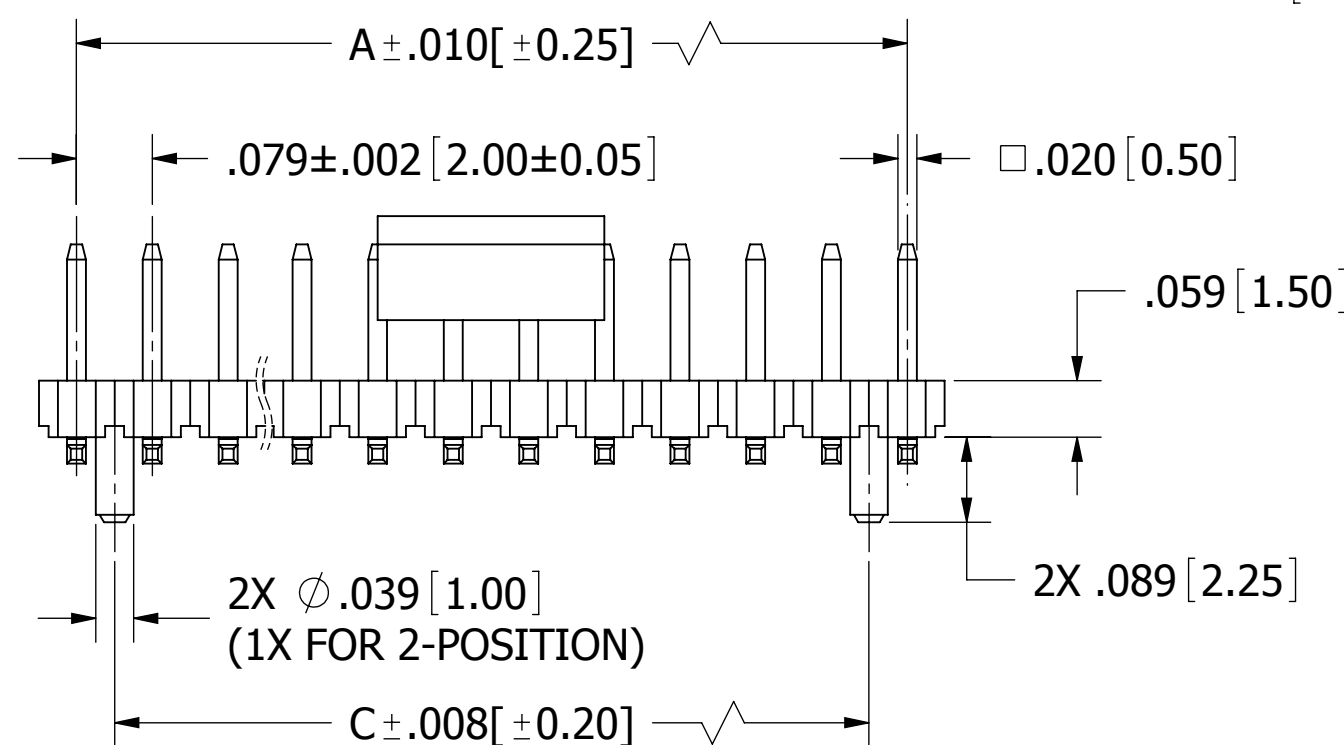
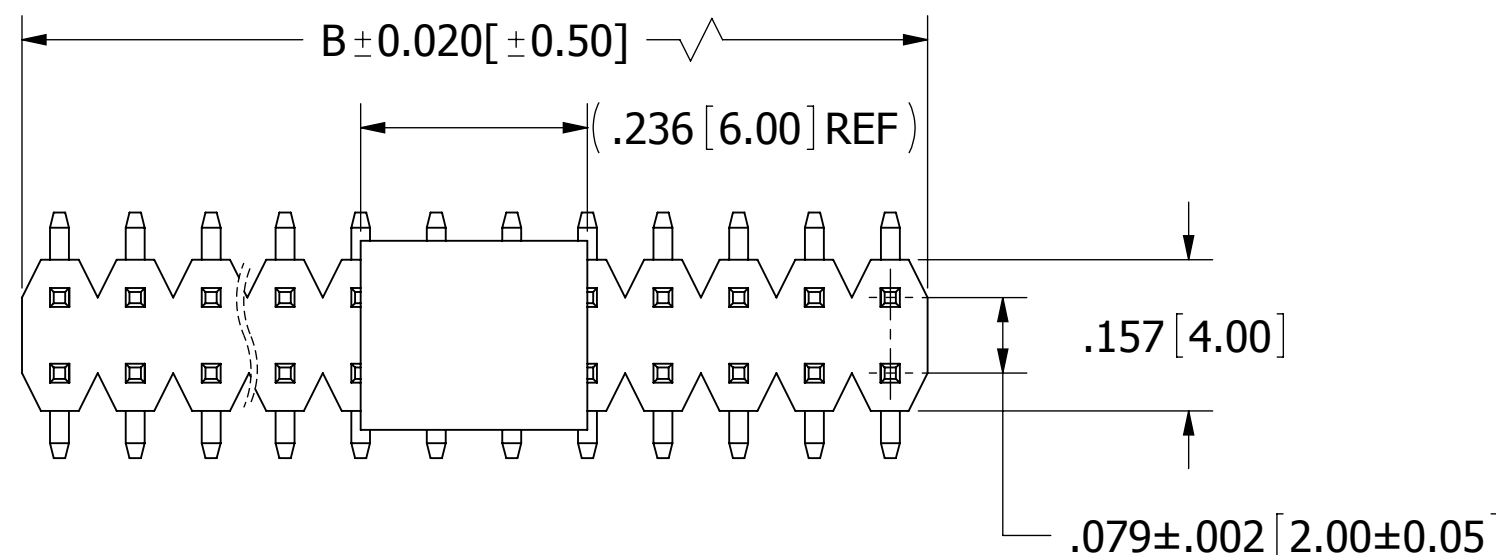

02-20, 0.20mm MAX.
21-30, 0.30mm MAX.
31-40, 0.40mm MAX.

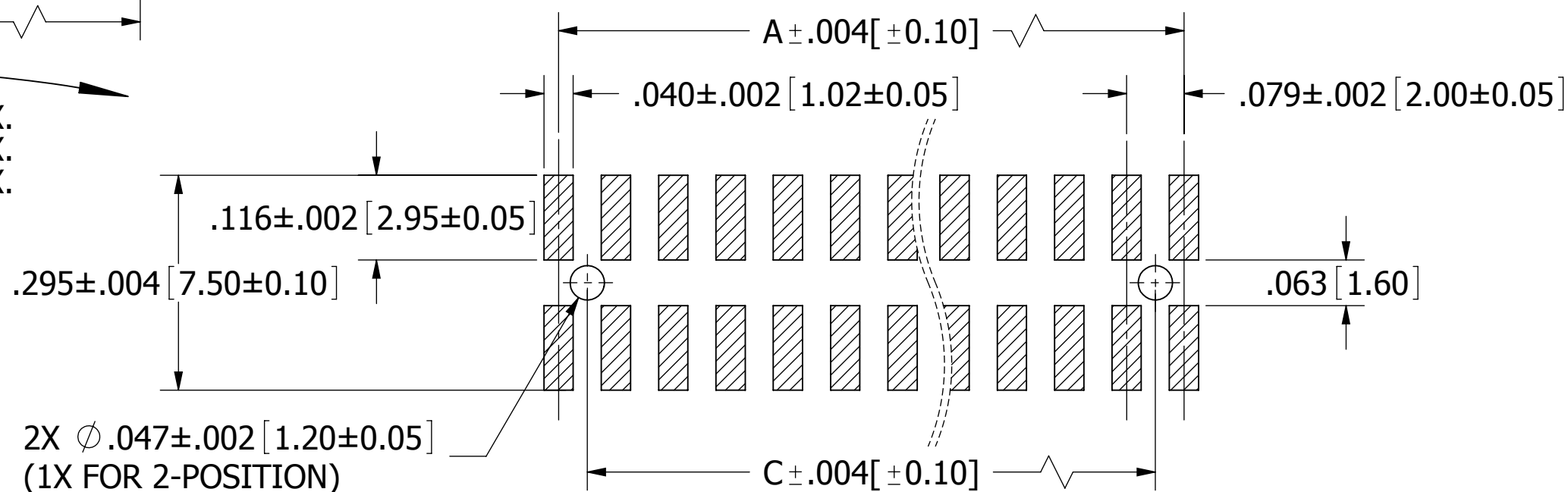

RECOMMENDED PCB LAYOUT

REVISIONS				
REV.	ECO. NO	DESCRIPTION	DATE	BY
B	2213	ADD POSITION NO OPTIONS, UPDATE ALL VIEW AND TAPE & REEL	12/15/2010	LH
C	2828	ADD 'LCP' MATERIAL OPTION, UPDATE PROCESSING TEMPERATURE FOR NYLON 6T MATERIAL, UPDATE OVERALL LENGTH TOL TO 0.50mm (WAS 0.35mm), UPDATE CURRENT RATING TO 2 AMPS (WAS 1 AMP)	04/09/2015	LH

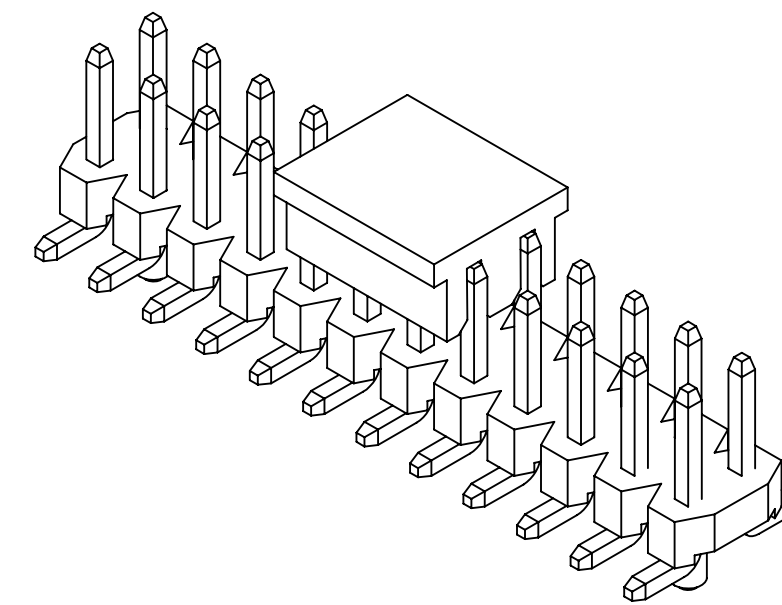

NOTES:

- INSULATOR MATERIAL: SEE PART NUMBER CODING, UL 94V-0, COLOR: BLACK.
- CONTACT MATERIAL: BRASS.
- CONTACT PLATING: .000030"-.000050" MIN NICKEL UNDERPLATE, GOLD FLASH OVERALL.
- CURRENT RATING: 2 AMPS
- VOLTAGE RATING: 150 V AC/DC.
- INSULATOR RESISTANCE: 5000 MEGOHMS MIN.
- CONTACT RESISTANCE: 20 MILLIOHMS MAX.
- DIELECTRIC WITHSTANDING: 500 VAC.
- OPERATING TEMPERATURE: SEE PART NUMBER CODING.
- MODIFICATION: WITH PLASTIC PICK & PLACE CAP IN TAPE AND REEL.

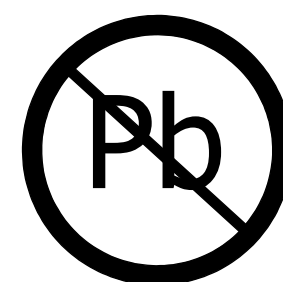

RoHS COMPLIANT

UNLESS OTHERWISE SPECIFIED: DIMENSIONS ARE IN INCHES [MM]	DRAWN	DATE	NAME	
		11/09/2009	LH	
TOLERANCES:	<small>THE INFORMATION HEREIN CONTAINS PROPRIETARY INFORMATION OF SULLINS ELECTRONICS AND IS NOT TO BE REPRODUCED, USED OR DISCLOSED TO OTHERS FOR ANY PURPOSE EXCEPT AS SPECIFICALLY AUTHORIZED IN WRITING BY AN OFFICER OF SULLINS ELECTRONICS.</small>			
ANGULAR: ± 1°	TITLE HEADER, MALE 2.0mm CC, 2 ROWS SP, T&R			
DECIMALS .X = ± .012 [.30] .XX = ± .008 [.20] .XXX = ± .006 [.15]	PART NUMBER xRPNxx2MAMP-M81RC			
	SIZE	CAGE CODE	DWG. NO.	REV
	C	54453	11282	C
	SCALE: 5:1	SHEET 1 OF 2		

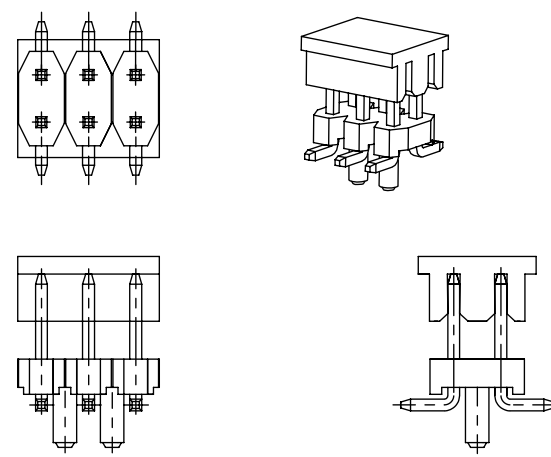

**T&R FOR P/N: xRPNxx2MAMP-M81RC
 (03-POSITION AS SHOWN)
 (SEE T&R DIM TABLE AND NOTE 1)

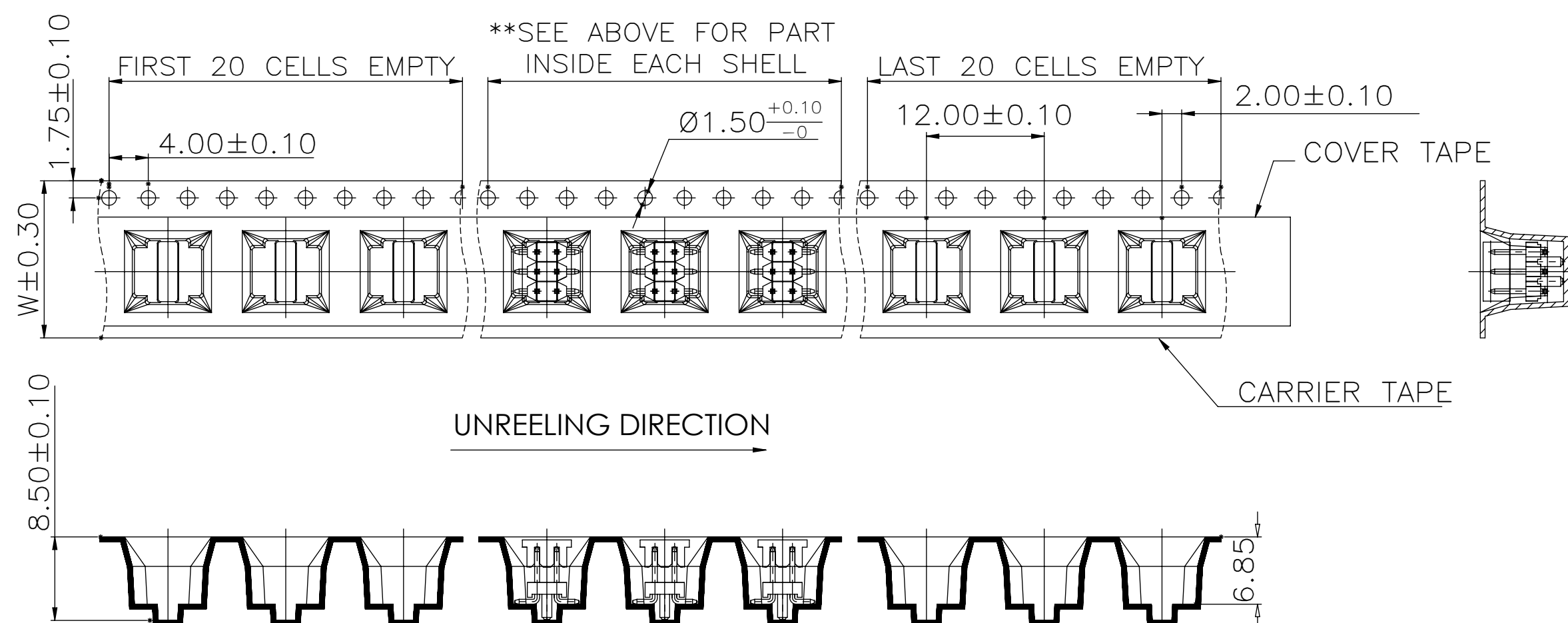

DIMENSION UNIT: mm

T & R DIMENSION TABLE		
POSITIONS/ CONTACTS	W	A
02/04 - 03/06	16	21
04/08 - 06/12	24	29
07/14 - 09/18	32	37
10/20 - 15/30	44	49
16/32 - 21/42	56	61
22/44 - 28/56	72	77
29/58 - 40/80	88	93

NOTE 1: WHEN THE CARRIER TAPE WIDTH IS EQUAL OR SMALLER THAN 24mm,
 Ø 1.5mm CARRIER HOLES ARE LOCATED ON SINGLE SIDE OF CARRIER TAPE.

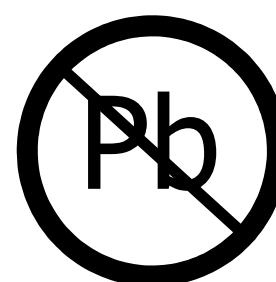
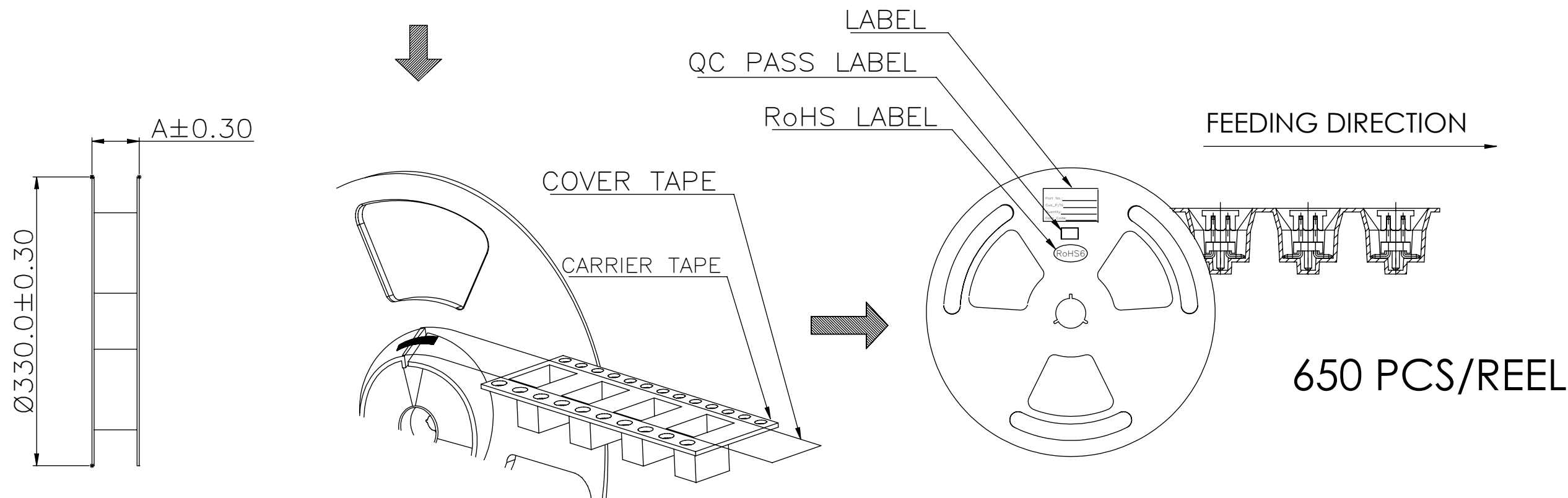

RoHS COMPLIANT

UNLESS OTHERWISE SPECIFIED:
 DIMENSIONS ARE IN INCHES [MM]

TOLERANCES:
 ANGULAR: ± 1°
 DECIMALS
 .X = ± .012 [.3]
 .XX = ± .008 [.20]
 .XXX = ± .0060 [.15]

DRAWN	DATE	NAME
LH	11/9/2009	LH

THE INFORMATION HEREIN CONTAINS PROPRIETARY INFORMATION OF SULLINS ELECTRONICS AND IS NOT TO BE REPRODUCED, USED OR DISCLOSED TO OTHERS FOR ANY PURPOSE EXCEPT AS SPECIFICALLY AUTHORIZED IN WRITING BY AN OFFICER OF SULLINS ELECTRONICS.

DESCRIPTION HEADER, MALE 2.0mm CC, 2 ROWS SP, T&R	
PART NUMBER xRPNxx2MAMP-M81RC	
SIZE C	DWG. NO. 11282
SCALE: 2:1	
SHEET 2 OF 2	