

# Thermofit Molded Parts Specification Control Drawing

Part Number : 222B012 thru 063  
Description : Boot, 90°, With Lip

## NOTES

- All dimensions are in  $\frac{\text{inches}}{\text{[millimeters]}}$
- Dimensions appearing in table are as follows:
  - a - As Supplied
  - b - After Unrestricted Recovery
- Coating is optional. As supplied dimensions appearing in table are for uncoated parts. When coating is added, entry diameters will be reduced by .06 max.
- Molding port is optional. When -00 modification number is specified molding port will be located as shown.

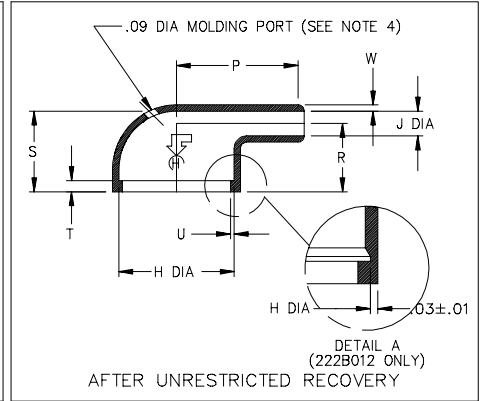
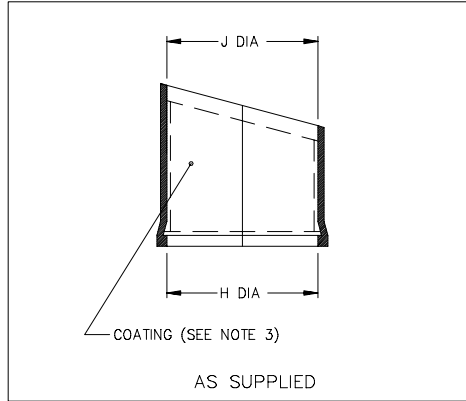

PART NUMBER	H		J		±10% a	±10% b	±10% a	±10% b	±10% a	±10% b	±10% a	±10% b
	Min	Max	Min	Max								
222B012	.93 [23,6]	.69 [17,5]	.93 [23,6]	.25 [6,3]	.78 [19,8]	.57 [14,5]	.50 [12,7]	.09 [2,28]	.03 [0,76]	.05 [1,27]		
222B032	1.18 [29,9]	.88 [22,3]	1.18 [29,9]	.29 [7,3]	.87 [22,1]	.64 [16,2]	.60 [15,2]	.09 [2,28]	.03 [0,76]	.05 [1,27]		
222B042	1.22 [30,9]	.93 [23,6]	1.22 [30,9]	.40 [10,1]	1.03 [26,1]	.65 [16,5]	.55 [13,9]	.09 [2,28]	.03 [0,76]	.05 [1,27]		
222B052	1.32 [33,5]	1.00 [25,4]	1.32 [33,5]	.38 [9,6]	1.03 [26,1]	.69 [17,5]	.60 [15,2]	.09 [2,28]	.03 [0,76]	.05 [1,27]		
222B063	1.44 [36,5]	1.13 [28,7]	1.44 [36,5]	.44 [11,1]	1.14 [28,9]	.76 [19,3]	.63 [16,0]	.09 [2,28]	.03 [0,76]	.05 [1,27]		

**Raychem**

RAYCHEM CORPORATION  
300 CONSTITUTION DRIVE  
MENLO PARK, CALIFORNIA 94025

Revision : B  
Date : 3/31/94

Part Number : 222B012 thru 063  
Description : Boot, 90°, With Lip

# Thermofit Molded Parts Specification Control Drawing

Part Number : 222B012 thru 063  
Description : Boot, 90°, With Lip

MATERIAL DASH NO.	MATERIAL DESCRIPTION	RT SPEC	COATING SLASH NO.	COATING S NO.	COATING DESCRIPTION
-3	Polyolefin, Semi-rigid	RT-301	/42	S-1017	Adhesive
-4	Polyolefin, Flexible	RT-1304			
-25	Elastomer, Fluid Resistant	RT-1325			

## ORDERING INFORMATION

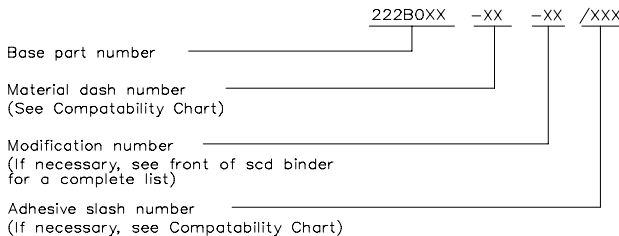

THIS DRAWING IS SUBJECT TO CHANGE WITHOUT NOTICE; CONSULT YOUR NEAREST FIELD REPRESENTATIVE FOR CURRENT REVISION

If this document is printed it becomes uncontrolled.  
Check for the latest revision.

**Raychem**

RAYCHEM CORPORATION  
300 CONSTITUTION DRIVE  
MENLO PARK, CALIFORNIA 94025

Revision : B  
Date : 3/31/94

Part Number : 222B012 thru 063  
Description : Boot, 90°, With Lip

CAD FILE MP94121