



HDMI VIP Input Bridge Board

Evaluation Board User Guide

FPGA-EB-02008-1.1

July 2019

Disclaimers

Lattice makes no warranty, representation, or guarantee regarding the accuracy of information contained in this document or the suitability of its products for any particular purpose. All information herein is provided AS IS and with all faults, and all risk associated with such information is entirely with Buyer. Buyer shall not rely on any data and performance specifications or parameters provided herein. Products sold by Lattice have been subject to limited testing and it is the Buyer's responsibility to independently determine the suitability of any products and to test and verify the same. No Lattice products should be used in conjunction with mission- or safety-critical or any other application in which the failure of Lattice's product could create a situation where personal injury, death, severe property or environmental damage may occur. The information provided in this document is proprietary to Lattice Semiconductor, and Lattice reserves the right to make any changes to the information in this document or to any products at any time without notice.

Contents

Acronyms in This Document	4
1. Introduction	5
1.1. Features	5
1.2. Further Information	6
2. Functional Description	7
2.1. Switches	7
2.2. HDMI Interface	7
3. High-Speed Headers	8
4. Power Supply	10
5. Status Indicators and Test Points	11
6. Ordering Information	12
References	13
Technical Support Assistance	13
Appendix A. HDMI VIP Input Bridge Board Schematics	14
Appendix B. HDMI VIP Input Bridge Board Bill of Materials	18
Revision History	20

Figures

Figure 1.1. Top Side of HDMI VIP Input Bridge Board	5
Figure 1.2. Bottom Side of HDMI VIP Input Bridge Board	6
Figure 2.1 Functional Block Diagram	7
Figure 4.1. Power Supply	10
Figure A.1. Block Diagram	14
Figure A.2. Si1127A HDMI and GPIO Interface	15
Figure A.3. Power Decoupling	16
Figure A.4. Si1127A Power Decoupling	17

Tables

Table 2.1 Si1127A 7-bit I ² C Address	7
Table 3.1 Connector J1	8
Table 3.2 Connector J2	9
Table 5.1 User LEDs	11
Table 5.2 Status LEDs	11
Table 5.3 Test Points	11
Table 6.1 Reference Part Number	12

Acronyms in This Document

A list of acronyms used in this document.

Acronym	Definition
DVI	Digital Visual Interface
GPIO	General Purpose Input/Output
HDCP	High-Definition Content Protection
HDMI	High Definition Multimedia Interface
I ² C	Inter-Integrated Circuit
LDO	Low Dropout
TMDS	Transition-Minimized Differential Signaling
VIP	Video Interface Platform

1. Introduction

This document describes the Lattice Semiconductor HDMI[®] VIP Input Bridge Board. This board is designed to work with the Lattice Video Interface Platform board interconnect system. The key component of this board is the Lattice Semiconductor SiI1127A HDMI Deep Color Receiver.

The contents of this user guide include descriptions of board components, schematics, and bill of materials.

1.1. Features

Key features of the HDMI VIP input bridge board include:

- SiI1127A HDMI Deep Color Receiver
 - Supports Deep Color video resolution up to 12-bit, 1080p at 60 Hz
 - Video Input:
 - Two HDMI/DVI-compatible ports
 - The TMDS™ core runs at 25 MHz – 225 MHz
 - Dynamic cable equalization automatically detects the equalization required for the incoming signal
 - Video Output:
 - xvYCC to extended RGB
 - 36-bit RGB/YCbCr 4:4:4
 - 16/20/24-bit YCbCr 4:2:2
 - 8/10/12-bit YCbCr 4:2:2 (ITU BT.656)
 - No HDCP support
- Two Single-Link 19-pin HDMI Type-A connectors
- Two 60 pin Rugged High-Speed Headers

Figure 1.1 shows the top view of the HDMI VIP input bridge board and its key components. Figure 1.2 on page 6 shows the bottom view of the board.

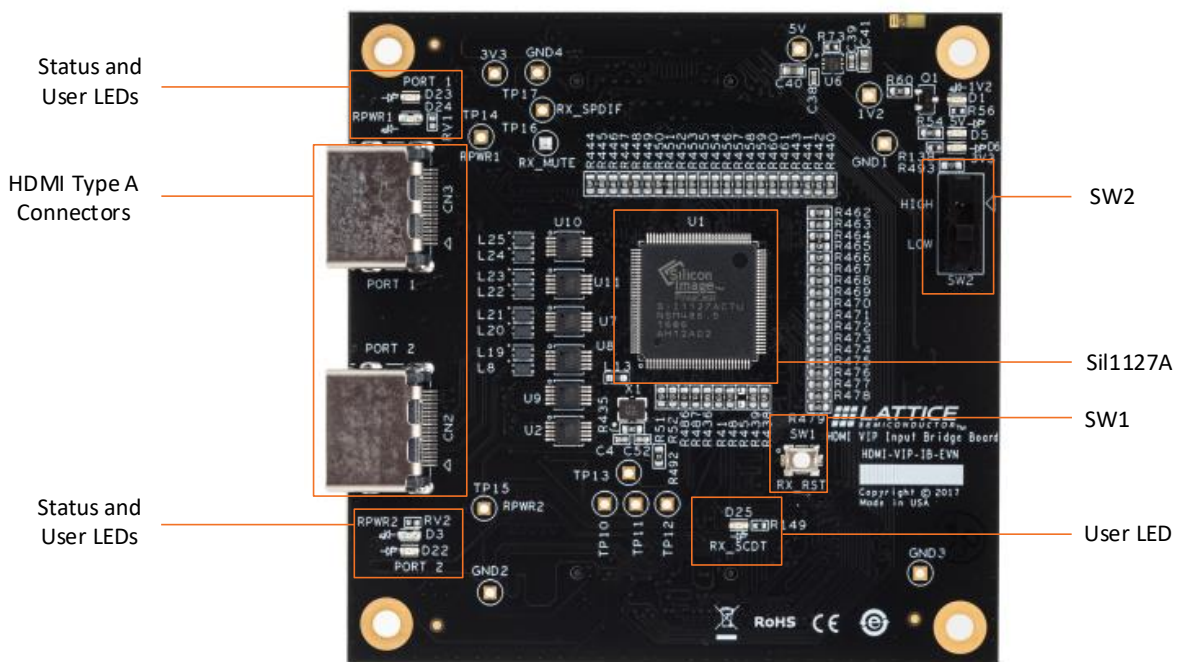

Figure 1.1. Top Side of HDMI VIP Input Bridge Board

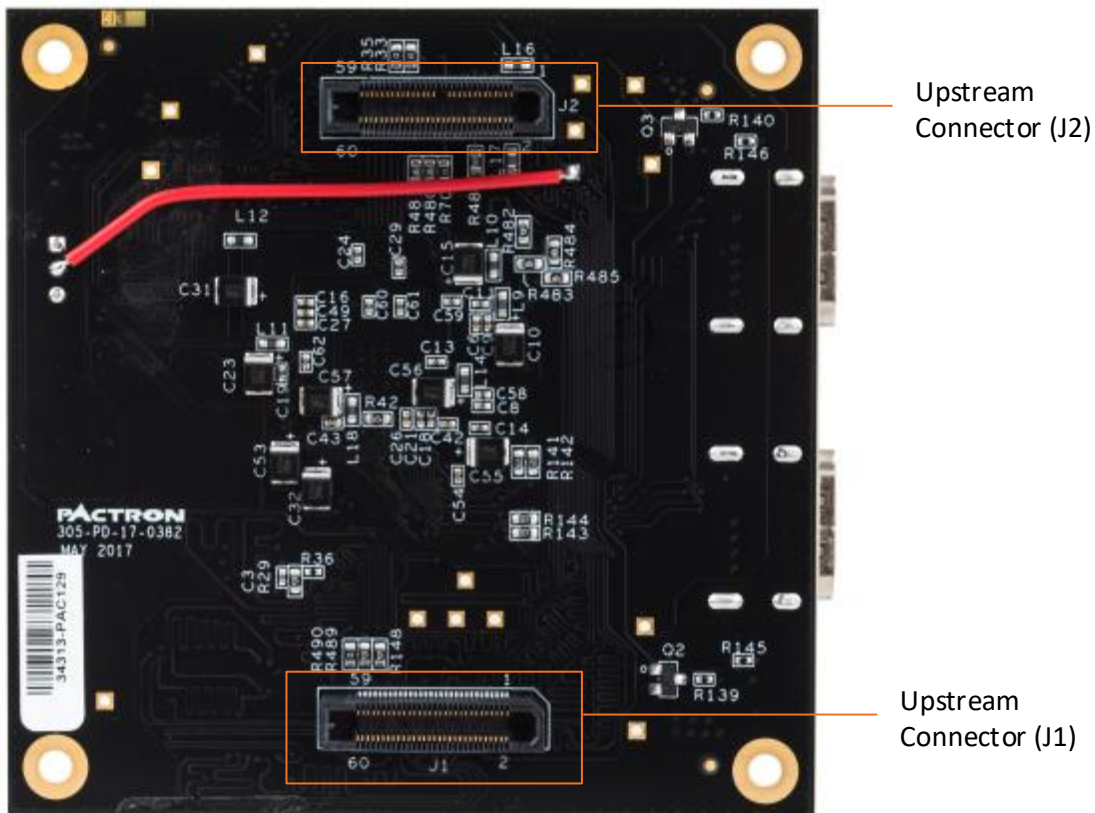

Figure 1.2. Bottom Side of HDMI VIP Input Bridge Board

1.2. Further Information

For more information on boards and kits available for the VIP system, visit <http://www.latticesemi.com/boards>.

For details about the Si1127A device, refer to [Si19127A/Si1127A HDMI Receiver with Deep Color Output Data Sheet \(Si1-DS-1059\)](#).

Refer to [Appendix A](#) and [Appendix B](#) for the schematics and BOM of the HDMI VIP Input Bridge board.

2. Functional Description

The Si1127A device receives up to 1080p @ 60 Hz HDMI-compliant digital audio and video from either HDMI Type A Connector Port 1 or Port 2 and transmits RGB or YCbCr parallel video and I²S or SPDIF audio to connectors J1 and J2. The Si1127A device does not support HDCP decryption, therefore can only receive unencrypted video.

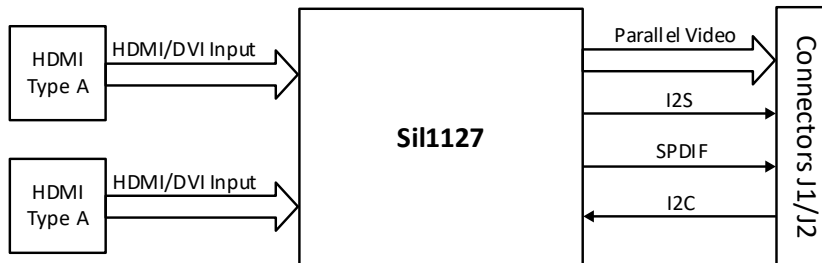

Figure 2.1 Functional Block Diagram

The Si1127A device is configured using the I²C interface from connector J2. The I²C registers monitor and control all functions of the Si1127A device, including selection of input. The Device Address Select Pin CI2CA on the Si1127A device is pulled low. Refer to Table 2.1 for the corresponding I²C Address. For configuration, refer to the SiI9223/9233/9127 HDMI Receivers Programmer's Reference (SiI-PR-1019) for detailed information. *The Programmer's Reference requires an NDA with Lattice Semiconductor.*

Table 2.1 Si1127A 7-bit I²C Address

Block	CI2CA = 0
Device Address	0x30

2.1. Switches

There is one push button switch, SW1, which controls the reset signal RX_RST. When pressing the push-button, logic 0 is sent to the Si1127A RESET# pin. RX_RST is connected to GSRN on connector J1, allowing SW1 to control the reset signal for other connected boards.

There is one slide switch, SW2, which is connected to GPIO3/MUTEOUT of the Si1127A device and Pin 28 of connector J2. When this connection is being driven by either Si1127A device or connector J2, SW2 should be placed in the HIGH position (4.7K Ω pull-up resistor to 3.3 V) to prevent any contention.

2.2. HDMI Interface

There are two HDMI Type A connectors for connecting the HDMI VIP Input Board to an HDMI Source. ESD protection is provided on the TMDS signals.

3. High-Speed Headers

There are two 60 pin high speed headers, connectors J1 and J2, used to connect to a host board.

Table 3.1 Connector J1

J1 Connector Pin	Signal Name	Sil1127A Pin
1	3.3 V	—
2	3.3 V	—
3	3.3 V	—
4	3.3 V	—
5	UP_GPIO31	Q30
6	UP_GPIO5	Q4
7	UP_GPIO32	Q31
8	UP_GPIO6	Q5
9	UP_GPIO33	Q32
10	UP_GPIO7	Q6
11	UP_GPIO34	Q33
12	UP_GPIO8	Q7
13	UP_GPIO1	Q0
14	UP_GPIO9	Q8
15	UP_GPIO2	Q1
16	UP_GPIO10	Q9
17	GND	—
18	GND	—
19	GND	—
20	GND	—
21	UP_GPIO13	Q12
22	GND	—
23	UP_GPIO11	Q10
24	UP_GPIO14	Q13
25	UP_GPIO35	Q34
26	UP_GPIO12	Q11
27	UP_GPIO36	Q35
28	UP_GPIO17	Q16
29	UP_GPIO25	Q24
30	UP_GPIO18	Q17

J1 Connector Pin	Signal Name	Sil1127A Pin
31	UP_GPIO26	Q25
32	UP_GPIO19	Q18
33	GND	—
34	UP_GPIO20	Q19
35	GND	—
36	GND	—
37	UP_GPIO27	Q26
38	GND	—
39	UP_GPIO28	Q27
40	GND	—
41	RX_SDO	SDO
42	UP_GPIO21	Q20
43	RX_WS	WS
44	UP_GPIO22	Q21
45	RX_SCK	SCK
46	UP_GPIO23	Q22
47	RX_MCLK	MCLK
48	UP_GPIO24	Q23
49	CEC_D	CEC_D
50	UP_GPIO29	Q28
51	RX_SCDT	GPIO1/SCDT
52	UP_GPIO30	Q29
53	GND	—
54	GND	—
55	GND	—
56	GND	—
57	2.5 V	—
58	2.5 V	—
59	2.5 V	—
60	2.5 V	—

Table 3.2 Connector J2

J2 Connector Pin	Signal Name	Si1127A pin
1	3.3 V	—
2	5 V	—
3	3.3 V	—
4	5 V	—
5	GND	—
6	5V	—
7	RODCK	ODCK
8	GND	—
9	GPIO0	GPIO0/XCLKOUT2
10	RVSYNC	VSYNC
11	GND	—
12	UP_GPIO15	Q14
13	RHSYNC	HSYNC
14	GND	—
15	UP_GPIO16	Q15
16	RX_INT	INT
17	GND	—
18	UP_GPIO4	Q3
19	RDE	DE
20	GND	—
21	UP_GPIO3	Q2
22	2.5 V	—

***Note:** Connected to SW2

J2 Connector Pin	Signal Name	Si1127A pin
23	GND	—
24	2.5 V	—
26	GND	—
28	RX_RST	RESET#
30	RX_MUTE	GPIO3/MUTEOUT*
32	RX_SPDIF	SPDIF
34	GND	—
40	GND	—
41	CSCL	CSCL
43	CSDA	CSDA
46	GND	—
52	GND	—
55	GND	—
57	GND	—
58	GND	—
59	GND	—
25, 27, 29,31, 33, 35, 36, 37, 38, 39, 42, 44, 45, 47, 48, 49, 50, 51, 53, 54, 56, 60	Not Connected	—

4. Power Supply

Board power is supplied through connectors J1 and J2.

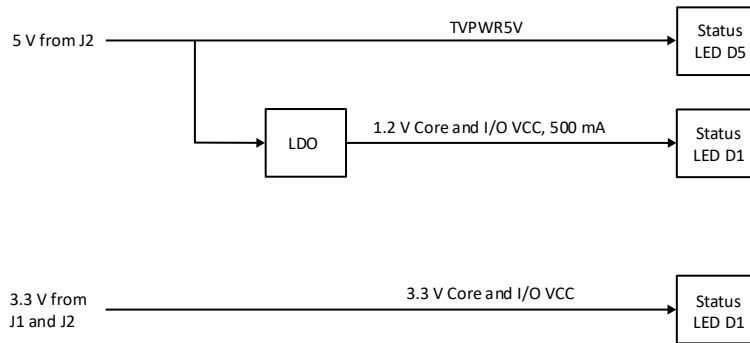

Figure 4.1. Power Supply

5. Status Indicators and Test Points

Three discrete LEDs are available to the user. These are driven by the Sil1127A.

Table 5.1 User LEDs

Signal	LED #	Sil1127A Pin	Color
PORT_1	D23	14 (GPIO4)	Green
PORT_2	D22	15 (GPIO5)	Green
SCDT	D25	12 (GPIO1/SDCT)	Green

Two discrete LEDs are used as status indicators. These are driven by the HDMI Ports.

Table 5.2 Status LEDs

Signal	LED #	Source	Color
RPWR1	D24	Port 1 - HDMI 5 V	Blue
RPWR2	D3	Port 2 - HDMI 5 V	Blue

Table 5.3 Test Points

Test Point	Connection
TP10	Sil1127A Pin16/GPIO6
TP11	Sil1127A Pin17/GPIO7
TP14	RPWR1
TP15	RPWR2
TP16	RX_MUTE
TP17	RX_SPDIF

6. Ordering Information

Visit www.latticesemi.com/boards for the latest ordering information.

Table 6.1 Reference Part Number

Description	Ordering Part Number
HDMI VIP Input Bridge Board	HDMI-VIP-IB-EVN

References

For more information, refer to:

- [SiI9127A/SiI1127A HDMI Receiver with Deep Color Output Data Sheet \(SiI-DS-1059\)](#)
- [SiI9223/9233/9127 HDMI Receivers Programmer's Reference \(SiI-PR-1019\)](#) (*The Programmer's Reference requires an NDA with Lattice Semiconductor*)
- [Lattice Embedded Vision Development Kit User Guide \(FPGA-UG-02015\)](#)
- [ECP5 VIP Processing Board \(FPGA-EB-02001\)](#)

Technical Support Assistance

Submit a technical support case through www.latticesemi.com/techsupport.

Appendix A. HDMI VIP Input Bridge Board Schematics

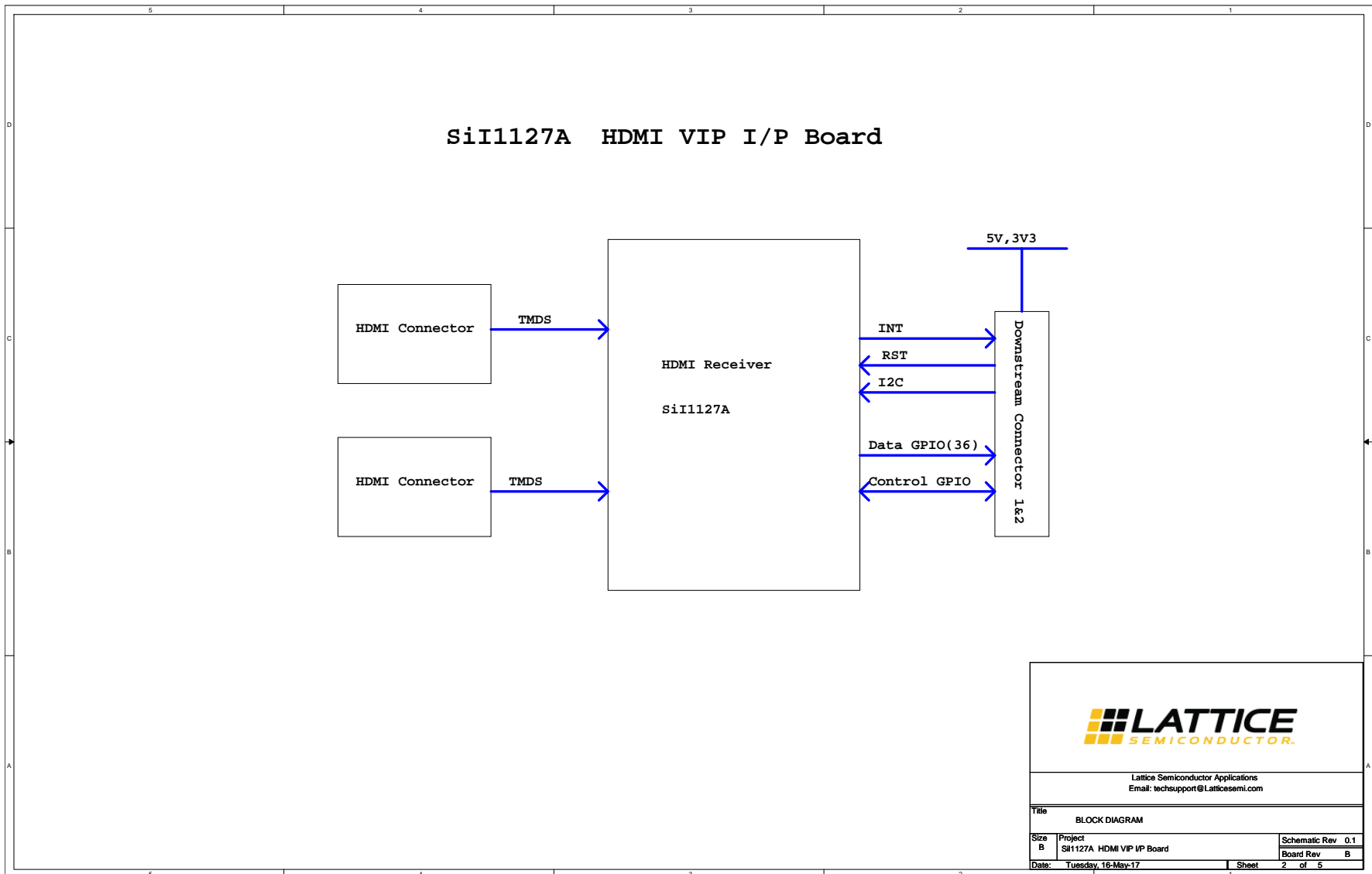

Figure A.1. Block Diagram

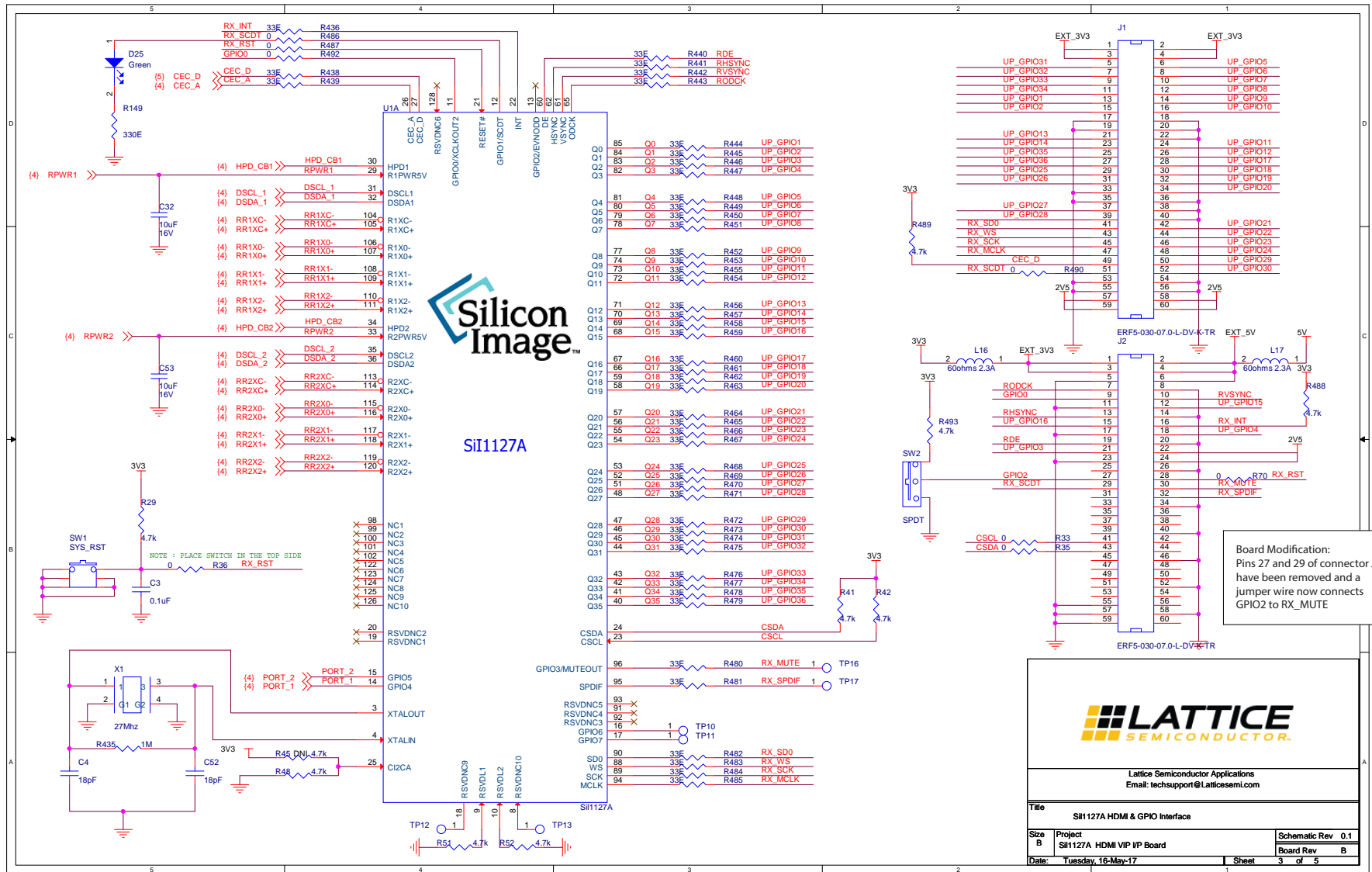

Figure A.2. Si1127A HDMI and GPIO Interface

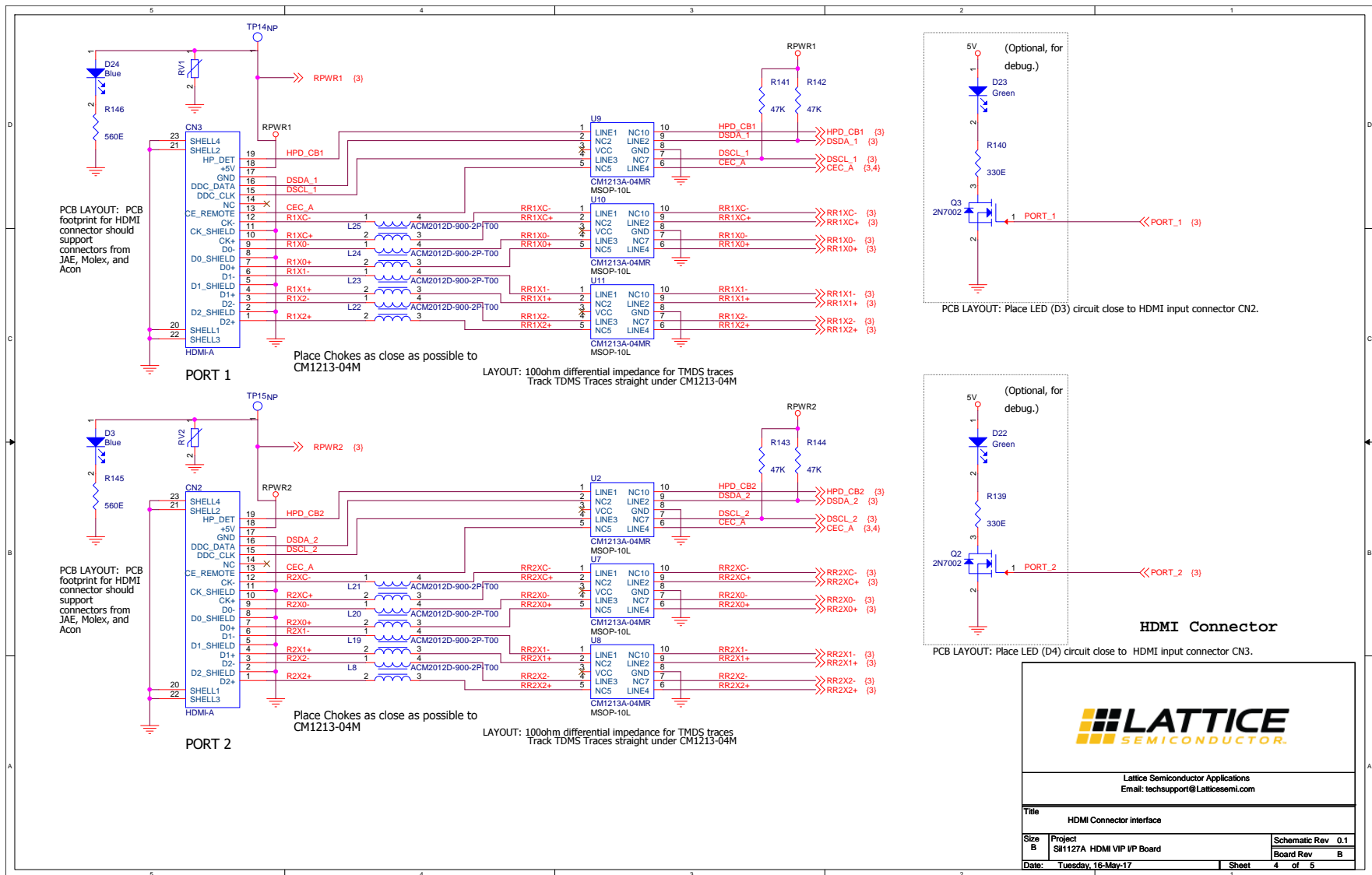

Figure A.3. HDMI Connector Interface

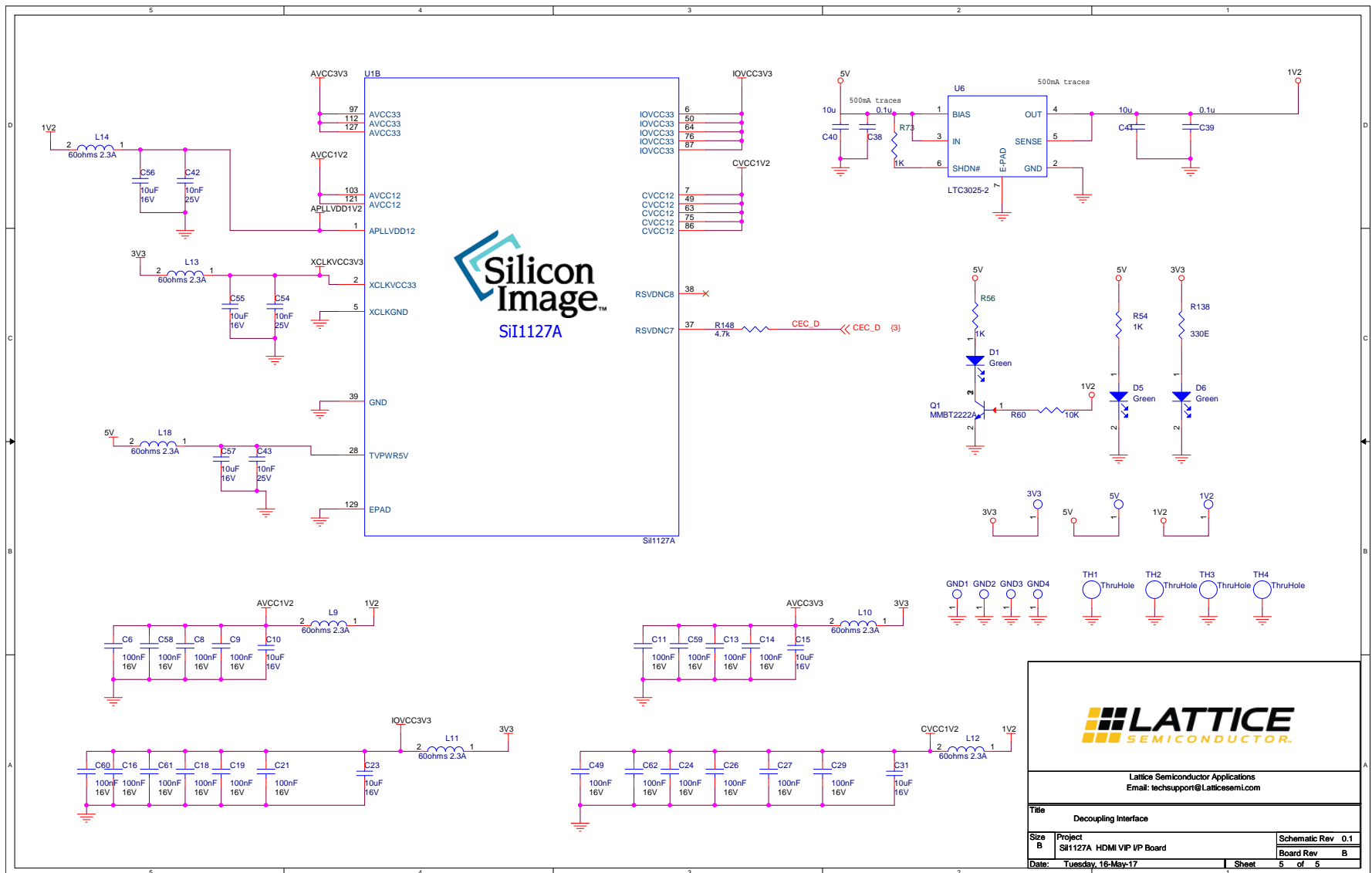

Figure A.4. Sii1127A Power Decoupling

Appendix B. HDMI VIP Input Bridge Board Bill of Materials

Item	Reference	Qty	Part	PART_NUMBER	Manufacturer	Description
1	CN2, CN3	2	HDMI-A	685119134923	Wurth Electronics	CONN RCPT HDMI 19POS SMD R/A
2	C3	1	0.1 μ F	C0402C104K4RACTU	Kemet	CAP CER 0.1 μ F 16V X7R 0402
3	C4, C52	2	18 pF	C0402C180K3GACTU	Kemet	CAP CER 18PF 25V C0G 0402
4	C6, C8, C9, C11, C13, C14, C16, C18, C19, C21, C24, C26, C27, C29, C49, C58, C59, C60, C61, C62	20	100 nF	C0402C104K4RACTU	Kemet	CAP CER 0.1 μ F 16 V X7R 0402
5	C10, C15, C23, C31, C32, C53, C55, C56, C57	9	10 μ F	THJB106K016SJN	AVX	Tantalum Capacitors – Solid SMD 16 V 10 μ F 10%
6	C38, C39	2	0.1 μ	CL05A104MP5NNNC	Samsung	CAP CER 0.1 μ F 10 V X5R 0402
7	C40, C41	2	10 μ	CL10X106MP8NRNC	Samsung	CAP CER 10 μ F 10 V 20% X6S 0603
8	C42, C43, C54	3	10 nF	ECJ0EB1E103K	Panasonic	CAP CER 10000 PF 25 V X7R 0402
9	D1, D5, D6, D22, D23, D25	6	Green	LTST-C190KGKT	LITE-On INC	LED GREEN CLEAR 0603 SMD
10	D3, D24	2	Blue	SMLE12BC7TT86	Rohm Semiconductor	LED BLUE CLEAR 0603 SMD
11	GND1, GND2, GND3, GND4, 5 V, TP10, TP11, TP12, 1V2, TP13, TP16, TP17, 3V3	13	TP_S_40_63	—	—	—
12	J1, J2	2	ERF5-030-07.0 -L-DV-K-TR	ERF5-030-07.0-L-DV-K-TR	Samtec Inc	Conn High Speed Edge Rate Terminal Strip HDR 60 POS 0.5mm Solder ST SMD T/R -
13	L8, L19, L20, L21, L22, L23, L24, L25	8	ACM2012D-900 -2P-T00	ACM2012D-900-2P-T00	TDK	CMC 300MA 2LN 90 OHM SMD
14	L9, L10, L11, L12, L13, L14, L16, L17, L18	9	60ohms 2.3A	MPZ1608Y600B	TDK	FERRITE BEAD 60 OHM 0603 1LN
15	Q1	1	MMBT2222A	MMBT2222A, 215	NXP Semiconductor	TRANS NPN 40V 0.6A SOT23
16	Q2, Q3	2	2N7002	2N7002	Fairchild Semiconductor	MOSFET N-CH 60V 115MA SOT-23
17	RV1, RV2	2	Varistor	AVRL101A1R1NTB	TDK	Varistor 0402 39V 1.1pF
18	R29, R41, R42, R48, R51, R52, R148, R488, R489, R493	10	4.7 K	CRCW06034K70FKEA	Vishay	RES SMD 4.7K Ω 1% 1/10W 0603
19	R33, R35, R70, R486, R487, R490, R492	7	0	RC0603JR-070RL	Yageo	RES SMD 0.0 Ω JUMPER 1/10W 0603
20	R36	1	0	RC0402JR-070RL	Yageo	RES SMD 0.0 Ω JUMPER 1/16W 0402
21	R45	1	4.7 K	CRCW06034K70FKEA	Vishay	RES SMD 4.7K Ω 1% 1/10W 0603
22	R54	1	1 K	RC0603FR-071KL	Yageo	RES SMD 1K Ω 1% 1/10W 0603
23	R56, R73	2	1 K	RMCF0402JT1K00	Stackpole Electronics Inc	RES SMD 1K Ω 5% 1/16W 0402
24	R60	1	10 K	ERJ-3EKF1002V	Panasonic	RES SMD 10K Ω 1% 1/10W 0603

Item	Reference	Qty	Part	PART_NUMBER	Manufacturer	Description
25	R138, R139, R140, R149	4	330 E	CRCW0402330RFKED	Vishay Dale	RES SMD 330 Ω 1% 1/16W 0402
26	R141, R142, R143, R144	4	47 K	ERA-3ARB473V	Panasonic	RES SMD 47K Ω 0.1% 1/10W 0603
27	R145, R146	2	560 E	CRCW0402560RFKED	Vishay Dale	RES SMD 560 Ω 1% 1/16W 0402
28	R435	1	1 M	ERJ-S03F1004V	Panasonic	RES SMD 1M Ω 1% 1/10W 0603
29	R436, R438, R439, R440, R441, R442, R443, R444, R445, R446, R447, R448, R449, R450, R451, R452, R453, R454, R455, R456, R457, R458, R459, R460, R461, R462, R463, R464, R465, R466, R467, R468, R469, R470, R471, R472, R473, R474, R475, R476, R477, R478, R479, R480, R481, R482, R483, R484, R485	49	33 E	CRCW060333R0FKEA	Vishay Dale	RES SMD 33 Ω 1% 1/10W 0603
30	SW1	1	SYS_RST	TL1015AF160QG	E-Switch	SWITCH TACTILE SPST-NO 0.05A 12V
31	SW2	1	SPDT	EG1218	E-Switch	SWITCH SLIDE SPDT 200MA 30V
32	TH1, TH2, TH3, TH4	4	ThruHole	—	—	—
33	TP14, TP15	2	NP	—	—	—
34	U1	1	SiI1127A	SiI1127ACTU	Lattice Semiconductor	PanelLink 4-Input HDMI Receiver
35	U2, U7, U8, U9, U10, U11	6	CM1213A-04MR	CM1213A-04MR	ON Semiconductor	TVS DIODE 3.3VWM 10VC 10MSOP
36	U6	1	LTC3025-2	LTC3025EDC-2#PBF	Linear Tech	LDO Regulator Pos 1.2V 0.5A 6-Pin DFN EP
37	X1	1	27 MHz	ABM8G-27.000MHZ-18-D2Y-T	ABRACON	CRYSTAL 27.0000MHZ 18PF SMD
38	HDMI Video Processing Input Board RevB PCB	1	—	305-PD-17-00XX	PACTRON	—

Revision History

Revision 1.1, July 2019

Section	Change Summary
—	Added Disclaimers section.
High Speed Headers	Updated J1 Connector Pin 42 in Table 3.1 Connector J1 .
Appendix A	Changed caption to Figure A.3. HDMI Connector Interface .
—	Minor revisions in formatting and style.

Revision 1.0, July 2017

Section	Change Summary
All	Initial release.



www.latticesemi.com