



# 3.3V CMOS 32-BIT BUS TRANSCEIVER WITH 3-STATE OUTPUTS, 5 VOLT TOLERANT I/O, BUS-HOLD

IDT74LVCH32245A

## FEATURES:

- Typical  $t_{sk(o)}$  (Output Skew) < 250ps
- ESD > 2000V per MIL-STD-883, Method 3015; > 200V using machine model (C = 200pF, R = 0)
- $V_{cc} = 3.3V \pm 0.3V$ , Normal Range
- $V_{cc} = 2.7V$  to  $3.6V$ , Extended Range
- CMOS power levels ( $0.4\mu W$  typ. static)
- All inputs, outputs, and I/O are 5V tolerant
- Supports hot insertion
- Available in 96-ball LFBGA package

## DRIVE FEATURES:

- Balanced Output Drivers:  $\pm 24mA$
- Reduced system switching noise

## APPLICATIONS:

- 5V and 3.3V mixed voltage systems
- Data communication and telecommunication systems

## DESCRIPTION:

This 32-bit bus transceiver is built using advanced dual metal CMOS technology. This high-speed, low power transceiver is ideal for asynchronous communication between two busses (A and B). The Direction and Output Enable controls are designed to operate the device as either four independent 8-bit transceivers or one 32-bit transceiver. The direction control pins (DIR) control the direction of data flow. The output enable pins (OE) override the direction control and disable both ports. All inputs are designed with hysteresis for improved noise margin.

All pins can be driven from either 3.3V or 5V devices. This feature allows the use of this device as a translator in a mixed 3.3V/5V supply system.

The LVCH32245A has been designed with a  $\pm 24mA$  output driver. This driver is capable of driving a moderate to heavy load while maintaining speed performance

The LVCH32245A has "bus-hold" which retains the inputs' last state whenever the input goes to a high impedance. This prevents floating inputs and eliminates the need for pull-up/down resistors.

## FUNCTIONAL BLOCK DIAGRAM

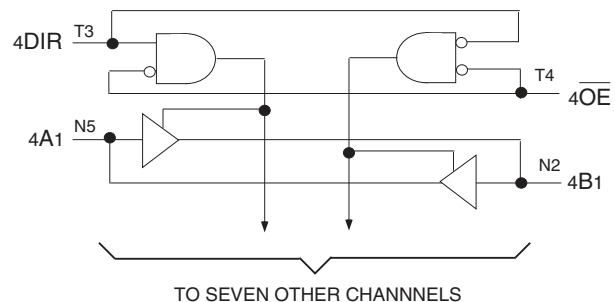
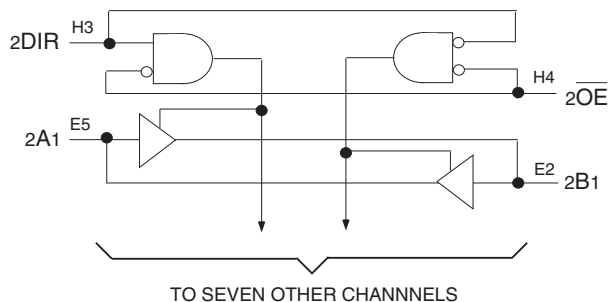
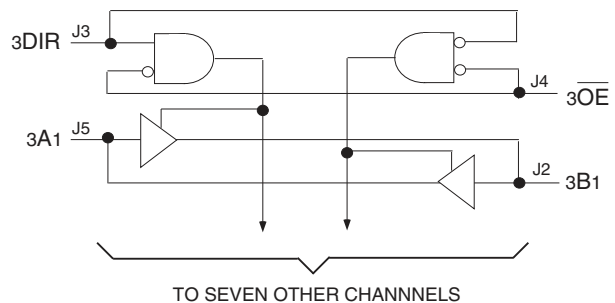
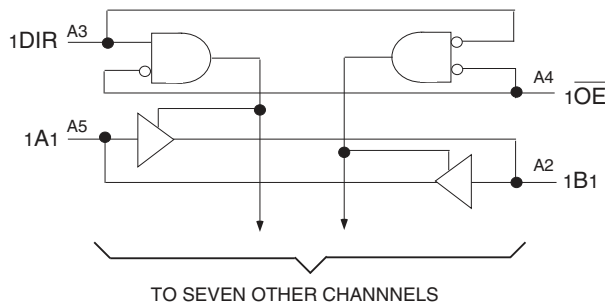

## PIN CONFIGURATION

6	1A2	1A4	1A6	1A8	2A2	2A4	2A6	2A7	3A2	3A4	3A6	3A8	4A2	4A4	4A6	4A7
5	1A1	1A3	1A5	1A7	2A1	2A3	2A5	2A8	3A1	3A3	3A5	3A7	4A1	4A3	4A5	4A8
4	1 $\overline{OE}$	GND	VCC	GND	GND	VCC	GND	2 $\overline{OE}$	3 $\overline{OE}$	GND	VCC	GND	GND	VCC	GND	4 $\overline{OE}$
3	1DIR	GND	VCC	GND	GND	VCC	GND	2DIR	3DIR	GND	VCC	GND	GND	VCC	GND	4DIR
2	1B1	1B3	1B5	1B7	2B1	2B3	2B5	2B8	3B1	3B3	3B5	3B7	4B1	4B3	4B5	4B8
1	1B2	1B4	1B6	1B8	2B2	2B4	2B6	2B7	3B2	3B4	3B6	3B8	4B2	4B4	4B6	4B7
	A	B	C	D	E	F	G	H	J	K	L	M	N	P	R	T

LFBGA  
TOPVIEW

## 96 BALL LFBGA PACKAGE ATTRIBUTES

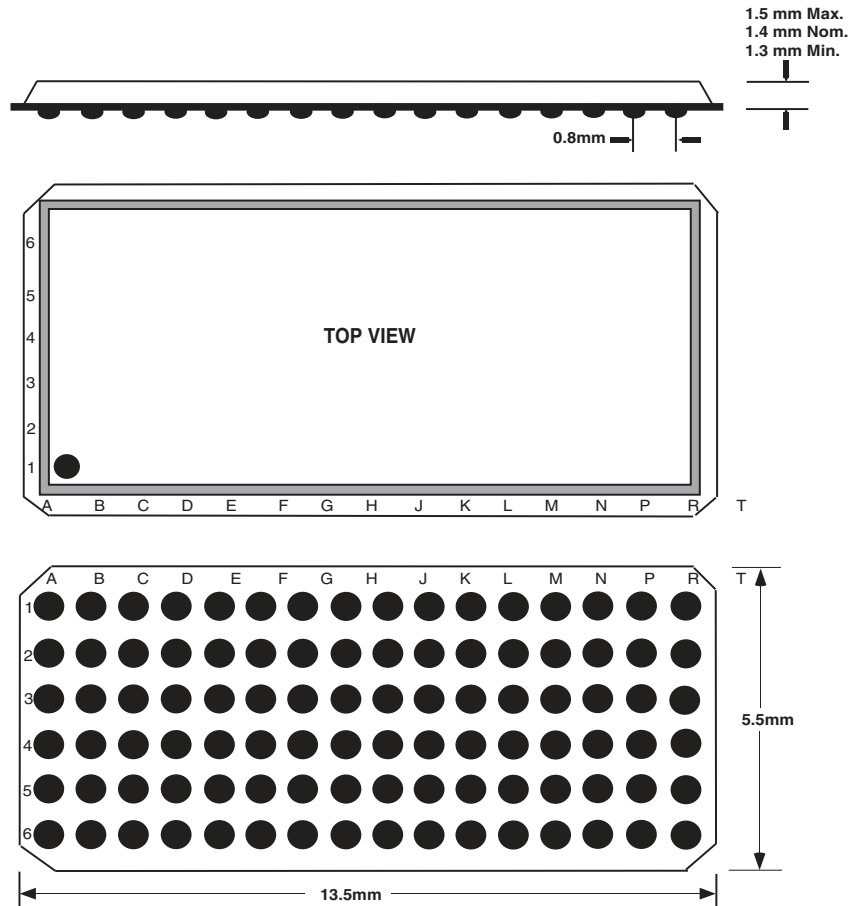

## ABSOLUTE MAXIMUM RATINGS<sup>(1)</sup>

Symbol	Description	Max	Unit
VTERM	Terminal Voltage with Respect to GND	-0.5 to +6.5	V
TSTG	Storage Temperature	-65 to +150	°C
IOUT	DC Output Current	-50 to +50	mA
I <sub>IK</sub> I <sub>OK</sub>	Continuous Clamp Current, V <sub>I</sub> < 0 or V <sub>O</sub> < 0	-50	mA
I <sub>CC</sub> I <sub>SS</sub>	Continuous Current through each V <sub>CC</sub> or GND	±100	mA

### NOTE:

- Stresses greater than those listed under ABSOLUTE MAXIMUM RATINGS may cause permanent damage to the device. This is a stress rating only and functional operation of the device at these or any other conditions above those indicated in the operational sections of this specification is not implied. Exposure to absolute maximum rating conditions for extended periods may affect reliability.

## CAPACITANCE (T<sub>A</sub> = +25°C, F = 1.0MHz)

Symbol	Parameter <sup>(1)</sup>	Conditions	Typ.	Max.	Unit
C <sub>IN</sub>	Input Capacitance	V <sub>IN</sub> = 0V	4.5	6	pF
C <sub>OUT</sub>	Output Capacitance	V <sub>OUT</sub> = 0V	6.5	8	pF
C <sub>I/O</sub>	I/O Port Capacitance	V <sub>IN</sub> = 0V	6.5	8	pF

### NOTE:

- As applicable to the device type.

## PIN DESCRIPTION

Pin Names	Description
$\overline{xOE}$	Output Enable Input (Active LOW)
xDIR	Direction Control Input
xAx	Side A Inputs or 3-State Outputs <sup>(1)</sup>
xBx	Side B Inputs or 3-State Outputs <sup>(1)</sup>

### NOTE:

- These pins have "Bus-Hold". All other pins are standard inputs, outputs, or I/Os.

## FUNCTION TABLE<sup>(1)</sup>

Inputs		Outputs
$\overline{xOE}$	xDIR	
L	L	Bus B data to Bus A
L	H	Bus A data to Bus B
H	X	Z

### NOTE:

- H = HIGH Voltage Level  
L = LOW Voltage Level  
X = Don't Care  
Z = High Impedance

## BUS-HOLD CHARACTERISTICS

Symbol	Parameter <sup>(1)</sup>	Test Conditions		Min.	Typ. <sup>(2)</sup>	Max.	Unit
IBHH IBHL	Bus-Hold Input Sustain Current	V <sub>CC</sub> = 3V	V <sub>I</sub> = 2V	-75	—	—	μA
			V <sub>I</sub> = 0.8V	75	—	—	
IBHH IBHL	Bus-Hold Input Sustain Current	V <sub>CC</sub> = 2.3V	V <sub>I</sub> = 1.7V	—	—	—	μA
			V <sub>I</sub> = 0.7V	—	—	—	
IBHHO IBHLO	Bus-Hold Input Overdrive Current	V <sub>CC</sub> = 3.6V	V <sub>I</sub> = 0 to 3.6V	—	—	±500	μA

### NOTES:

- Pins with Bus-Hold are identified in the pin description.
- Typical values are at V<sub>CC</sub> = 3.3V, +25°C ambient.

## DC ELECTRICAL CHARACTERISTICS OVER OPERATING RANGE

Following Conditions Apply Unless Otherwise Specified:

Operating Condition:  $T_A = -40^{\circ}\text{C}$  to  $+85^{\circ}\text{C}$

Symbol	Parameter	Test Conditions		Min.	Typ. <sup>(1)</sup>	Max.	Unit
V <sub>IH</sub>	Input HIGH Voltage Level	V <sub>CC</sub> = 2.3V to 2.7V		1.7	—	—	V
		V <sub>CC</sub> = 2.7V to 3.6V		2	—	—	
V <sub>IL</sub>	Input LOW Voltage Level	V <sub>CC</sub> = 2.3V to 2.7V		—	—	0.7	V
		V <sub>CC</sub> = 2.7V to 3.6V		—	—	0.8	
I <sub>IH</sub> I <sub>IL</sub>	Input Leakage Current	V <sub>CC</sub> = 3.6V	V <sub>I</sub> = 0 to 5.5V	—	—	±5	μA
I <sub>OZH</sub> I <sub>OZL</sub>	High Impedance Output Current (3-State Output pins)	V <sub>CC</sub> = 3.6V	V <sub>O</sub> = 0 to 5.5V	—	—	±10	μA
I <sub>OFF</sub>	Input/Output Power Off Leakage	V <sub>CC</sub> = 0V, V <sub>IN</sub> or V <sub>O</sub> ≤ 5.5V		—	—	±50	μA
V <sub>IK</sub>	Clamp Diode Voltage	V <sub>CC</sub> = 2.3V, I <sub>IN</sub> = -18mA		—	-0.7	-1.2	V
V <sub>H</sub>	Input Hysteresis	V <sub>CC</sub> = 3.3V		—	100	—	mV
I <sub>CC1</sub> I <sub>CC2</sub> I <sub>CC3</sub>	Quiescent Power Supply Current	V <sub>CC</sub> = 3.6V	V <sub>IN</sub> = GND or V <sub>CC</sub>	—	—	10	μA
			3.6 ≤ V <sub>IN</sub> ≤ 5.5V <sup>(2)</sup>	—	—	10	
ΔI <sub>CC</sub>	Quiescent Power Supply Current Variation	One input at V <sub>CC</sub> - 0.6V, other inputs at V <sub>CC</sub> or GND		—	—	500	μA

### NOTES:

- Typical values are at V<sub>CC</sub> = 3.3V, +25°C ambient.
- This applies in the disabled state only.

## OUTPUT DRIVE CHARACTERISTICS

Symbol	Parameter	Test Conditions <sup>(1)</sup>		Min.	Max.	Unit
V <sub>OH</sub>	Output HIGH Voltage	V <sub>CC</sub> = 2.3V to 3.6V	I <sub>OH</sub> = -0.1mA	V <sub>CC</sub> - 0.2	—	V
		V <sub>CC</sub> = 2.3V	I <sub>OH</sub> = -6mA	2	—	
		V <sub>CC</sub> = 2.3V	I <sub>OH</sub> = -12mA	1.7	—	
		V <sub>CC</sub> = 2.7V		2.2	—	
		V <sub>CC</sub> = 3V		2.4	—	
		V <sub>CC</sub> = 3V	I <sub>OH</sub> = -24mA	2.2	—	
V <sub>OL</sub>	Output LOW Voltage	V <sub>CC</sub> = 2.3V to 3.6V	I <sub>OL</sub> = 0.1mA	—	0.2	V
		V <sub>CC</sub> = 2.3V	I <sub>OL</sub> = 6mA	—	0.4	
			I <sub>OL</sub> = 12mA	—	0.7	
		V <sub>CC</sub> = 2.7V	I <sub>OL</sub> = 12mA	—	0.4	
		V <sub>CC</sub> = 3V	I <sub>OL</sub> = 24mA	—	0.55	

### NOTE:

- V<sub>IH</sub> and V<sub>IL</sub> must be within the min. or max. range shown in the DC ELECTRICAL CHARACTERISTICS OVER OPERATING RANGE table for the appropriate V<sub>CC</sub> range.  $T_A = -40^{\circ}\text{C}$  to  $+85^{\circ}\text{C}$ .

## OPERATING CHARACTERISTICS, $V_{CC} = 3.3V \pm 0.3V$ , $T_A = 25^\circ C$

Symbol	Parameter	Test Conditions	Typical	Unit
CPD	Power Dissipation Capacitance per Transceiver Outputs enabled	$C_L = 0pF$ , $f = 10MHz$	76	pF
CPD	Power Dissipation Capacitance per Transceiver Outputs disabled		8	

## SWITCHING CHARACTERISTICS<sup>(1)</sup>

Symbol	Parameter	$V_{CC} = 2.7V$		$V_{CC} = 3.3V \pm 0.3V$		Unit
		Min.	Max.	Min.	Max.	
$t_{PLH}$ $t_{PHL}$	Propagation Delay xAx to xBx, xBx to xAx	1.5	4.7	1	4	ns
$t_{PZH}$ $t_{PZL}$	Output Enable Time $\overline{xOE}$ to xAx or xBx	1.5	6.7	1.5	5.5	ns
$t_{PHZ}$ $t_{PLZ}$	Output Disable Time $\overline{xOE}$ to xAx or xBx	1.5	7.1	1.5	6.6	ns
$t_{PZH}$ $t_{PZL}$	Output Enable Time xDIR to xAx or xBx	1.5	7	1.5	5.5	ns
$t_{PHZ}$ $t_{PLZ}$	Output Disable Time xDIR to xAx or xBx	1.5	7.4	1.5	6.6	ns
tsk(o)	Output Skew <sup>(2)</sup>	—	—	—	500	ps

### NOTES:

- See TEST CIRCUITS AND WAVEFORMS.  $T_A = -40^\circ C$  to  $+85^\circ C$ .
- Skew between any two outputs of the same package and switching in the same direction.

## TEST CIRCUITS AND WAVEFORMS

### TEST CONDITIONS

Symbol	V <sub>CC</sub> <sup>(1)</sup> =3.3V±0.3V	V <sub>CC</sub> <sup>(1)</sup> =2.7V	V <sub>CC</sub> <sup>(2)</sup> =2.5V±0.2V	Unit
V <sub>LOAD</sub>	6	6	2 x V <sub>CC</sub>	V
V <sub>IH</sub>	2.7	2.7	V <sub>CC</sub>	V
V <sub>T</sub>	1.5	1.5	V <sub>CC</sub> / 2	V
V <sub>LZ</sub>	300	300	150	mV
V <sub>HZ</sub>	300	300	150	mV
C <sub>L</sub>	50	50	30	pF

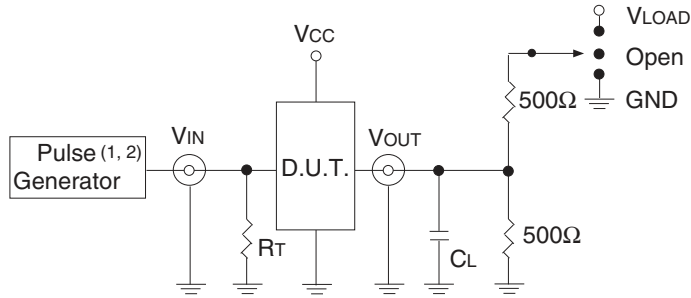

Test Circuit for All Outputs

#### DEFINITIONS:

C<sub>L</sub> = Load capacitance: includes jig and probe capacitance.  
R<sub>T</sub> = Termination resistance: should be equal to Z<sub>OUT</sub> of the Pulse Generator.

#### NOTES:

1. Pulse Generator for All Pulses: Rate ≤ 1.0MHz; t<sub>r</sub> ≤ 2.5ns; t<sub>r</sub> ≤ 2.5ns.
2. Pulse Generator for All Pulses: Rate ≤ 1.0MHz; t<sub>r</sub> ≤ 2ns; t<sub>r</sub> ≤ 2ns.

### SWITCH POSITION

Test	Switch
Open Drain Disable Low Enable Low	V <sub>LOAD</sub>
Disable High Enable High	GND
All Other Tests	Open

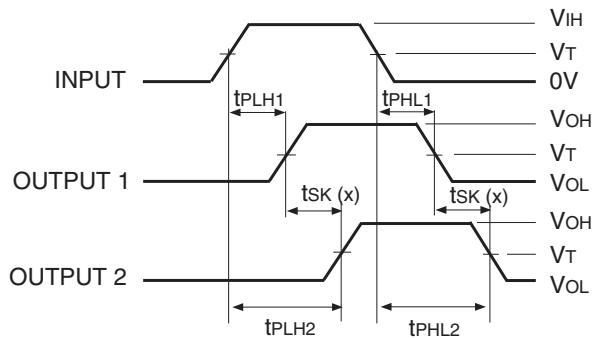

$$tsk(x) = |t_{PLH2} - t_{PLH1}| \text{ or } |t_{PHL2} - t_{PHL1}|$$

Output Skew - tsk(x)

#### NOTES:

1. For tsk(o) OUTPUT1 and OUTPUT2 are any two outputs.
2. For tsk(b) OUTPUT1 and OUTPUT2 are in the same bank.

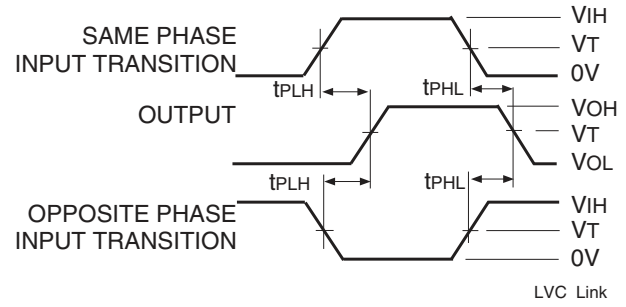

Propagation Delay

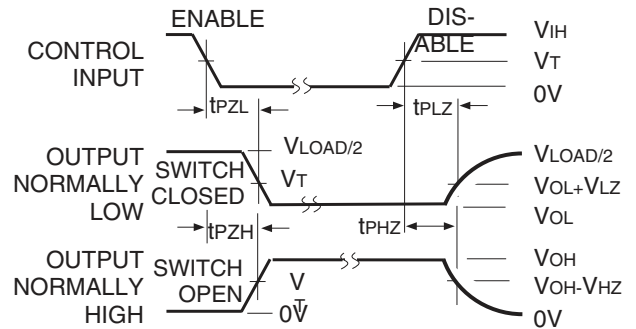

Enable and Disable Times

#### NOTE:

1. Diagram shown for input Control Enable-LOW and input Control Disable-HIGH.

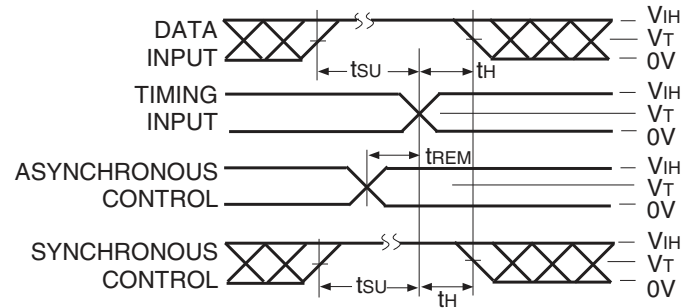

Set-up, Hold, and Release Times

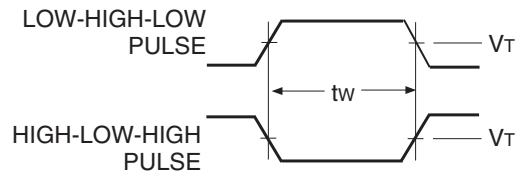

Pulse Width

## ORDERING INFORMATION

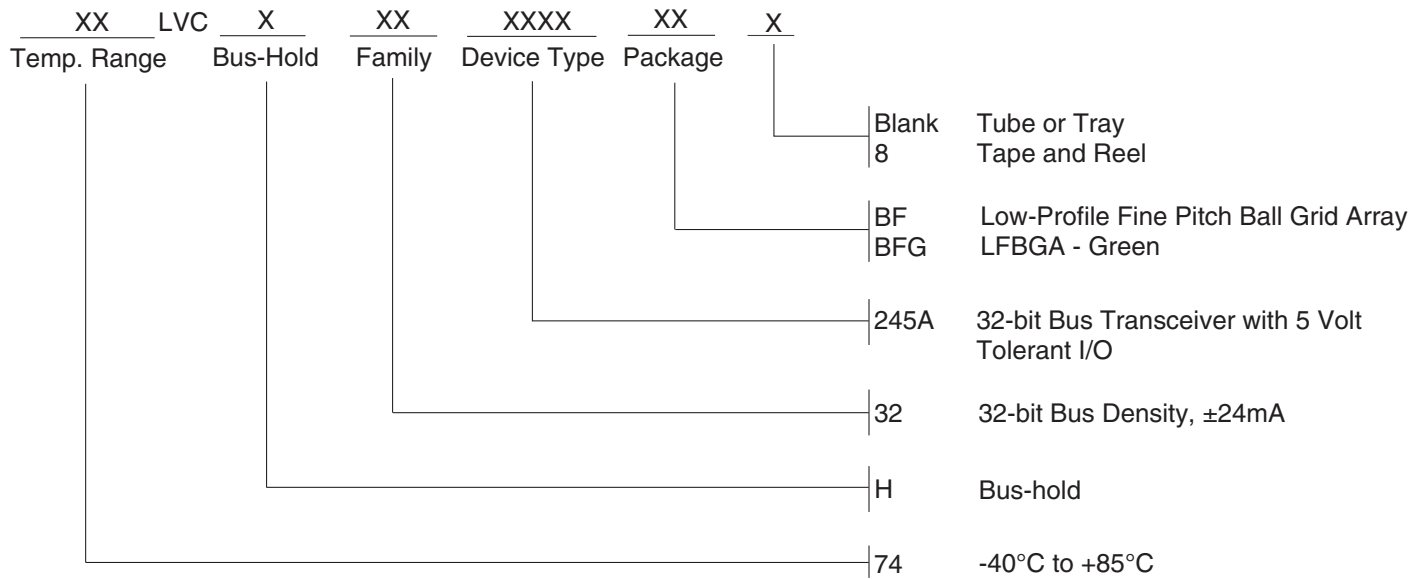

## Datasheet Document History

02/29/2016      Pg.7      Updated the ordering information by adding Tape and Reel.



**CORPORATE HEADQUARTERS**  
 6024 Silver Creek Valley Road  
 San Jose, CA 95138

**for SALES:**  
 800-345-7015 or 408-284-8200  
 fax: 408-284-2775  
 www.idt.com

**for Tech Support:**  
 logichelp@idt.com