

NOTES:

1.0 Materials

- 1.1 Body, and Clamp Nut: Steel. Corrosion Resistant per ASTM-A582. UNS No. S30300.
- 1.2 Center Conductor: Beryllium Copper per ASTM-B196. UNS C17300.
- 1.3 Solder Ferrule: Brass per ASTM-B16. UNS C36000.
- 1.4 O-Ring: Silicone Rubber per A-A-59588.
- 1.5 Dielectric Bead: Polychlorotrifluoroethylene (PCTFE) per ASTM-D1430-95. (KEL-F)

NOTE: Distance from end of cable center conductor to Re. Pl. is 0.250 (Ref)

2.0 Finishes

- 2.1 Center Contact and Solder Ferrule: Gold Plate per ASTM-B488 50 Microinches Min. thickness over Electrolytic Nickel Plate per ASTM-B689 50 Microinches Min. thickness.
 - 2.2 Body and Clamp Nut: Passivated per SAE-AMS-2700.
 - 2.3 O-Ring and Dielectric Bead: None.
- 3.0 Interface: 2.92mm Socket per CC-2.92mm-Soc. (Meets IEEE-STD-P287. Figure G.4. Except Conductor Tolerances and Contact Recession).

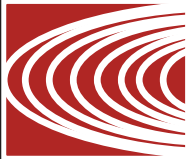

2.92mm Jack, Solder Clamp for Semflex HP160 Cable

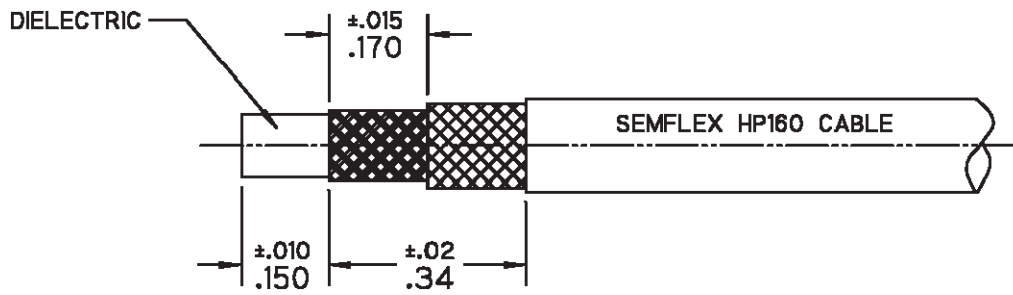

Step 1 1.1 Trim Cable as shown.

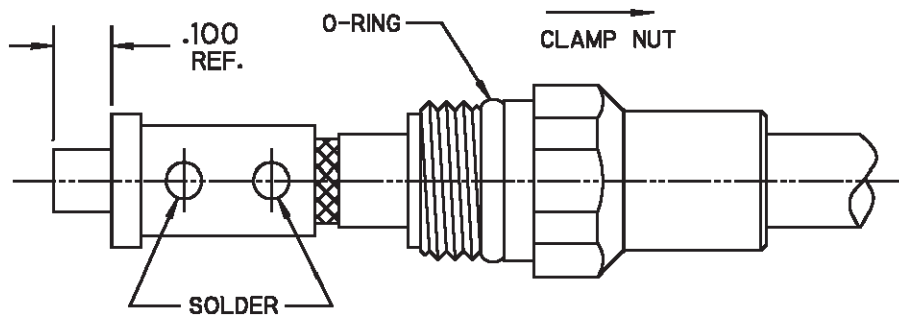

2.1 Install O-ring onto clamp nut where shown and slide clamp nut over cable in orientation shown.

Step 2 2.2 Insert cable into solder ferrule until seated and solder to cable braids where shown.

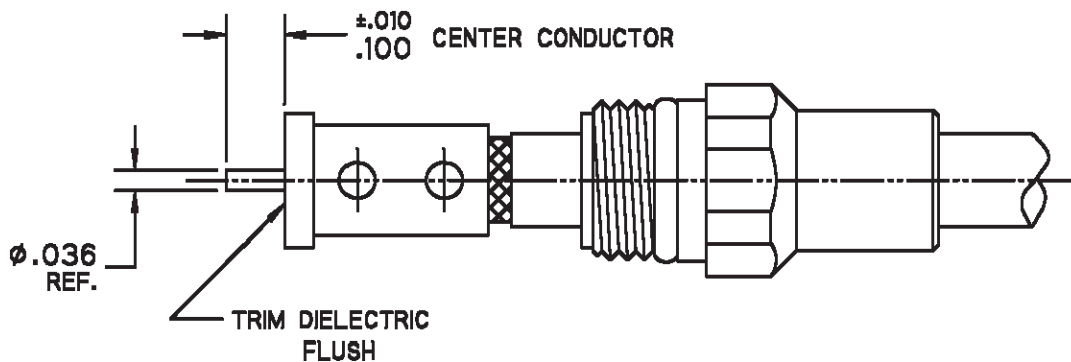

3.1 Trim dielectric flush with seating surface of solder ferrule.

Step 3 3.2 Verify center conductor dimension shown from ferrule seating surface.



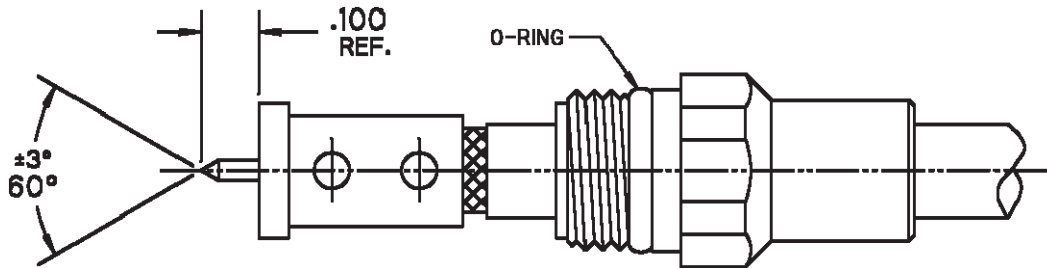

Step 4 4.1 Point cable center conductor as shown.

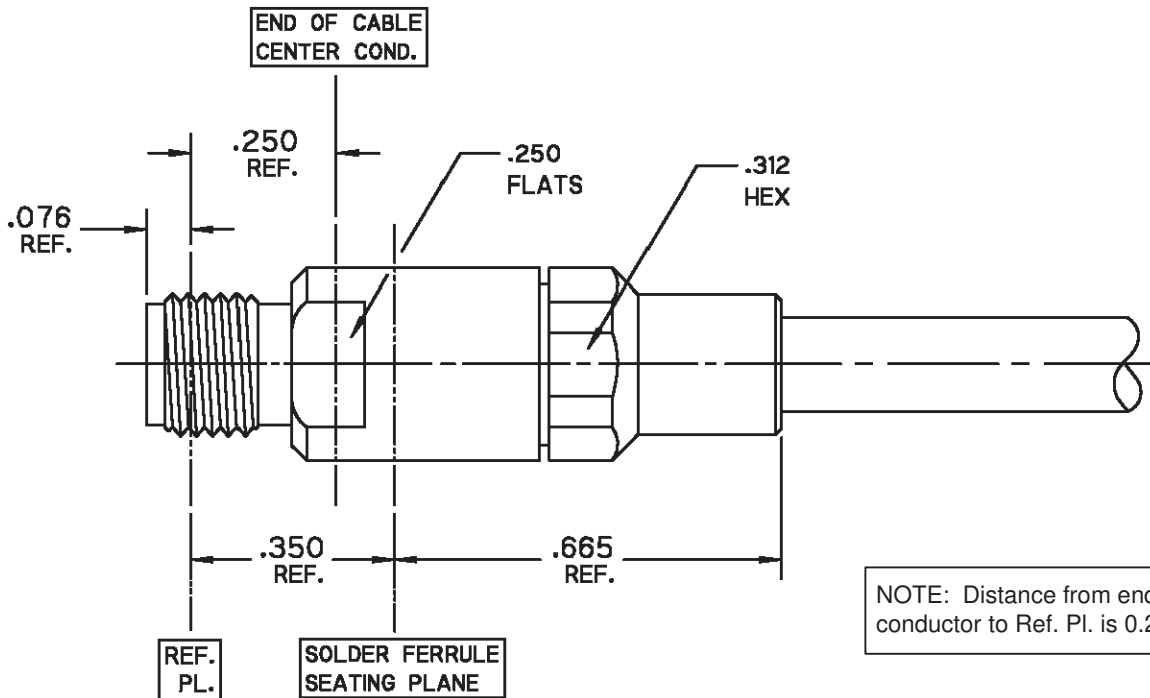

Step 5 5.1 Insert cable sub-assembly into connector until seated and tighten clamp nut to 25-35 in-lbs.

Product Control:

Crystek Part Number:	CS-FF-MSB	Release Date:	04-Jan-11
Revision Level:	A	Responsible:	K. Piotrowicz