



CY7C09569V
CY7C09579V

3.3V 16K/32K x 36 FLEx36™ Synchronous Dual-Port Static RAM

Features

- True dual-ported memory cells which allow simultaneous access of the same memory location
- Two Flow-Through/Pipelined devices
 - 16K x 36 organization (CY7C09569V)
 - 32K x 36 organization (CY7C09579V)
- 0.25-micron CMOS for optimum speed/power
- Three modes
 - Flow-Through
 - Pipelined
 - Burst
- Bus-Matching Capabilities on Right Port (x36 to x18 or x9)
- Byte-Select Capabilities on Left Port
- 100-MHz Pipelined Operation
- High-speed clock to data access 5/6/8 ns
- 3.3V Low operating power
 - Active = 250 mA (typical)
 - Standby = 10 μ A (typical)
- Fully synchronous interface for ease of use
- Burst counters increment addresses internally
 - Shorten cycle times
 - Minimize bus noise
 - Supported in Flow-Through and Pipelined modes
- Counter Address Read Back via I/O lines
- Single Chip Enable
- Automatic power-down
- Commercial and Industrial Temperature Ranges
- Compact package
 - 144-Pin TQFP (20 x 20 x 1.4 mm)
 - 144-Pin Pb-Free TQFP (20 x 20 x 1.4 mm)
 - 172-Ball BGA (1.0-mm pitch) (15 x 15 x 0.51 mm)

Logic Block Diagram

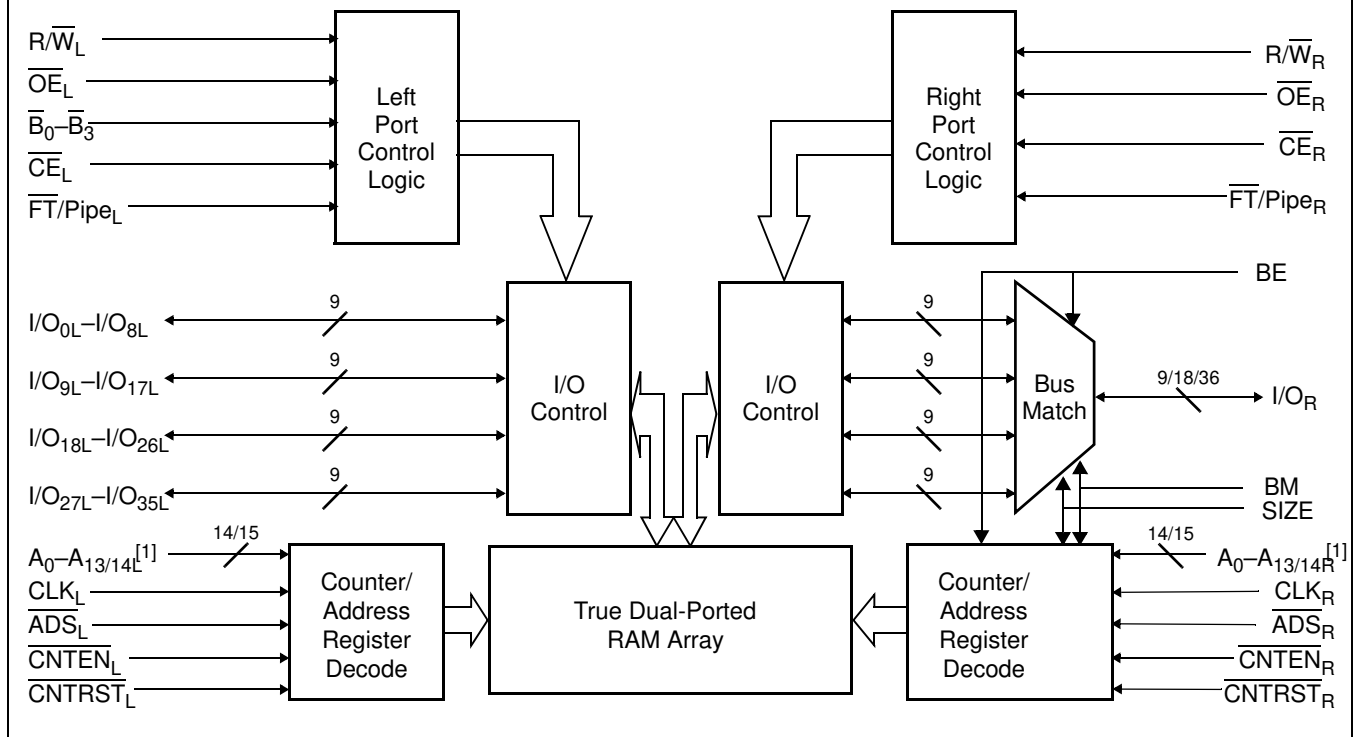

Note:
 1. A_0-A_{13} for 16K; A_0-A_{14} for 32K devices.

Functional Description

The CY7C09569V and CY7C09579V are high-speed 3.3V synchronous CMOS 16K and 32K x 36 dual-port static RAMs. Two ports are provided, permitting independent, simultaneous access for reads and writes to any location in memory. Registers on control, address, and data lines allow for minimal set-up and hold times. In pipelined output mode, data is registered for decreased cycle time. Clock to data valid $t_{CD2} = 5$ ns (pipelined). Flow-through mode can also be used to bypass the pipelined output register to eliminate access latency. In flow-through mode data will be available $t_{CD1} = 12.5$ ns after the address is clocked into the device. Pipelined output or flow-through mode is selected via the FT/Pipe pin.

Each port contains a burst counter on the input address register. The internal write pulse width is independent of the external R/W LOW duration. The internal write pulse is self-timed to allow the shortest possible cycle times.

A HIGH on \overline{CE} for one clock cycle will power down the internal circuitry to reduce the static power consumption. In the pipelined mode, one cycle is required with \overline{CE} LOW to reactivate the outputs.

Counter Enable Inputs are provided to stall the operation of the address input and utilize the internal address generated by the internal counter for fast interleaved memory applications. A port's burst counter is loaded with the port's Address Strobe (ADS). When the port's Count Enable (\overline{CNTEN}) is asserted, the address counter will increment on each LOW-to-HIGH transition of that port's clock signal. This will read/write one word from/into each successive address location until \overline{CNTEN} is deasserted. The counter can address the entire memory array and will loop back to the start. Counter Reset (\overline{CNTRST}) is used to reset the burst counter.

All parts are available in 144-Pin Thin Quad Plastic Flatpack (TQFP), 144-Pin Pb-Free Thin Quad Plastic Flatpack (TQFP) and 172-Ball Ball Grid Array (BGA) packages.

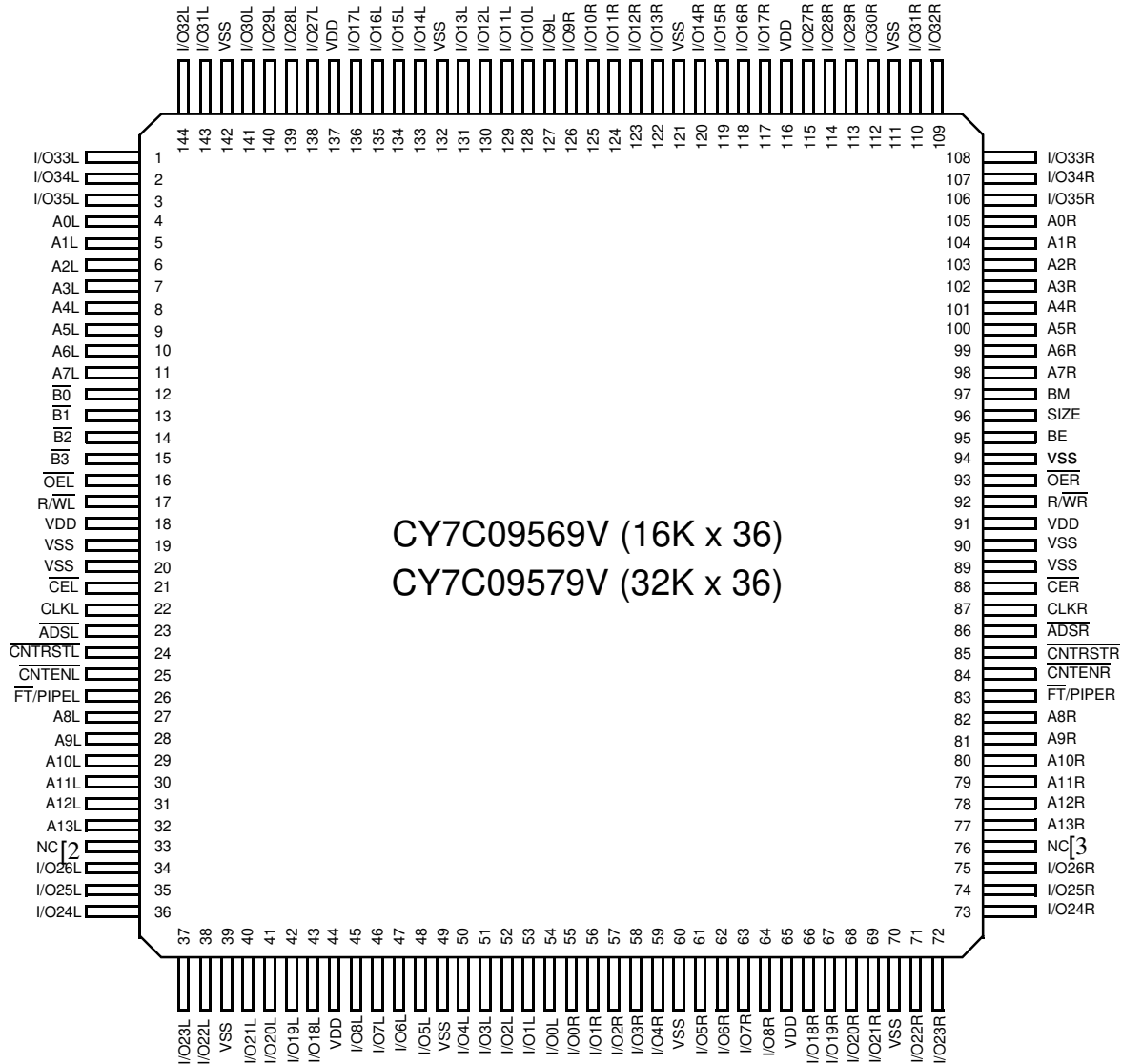
Pin Configurations
144-Pin Thin Quad Flatpack (TQFP)
Top View

Notes:

2. This pin is A14L for CY7C09579V.
3. This pin is A14R for CY7C09579V.

Pin Configurations (continued)

172-Ball Ball Grid Array (BGA)
Top View

	1	2	3	4	5	6	7	8	9	10	11	12	13	14
A	I/O32L	I/O30L	NC	VSS	I/O13L	VDD	I/O11L	I/O11R	VDD	I/O13R	VSS	NC	I/O30R	I/O32R
B	A0L	I/O33L	I/O29	I/O17L	I/O14L	I/O12L	I/O9L	I/O9R	I/O12R	I/O14R	I/O17R	I/O29R	I/O33R	A0R
C	NC	A1L	I/O31L	I/O27L	NC	I/O15L	I/O10L	I/O10R	I/O15R	NC	I/O27R	I/O31R	A1R	NC
D	A2L	A3L	I/O35L	I/O34L	I/O28L	I/O16L	VSS	VSS	I/O16R	I/O28R	I/O34R	I/O35R	A3R	A2R
E	A4L	A5L	NC	$\overline{B0L}$	NC	NC			NC	NC	BM	NC	A5R	A4R
F	VDD	A6L	A7L	$\overline{B1L}$	NC					NC	SIZE	A7R	A6R	VDD
G	$\overline{OE1}$	$\overline{B2L}$	$\overline{B3L}$	$\overline{CE1}$							$\overline{CE1}$	VSS	BE	$\overline{OE1}$
H	VSS	$\overline{R/WL}$	A8L	CLKL							CLKR	A8R	$\overline{R/WR}$	VSS
J	A9L	A10L	VSS	\overline{ADSL}	NC					NC	\overline{ADSR}	VSS	A10R	A9R
K	A11L	A12L	NC	$\overline{CNTRSTL}$	NC	NC			NC	NC	$\overline{CNTRSTR}$	NC	A12R	A11R
L	$\overline{FT/PIPEL}$	A13L	\overline{CNTENL}	I/O26L	I/O25L	I/O19L	VSS	VSS	I/O19R	I/O25R	I/O26R	\overline{CNTENR}	A13R	$\overline{FT/PIPER}$
M	NC	NC ^[2]	I/O22L	I/O18L	NC	I/O7L	I/O2L	I/O2R	I/O7R	NC	I/O18R	I/O22R	NC ^[3]	NC
N	I/O24L	I/O20L	I/O8L	I/O6L	I/O5L	I/O3L	I/O0L	I/O0R	I/3R	I/O5R	I/O6R	I/O8R	I/O20R	I/O24R
P	I/O23L	I/O21L	NC	VSS	I/O4L	VDD	I/O1L	I/O1R	VDD	I/O4R	VSS	NC	I/O21R	I/O23R

Selection Guide

	CY7C09569V CY7C09579V -100	CY7C09569V CY7C09579V -83	CY7C09569V CY7C09579V -67	Unit
f_{MAX2} (Pipelined)	100	83	67	MHz
Max. Access Time (Clock to Data, Pipelined)	5	6	8	ns
Typical Operating Current I_{CC}	250	240	230	mA
Typical Standby Current for I_{SB1} (Both Ports TTL Level)	30	25	25	mA
Typical Standby Current for I_{SB3} (Both Ports CMOS Level)	10	10	10	μ A

Pin Definitions

Left Port	Right Port	Description
$A_{0L}-A_{13/14L}$	$A_{0R}-A_{13/14R}$	Address Inputs (A_0-A_{13} for 16K, A_0-A_{14} for 32K devices).
ADS_L	ADS_R	Address Strobe Input. Used as an address qualifier. This signal should be asserted LOW to assert the part using the externally supplied address on Address Pins. To load this address into the Burst Address Counter both ADS and CNTEN have to be LOW. ADS is disabled if CNTRST is asserted LOW
CE_L	CE_R	Chip Enable Input.
CLK_L	CLK_R	Clock Signal. This input can be free-running or strobed. Maximum clock input rate is f_{MAX} .
$CNTEN_L$	$CNTEN_R$	Counter Enable Input. Asserting this signal <u>LOW</u> increments the burst address counter of its respective port on each rising edge of CLK. CNTEN is disabled if CNTRST is asserted LOW.
$CNTRST_L$	$CNTRST_R$	Counter Reset Input. Asserting this signal <u>LOW</u> resets the burst address counter of its respective port to zero. CNTRST is not disabled by asserting ADS or CNTEN.
$I/O_{0L}-I/O_{35L}$	$I/O_{0R}-I/O_{35R}$	Data Bus Input/Output.
OE_L	OE_R	Output Enable Input. This signal must be asserted LOW to enable the I/O data pins during read operations.
R/W_L	R/W_R	Read/Write Enable Input. This signal is asserted LOW to write to the dual port memory array. For read operations, assert this pin HIGH.
$FT/PIPE_L$	$FT/PIPE_R$	Flow-Through/Pipelined Select Input. For flow-through mode operation, assert this pin LOW. For pipelined mode operation, assert this pin HIGH.
$B_{0L}-B_{3L}$		Byte Select Inputs. Asserting these signals enable read and write operations to the corresponding bytes of the memory array.
	BM, SIZE	Select Pins for Bus Matching. See Bus Matching for details.
	BE	Big Endian Pin. See Bus Matching for details.
V_{SS}		Ground Input.
V_{DD}		Power Input.



Maximum Ratings [4]

(Above which the useful life may be impaired. For user guidelines, not tested.)

- Storage Temperature -65°C to +150°C
- Ambient Temperature with Power Applied.....-55°C to +125°C
- Supply Voltage to Ground Potential -0.5V to +4.6V
- DC Voltage Applied to Outputs in High Z State.....-0.5V to V_{DD}+0.5V
- DC Input Voltage..... -0.5V to V_{DD}+0.5V^[5]

- Output Current into Outputs (LOW)..... 20 mA
- Static Discharge Voltage..... >2001V
- Latch-Up Current..... >200 mA

Operating Range

Range	Ambient Temperature	V _{DD}
Commercial	0°C to +70°C	3.3V ± 165 mV
Industrial	-40°C to +85°C	3.3V ± 165 mV

Electrical Characteristics Over the Operating Range

Parameter	Description	CY7C09569V CY7C09579V									Unit	
		-100			-83			-67				
		Min.	Typ.	Max.	Min.	Typ.	Max.	Min.	Typ.	Max.		
V _{OH}	Output HIGH Voltage (V _{DD} = Min., I _{OH} = -4.0 mA)	2.4			2.4			2.4			V	
V _{OL}	Output LOW Voltage (V _{DD} = Min., I _{OL} = +4.0 mA)			0.4			0.4			0.4	V	
V _{IH}	Input HIGH Voltage	2.0			2.0			2.0			V	
V _{IL}	Input LOW Voltage			0.8			0.8			0.8	V	
I _{OZ}	Output Leakage Current	-10		10	-10		10	-10		10	μA	
I _{CC}	Operating Current (V _{DD} = Max., I _{OUT} = 0 mA) Outputs Disabled	Commercial		250	385		240	360		230	340	mA
		Industrial					270	385				mA
I _{SB1}	Standby Current (Both Ports TTL Level) CE _L & CE _R ≥ V _{IH} , f = f _{MAX}	Commercial		30	75		25	70		25	65	mA
		Industrial					35	85				mA
I _{SB2}	Standby Current (One Port TTL Level) CE _L CE _R ≥ V _{IH} , f = f _{MAX}	Commercial		170	220		160	210		150	200	mA
		Industrial					170	235				mA
I _{SB3}	Standby Current (Both Ports CMOS Level) CE _L & CE _R ≥ V _{DD} - 0.2V, f = 0	Commercial		0.01	1		0.01	1		0.01	1	mA
		Industrial					0.01	1				mA
I _{SB4}	Standby Current (One Port CMOS Level) CE _L CE _R ≥ V _{IH} , f = f _{MAX}	Commercial		150	200		140	190		130	180	mA
		Industrial					150	200				mA

Capacitance

Parameter	Description	Test Conditions	Max.	Unit
C _{IN}	Input Capacitance	T _A = 25°C, f = 1 MHz, V _{DD} = 3.3V	10	pF
C _{OUT}	Output Capacitance		10	pF

Note:

- 4. The voltage on any input or I/O pin can not exceed the power pin during power-up.
- 5. Pulse width < 20 ns.

AC Test Load and Waveforms

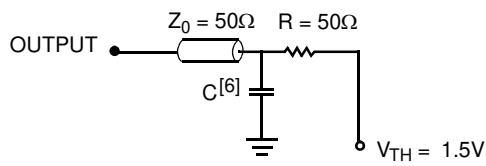

(a) Normal Load (Load 1)

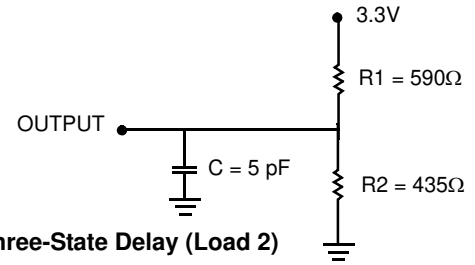

(b) Three-State Delay (Load 2)

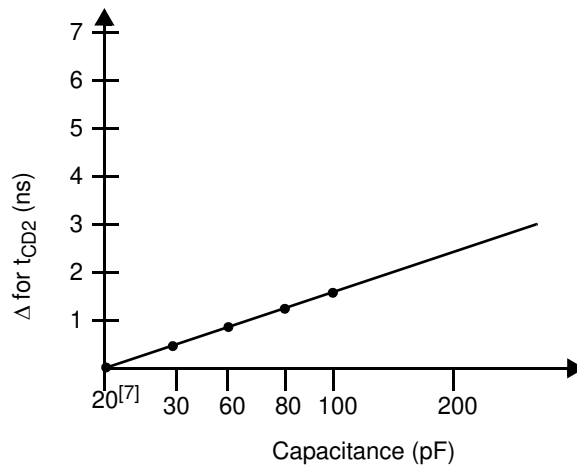
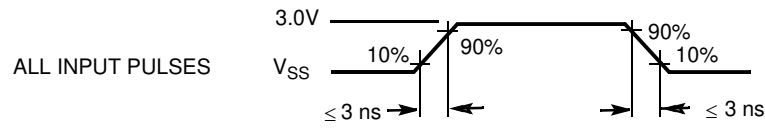

(b) Load Derating Curve

Notes:

- 6. External AC Test Load Capacitance = 10 pF.
- 7. (Internal I/O pad Capacitance = 10 pF) + AC Test Load.

Switching Characteristics Over the Operating Range

Parameter	Description	CY7C09569V CY7C09579V						Unit
		-100		-83		-67		
		Min.	Max.	Min.	Max.	Min.	Max.	
f _{MAX1}	f _{Max} Flow-Through		67		45		40	MHz
f _{MAX2}	f _{Max} Pipelined		100		83		67	MHz
t _{CYC1}	Clock Cycle Time - Flow-Through	15		22		25		ns
t _{CYC2}	Clock Cycle Time - Pipelined	10		12		15		ns
t _{CH1}	Clock HIGH Time - Flow-Through	6.5		7.5		8.5		ns
t _{CL1}	Clock LOW Time - Flow-Through	6.5		7.5		8.5		ns
t _{CH2}	Clock HIGH Time - Pipelined	4		5		6.5		ns
t _{CL2}	Clock LOW Time - Pipelined	4		5		6.5		ns
t _R	Clock Rise Time		3		3		3	ns
t _F	Clock Fall Time		3		3		3	ns
t _{SA}	Address Set-Up Time	3.5		4		4		ns
t _{HA}	Address Hold Time	0.5		0.5		0.5		ns
t _{SB}	Byte Select Set-Up Time	3.5		4		4		ns
t _{HB}	Byte Select Hold Time	0.5		0.5		0.5		ns
t _{SC}	Chip Enable Set-Up Time	3.5		4		4		ns
t _{HC}	Chip Enable Hold Time	0.5		0.5		0.5		ns
t _{SW}	R/W Set-Up Time	3.5		4		4		ns
t _{HW}	R/W Hold Time	0.5		0.5		0.5		ns
t _{SD}	Input Data Set-Up Time	3.5		4		4		ns
t _{HD}	Input Data Hold Time	0.5		0.5		0.5		ns
t _{SAD}	ADS Set-Up Time	3.5		4		4		ns
t _{HAD}	ADS Hold Time	0.5		0.5		0.5		ns
t _{SCN}	CNTEN Set-Up Time	3.5		4		4		ns
t _{HCN}	CNTEN Hold Time	0.5		0.5		0.5		ns
t _{SRST}	CNTRST Set-Up Time	3.5		4		4		ns
t _{HRST}	CNTRST Hold Time	0.5		0.5		0.5		ns
t _{OE}	Output Enable to Data Valid		8		9		10	ns
t _{OLZ} ^[8, 9]	OE to Low Z	2		2		2		ns
t _{OHZ} ^[8, 9]	OE to High Z	1	7	1	7	1	7	ns
t _{CD1}	Clock to Data Valid - Flow-Through		12.5		18		20	ns
t _{CD2}	Clock to Data Valid - Pipelined		5		6		8	ns
t _{CA1}	Clock to Counter Address Valid - Flow-Through		12.5		18		20	ns
t _{CA2}	Clock to Counter Address Valid - Pipelined		9		10		11	ns
t _{DC}	Data Output Hold After Clock HIGH	2		2		2		ns
t _{CKHZ} ^[8, 9]	Clock HIGH to Output High Z	2	6	2	7	2	8	ns
t _{CKLZ} ^[8, 9]	Clock HIGH to Output Low Z	2		2		2		ns

Notes:

8. This parameter is guaranteed by design, but it is not production tested.
9. Test conditions used are Load 2.

Switching Characteristics Over the Operating Range (continued)

Parameter	Description	CY7C09569V CY7C09579V						Unit
		-100		-83		-67		
		Min.	Max.	Min.	Max.	Min.	Max.	
Port to Port Delays								
t _{CWDD}	Write Port Clock HIGH to Read Data Delay		30		35		35	ns
t _{CCS}	Clock to Clock Set-Up Time		9		10		12	ns

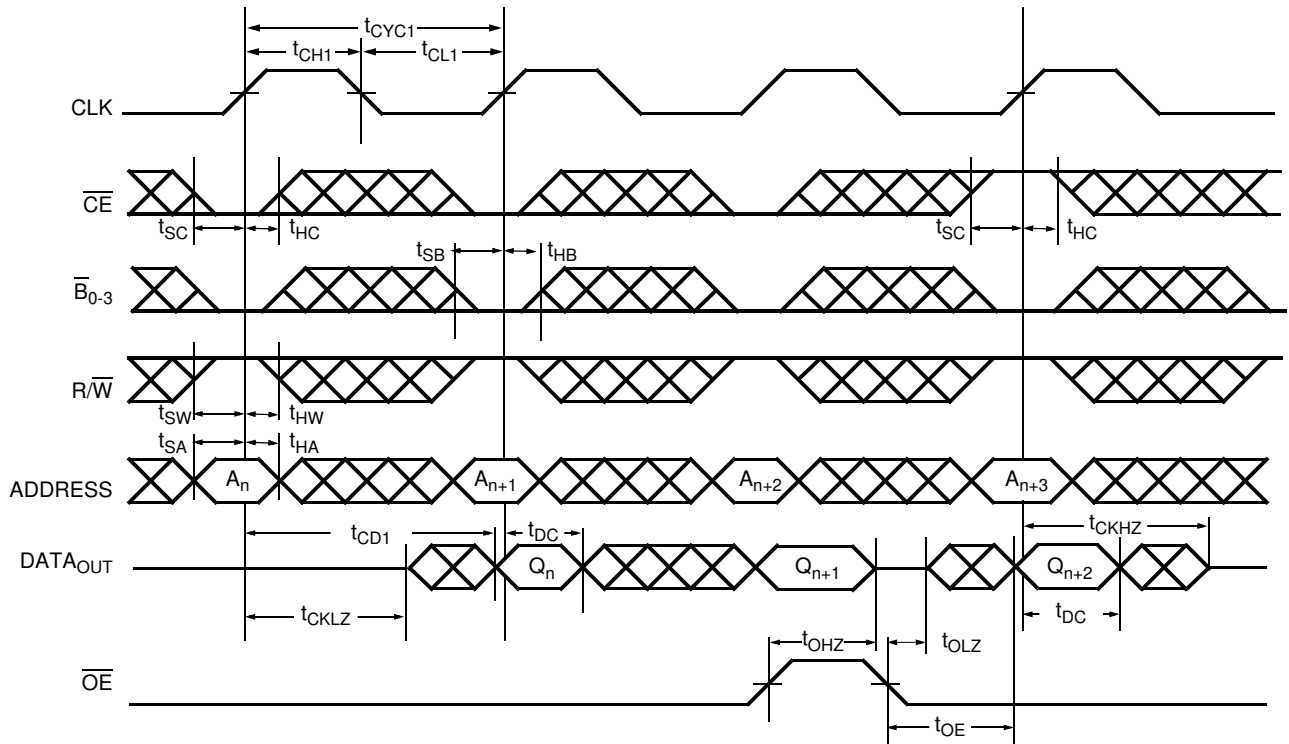
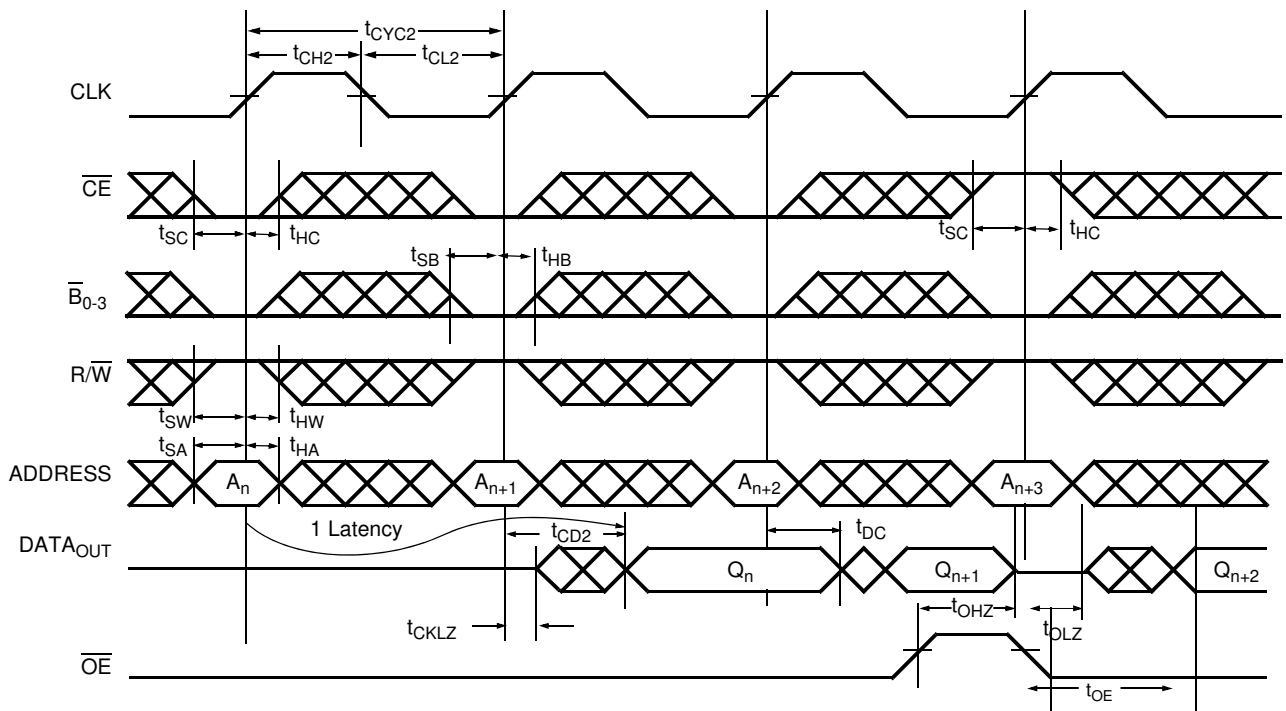
Switching Waveforms
Read Cycle for Flow-Through Output ($\overline{FT}/PIPE = V_{IL}$)^[10, 11, 12, 13]

Read Cycle for Pipelined Operation ($\overline{FT}/PIPE = V_{IH}$)^[10, 11, 12, 13]

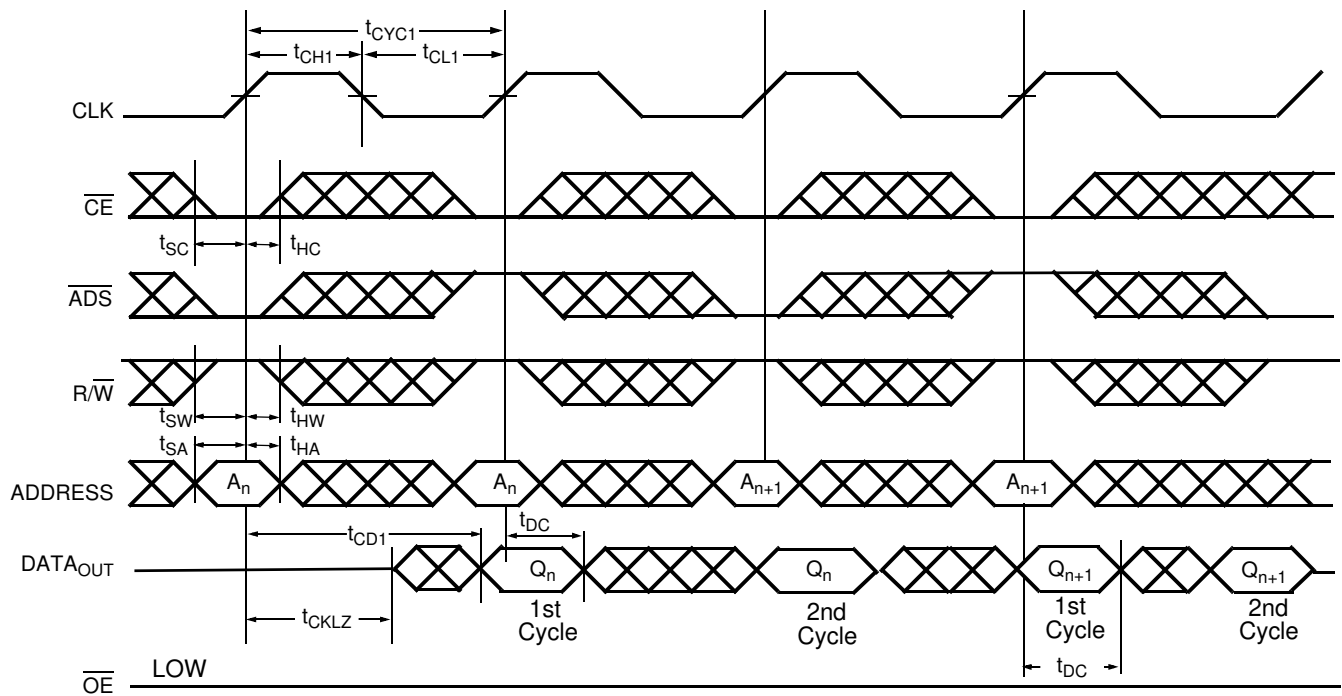
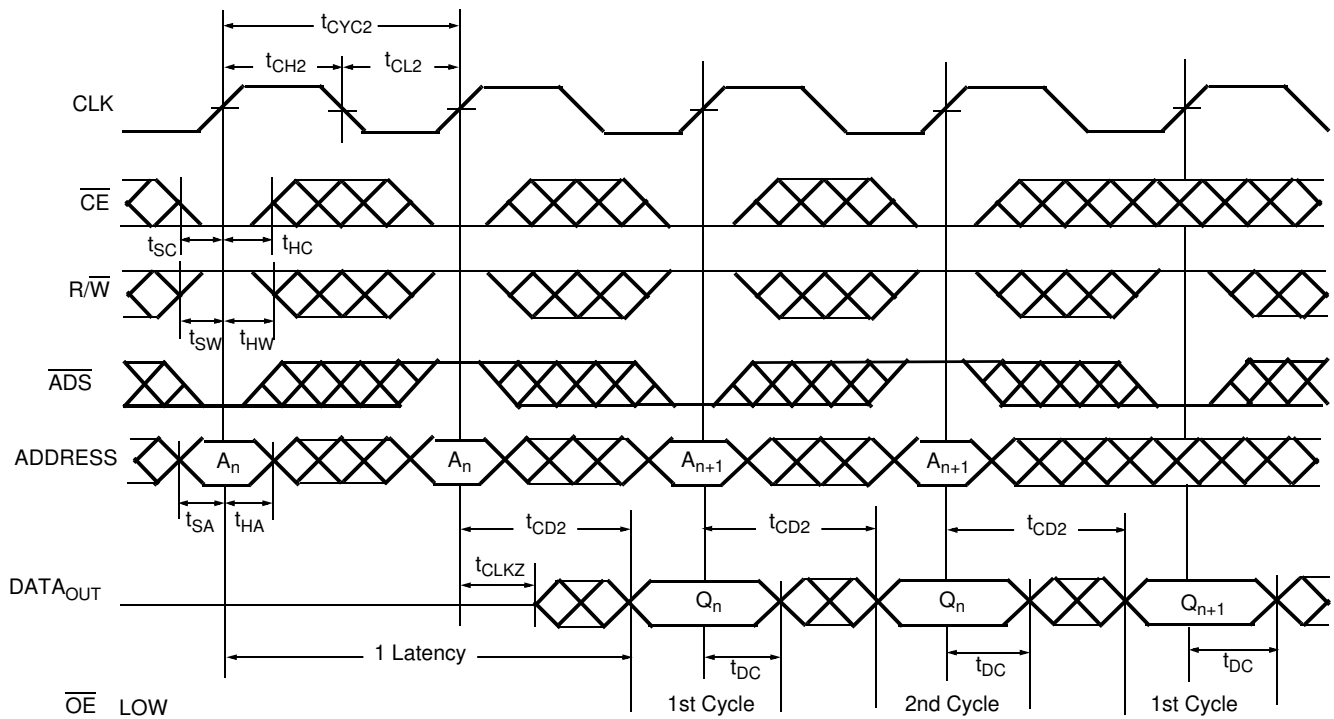
Notes:

10. \overline{OE} is asynchronously controlled; all other inputs are synchronous to the rising clock edge.
11. $ADS = V_{IL}$, $CNTEN = V_{IL}$ and $CNTRST = V_{IH}$.
12. The output is disabled (high-impedance state) by $\overline{CE} = V_{IH}$ following the next rising edge of the clock.
13. Addresses do not have to be accessed sequentially since $ADS = V_{IL}$ constantly loads the address on the rising edge of the CLK. Numbers are for reference only.

Switching Waveforms (continued)
Bus Match Read Cycle for Flow-Through Output ($\overline{FT}/\overline{PIPE} = V_{IL}$)^[10, 12, 14, 15, 16]

Bus Match Read Cycle for Pipelined Operation ($\overline{FT}/\overline{PIPE} = V_{IH}$)^[10, 12, 14, 15, 16]

Notes:

14. Timing shown is for x18 bus matching; x9 bus matching is similar with 4 cycles between address inputs.

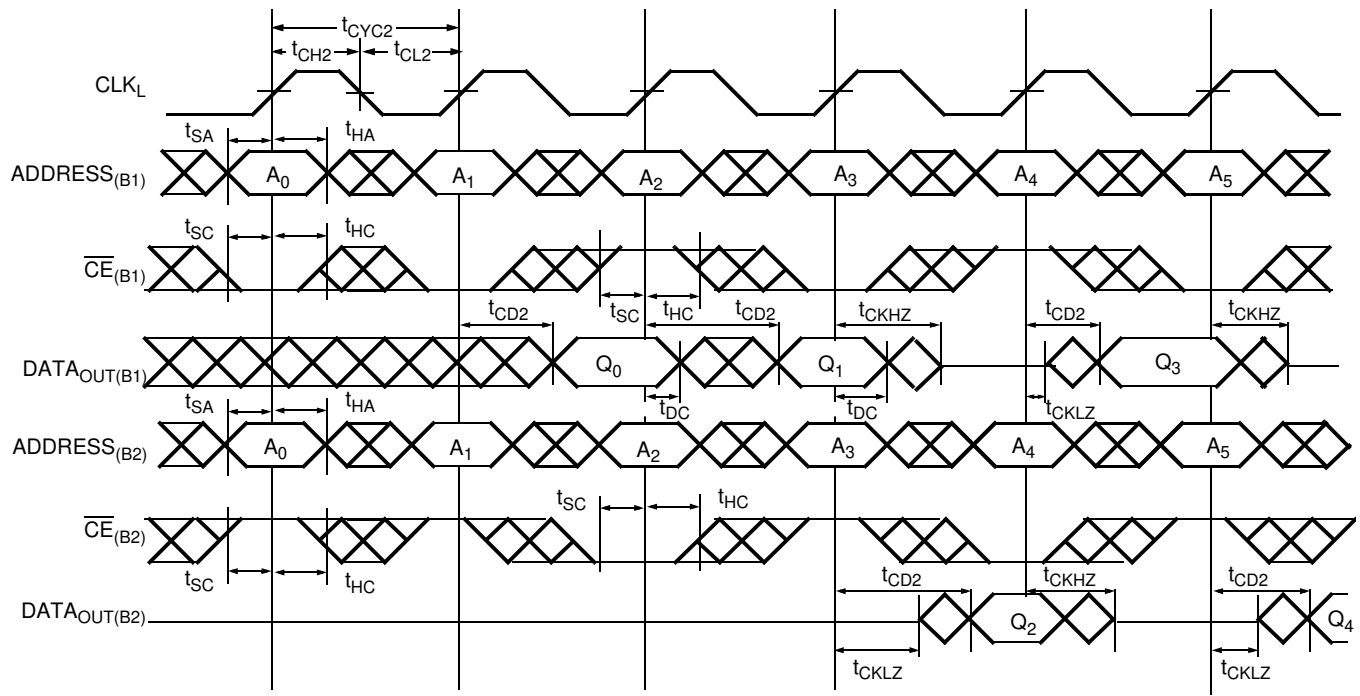
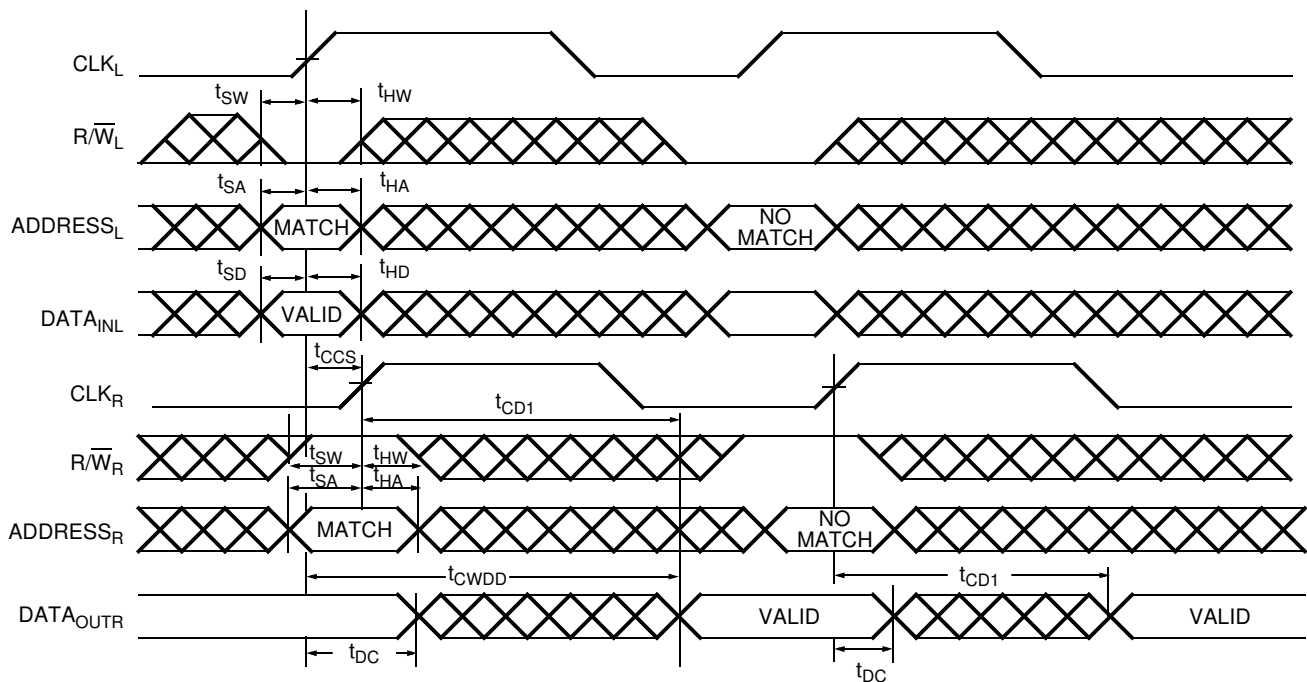
15. See table "Right Port Operation" for data output on first and subsequent cycles.

16. $CNTEN = V_{IL}$. In x9 and x18 Bus Matching Burst Mode operations (Write or Read), \overline{ADS} can toggle on the rising edge of every clock cycle or it can be at V_{IH} level all the time except when loading the initial external address (i.e. $\overline{ADS} = V_{IL}$ only required when reading or writing the first Byte or Word).

Switching Waveforms (continued)
Bank Select Pipelined Read^[17, 18]

Left Port Write to Flow-Through Right Port Read^[18, 19, 20, 21, 22]

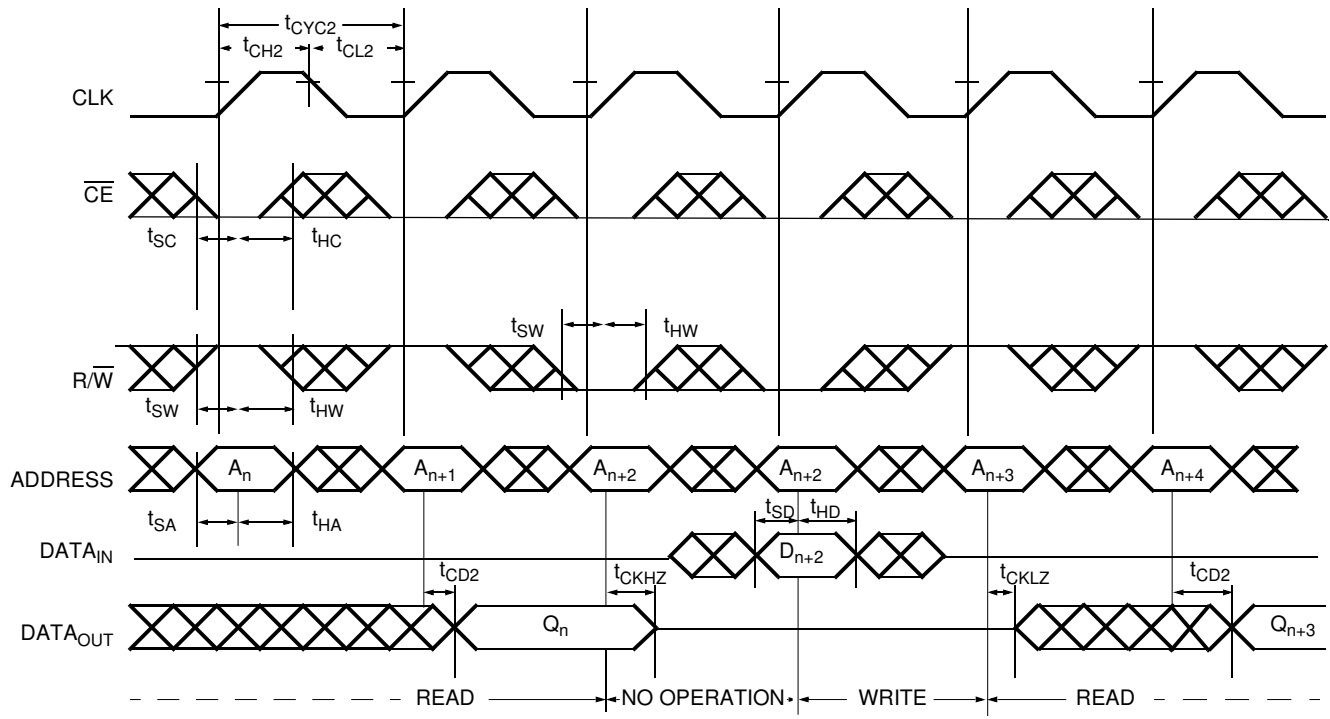
Notes:

17. In this depth expansion example, B1 represents Bank #1 and B2 is Bank #2; Each Bank consists of one Cypress dual-port device from this data sheet.
 $ADDRESS_{(B1)} = ADDRESS_{(B2)}$.
18. $B0 = B1 = B2 = B3 = BM = SIZE = ADS = CNTEN = V_{IL}$; $CNTRST = V_{IH}$.
19. The same waveforms apply for a right port write to flow-through left port read.
20. $OE = B0 = B1 = B2 = B3 = ADS = CNTEN = V_{IL}$; $CNTRST = V_{IH}$.
21. $OE = V_{IL}$ for the right port, which is being read from. $OE = V_{IH}$ for the left port, which is being written to.
22. If $t_{CCS} \leq$ maximum specified, then data from right port READ is not valid until the maximum specified for t_{CWDD} . If $t_{CCS} >$ maximum specified, then data is not valid until $t_{CCS} + t_{CD1}$ (t_{CWDD} does not apply in this case).

Switching Waveforms (continued)
Pipelined Read-to-Write-to-Read ($\overline{OE} = V_{IL}$)^[13, 23, 24, 25]

Notes:

23. Output state (HIGH, LOW, or High-Impedance) is determined by the previous cycle control signals.

24. $\overline{CE} = \overline{ADS} = \overline{CNTEN} = V_{IL}$; $\overline{CNTST} = V_{IH}$.

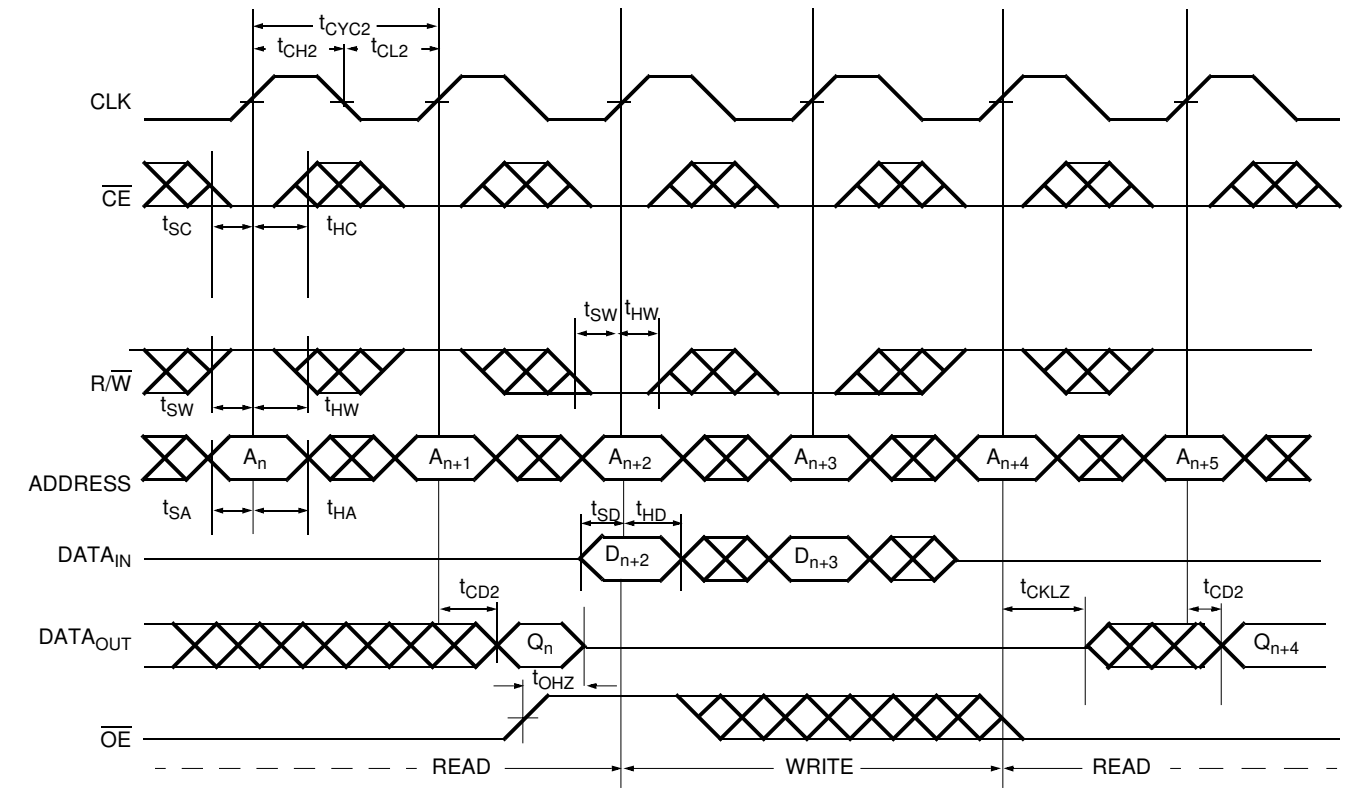
25. During "No Operation," data in memory at the selected address may be corrupted and should be rewritten to ensure data integrity.

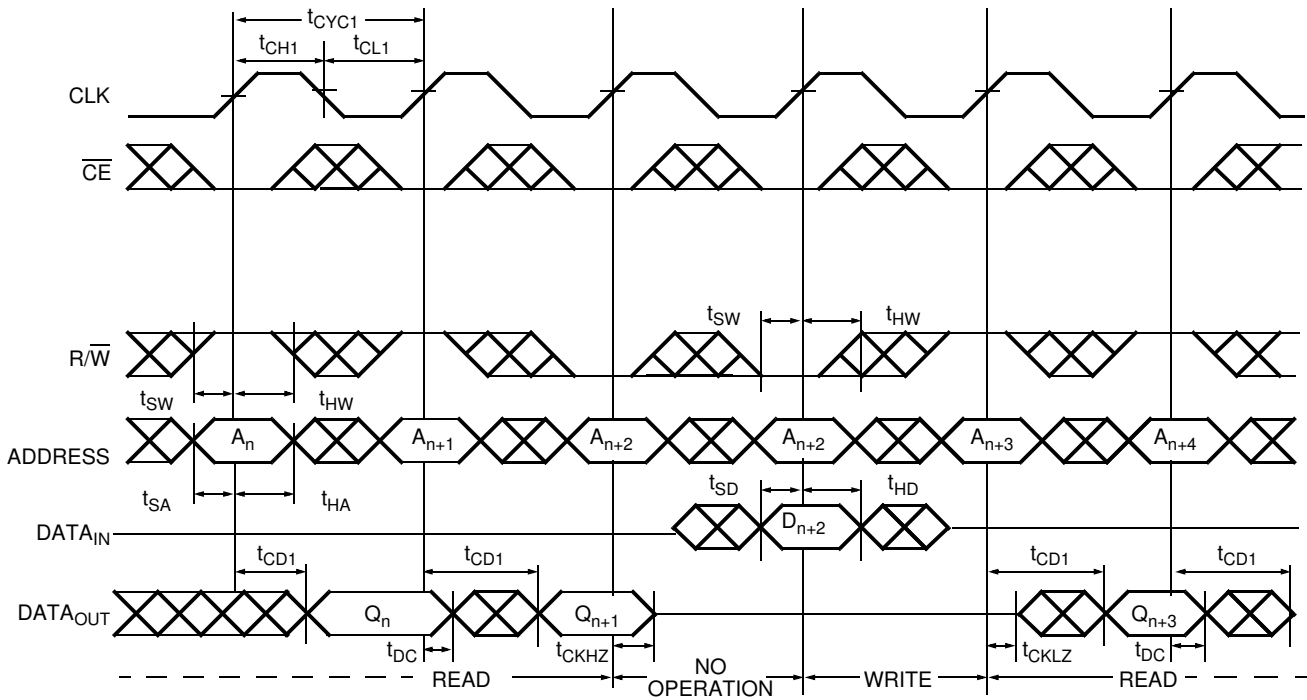
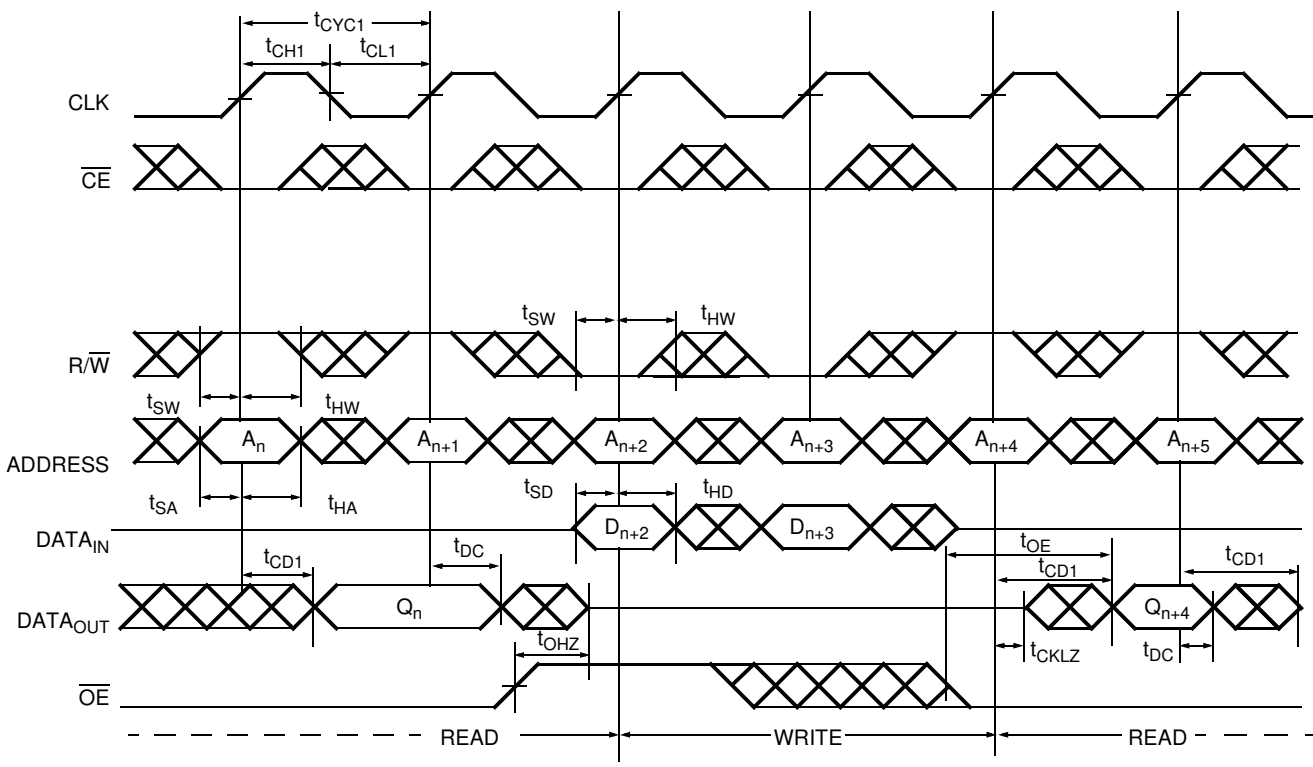
Switching Waveforms (continued)
Pipelined Read-to-Write-to-Read (\overline{OE} Controlled)^[11, 23, 24, 25]

Switching Waveforms (continued)
Flow-Through Read-to-Write-to-Read ($\overline{OE} = V_{IL}$)^[11, 13, 14, 15, 24, 25]

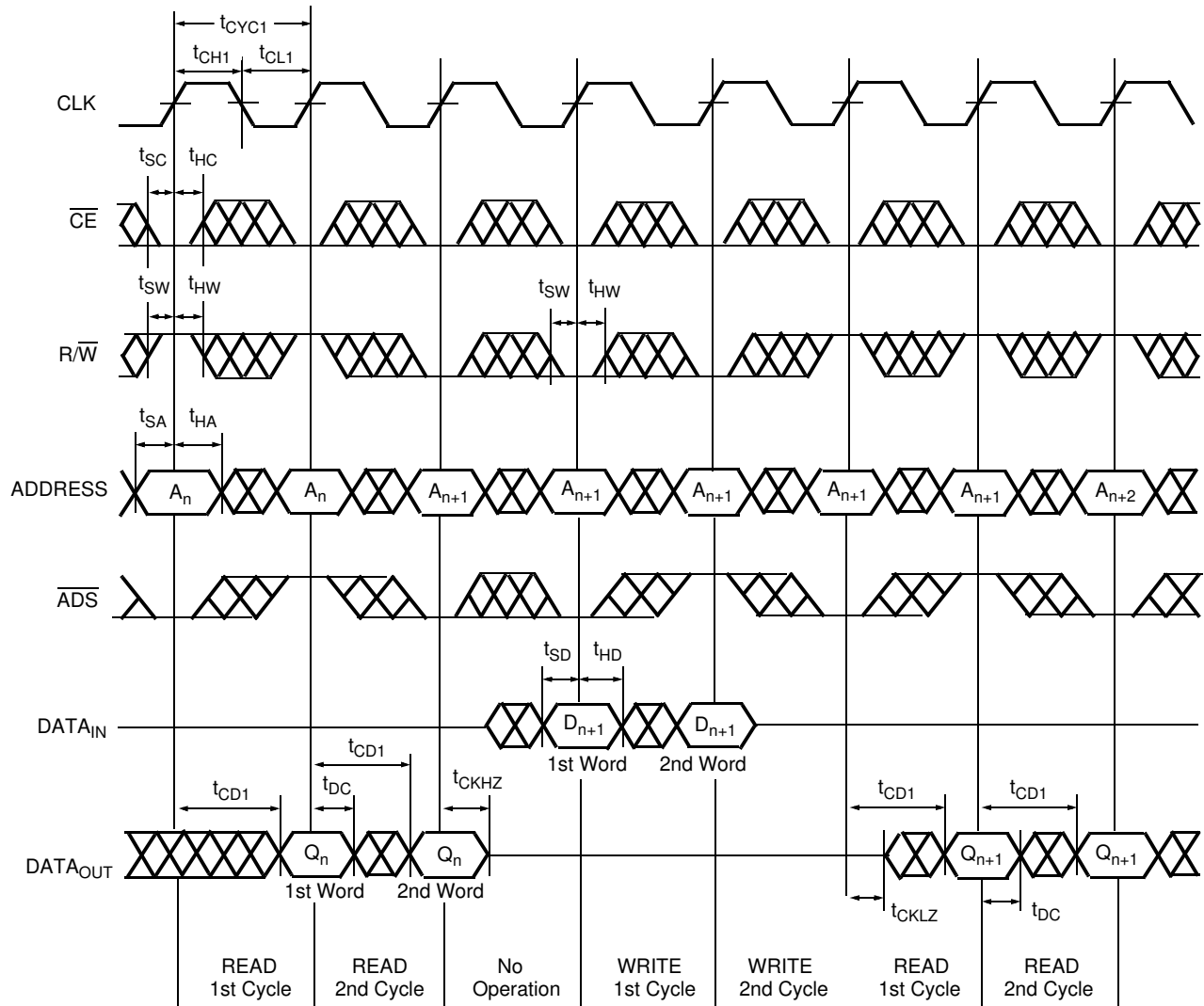
Flow-Through Read-to-Write-to-Read (\overline{OE} Controlled)^[11, 13, 23, 24, 25]

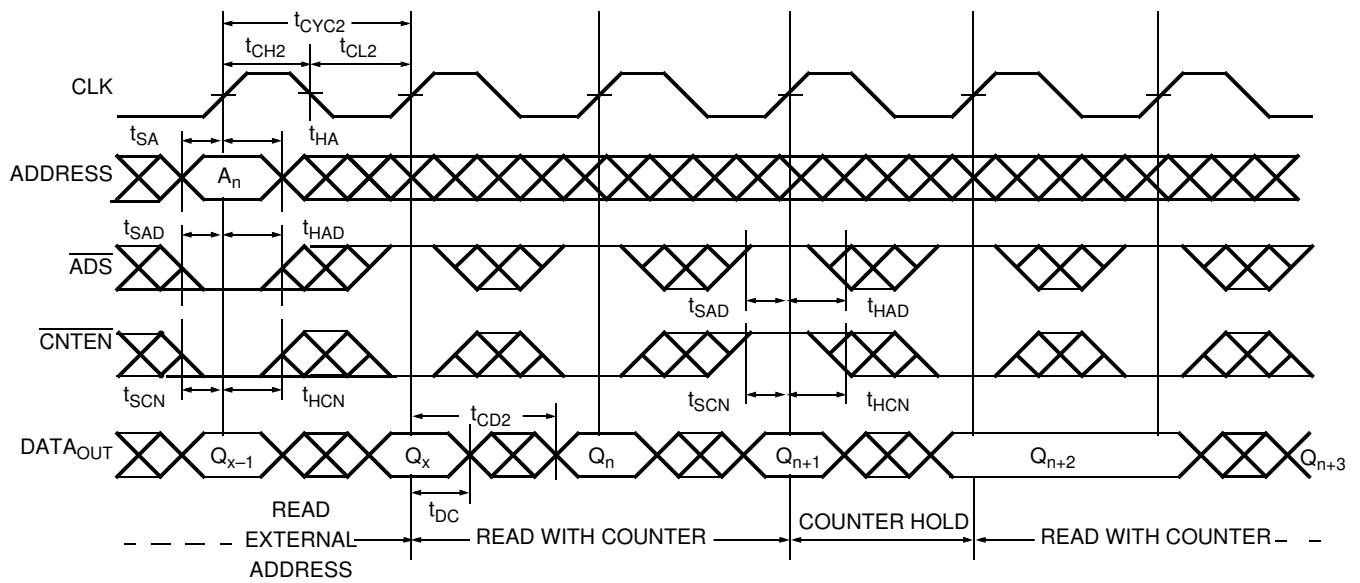
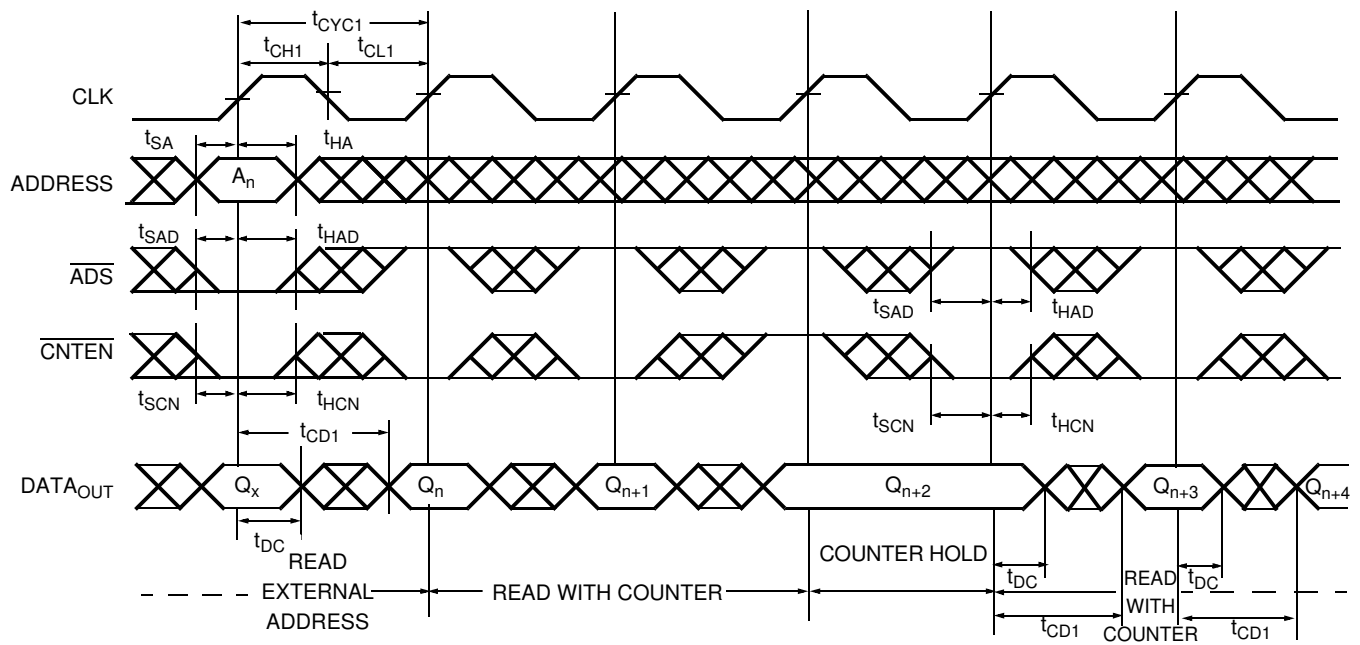
Switching Waveforms (continued)
Bus Match Flow-Through Read-to-Write-to-Read ($\overline{OE} = V_{IL}$)^[11, 14, 15, 16, 24, 25, 26]

Switching Waveforms (continued)
Pipelined Read with Address Counter Advance^[27]

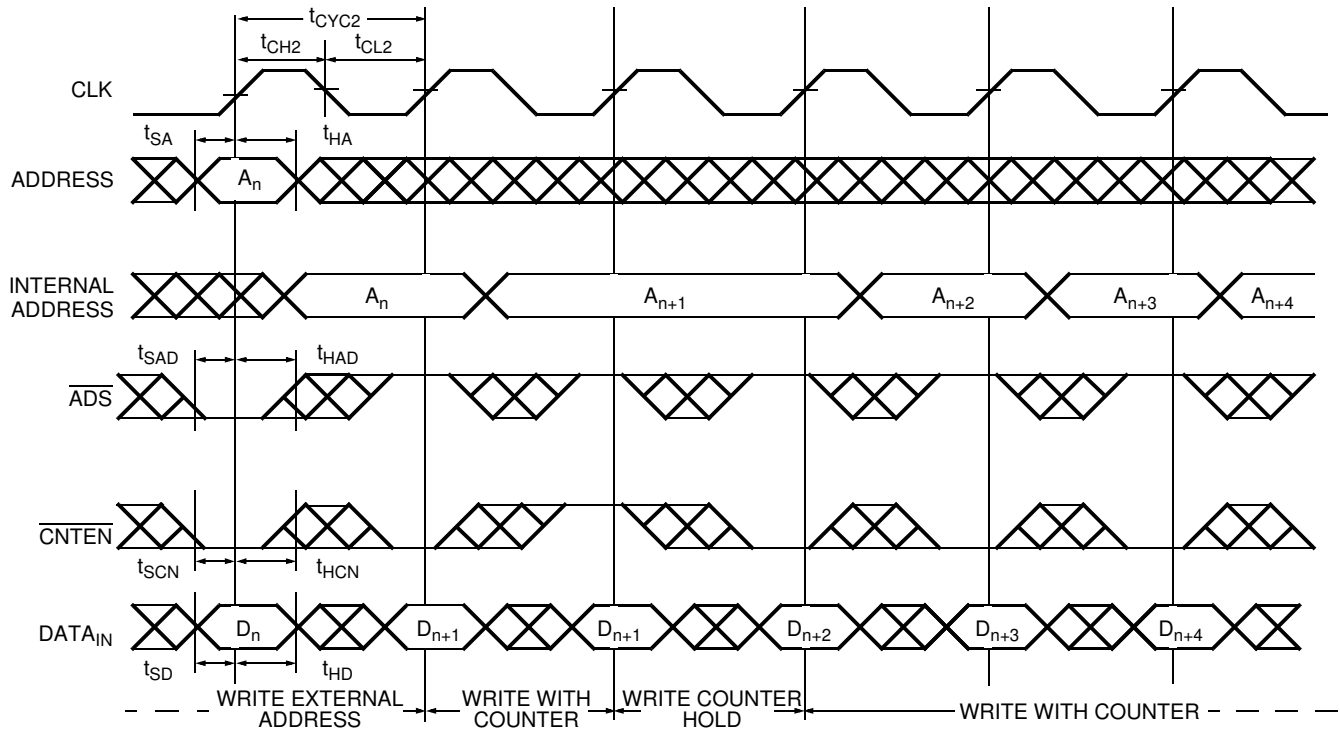
Flow-Through Read with Address Counter Advance^[27]

Note:
 27. $\overline{CE} = \overline{OE} = V_{IL}$; $R/\overline{W} = \overline{CNTNST} = V_{IH}$.

Switching Waveforms (continued)
Write with Address Counter Advance (Flow-Through or Pipelined Outputs)^[28, 29]

Notes:

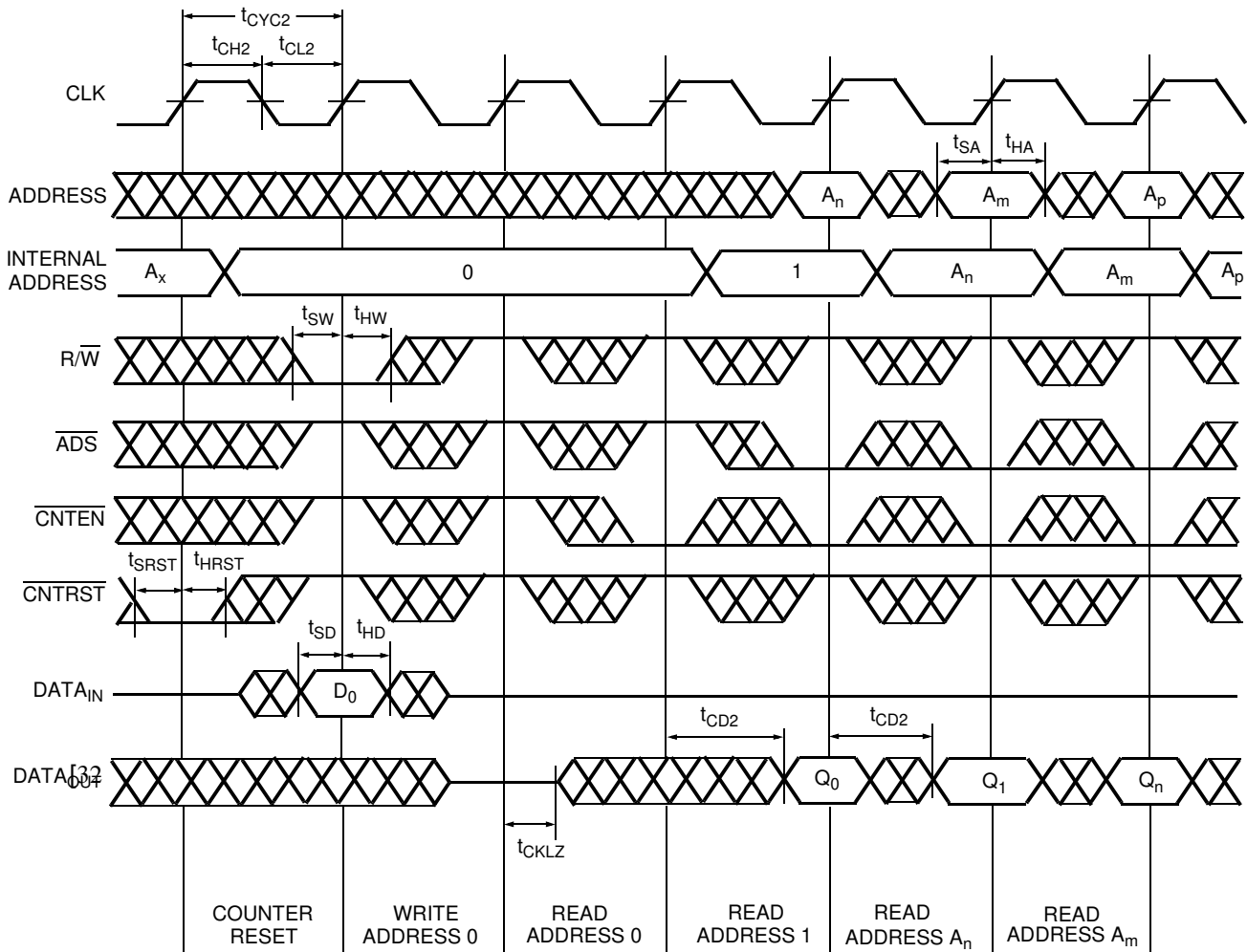
28. $\overline{CE} = \overline{B0} = \overline{B1} = \overline{B2} = \overline{B3} = R/\overline{W} = V_{IL}$; $\overline{CNTRST} = V_{IH}$.

29. The "Internal Address" is equal to the "External Address" when $\overline{ADS} = \overline{CNTEN} = V_{IL}$ and $\overline{CNTRST} = V_{IH}$.

Switching Waveforms (continued)
Counter Reset (Pipelined Outputs)^[11, 23, 30, 31, 32]

Notes:

30. $\overline{CE} = \overline{B0} = \overline{B1} = \overline{B2} = \overline{B3} = V_{IL}$.

31. No dead cycle exists during counter reset. A READ or WRITE cycle may be coincidental with the counter reset.

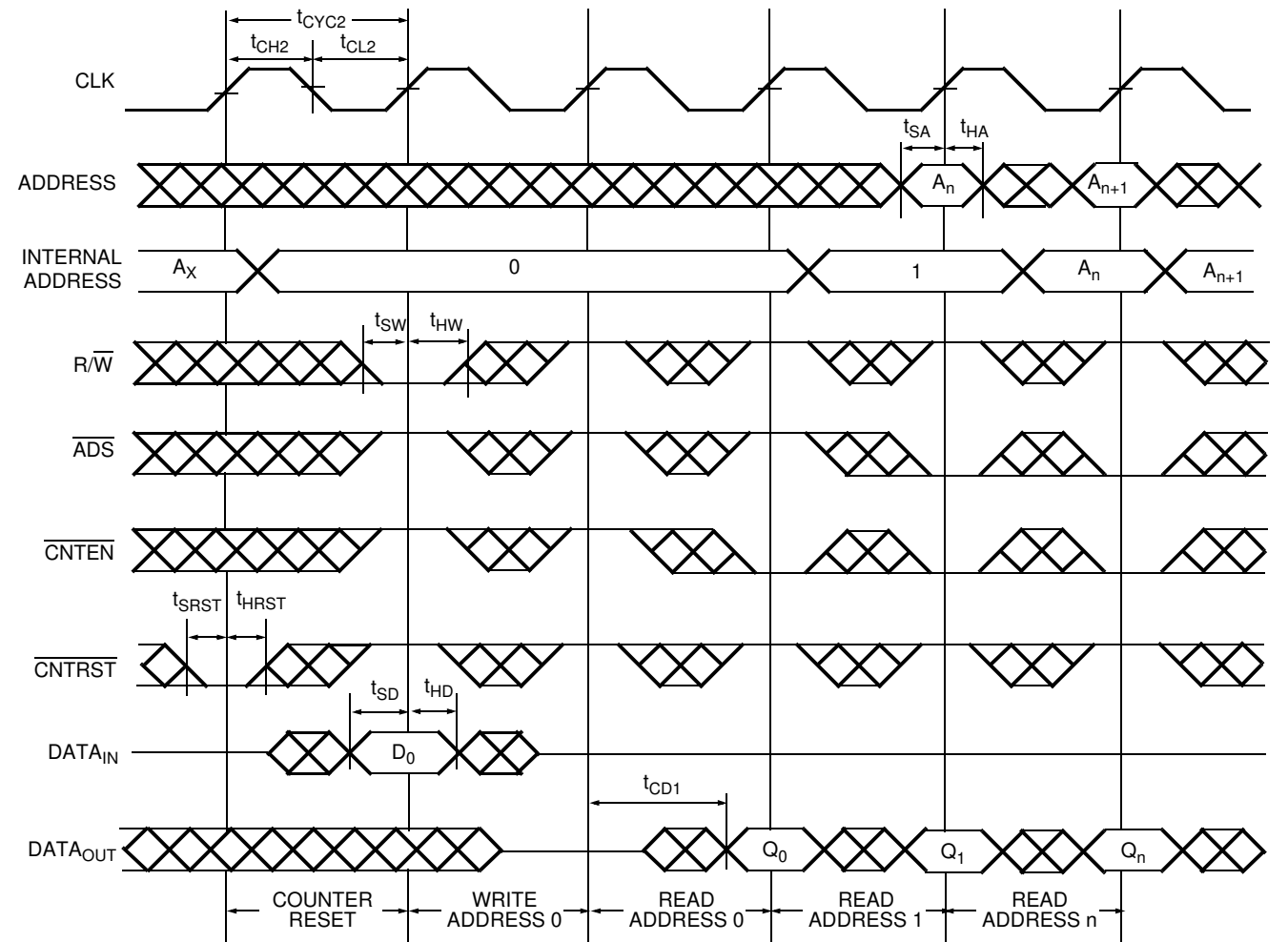
32. Output state (HIGH, LOW, or High-Impedance) is determined by the previous cycle control signals. Ideally, DATA_{OUT} should be in the High-Impedance state during a valid WRITE cycle.

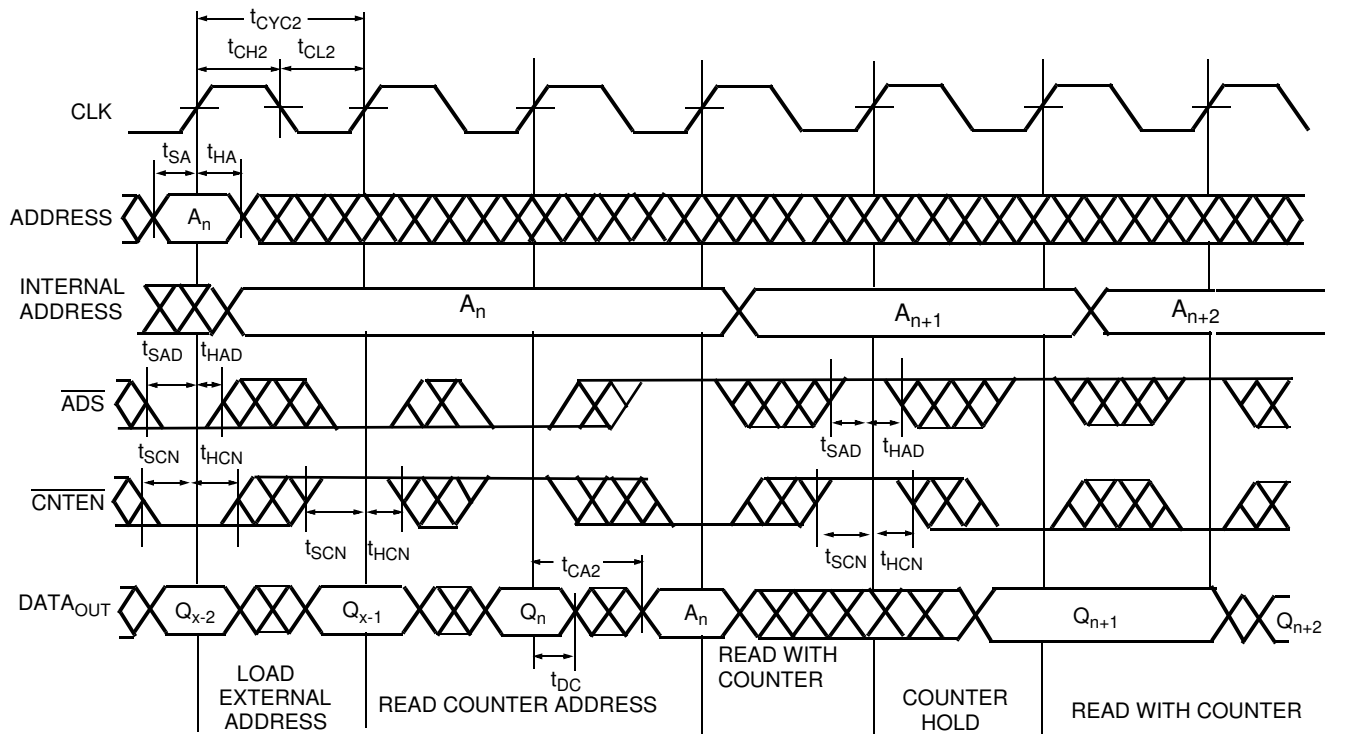
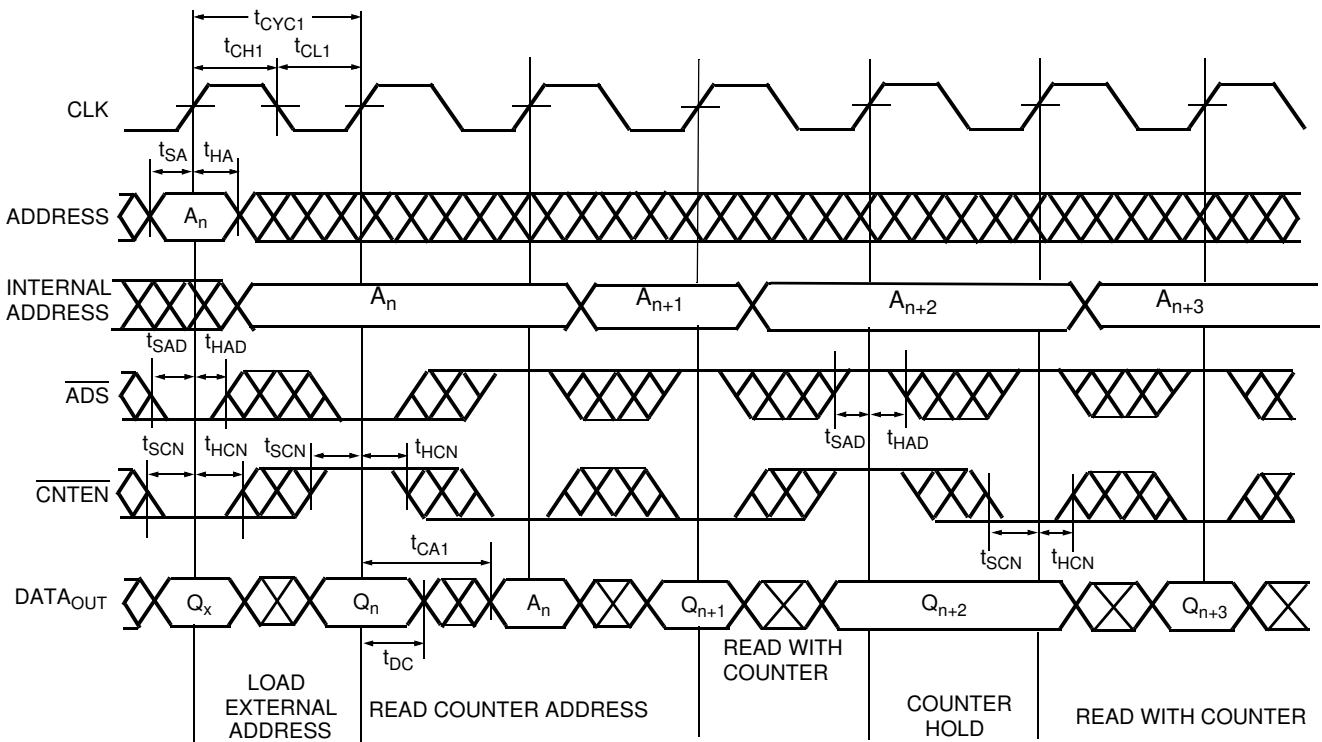
Switching Waveforms (continued)
Counter Reset (Flow-Through Outputs)^[23, 25, 30, 31, 32]

Switching Waveforms (continued)
Pipelined Read of State of Address Counter [33, 34, 35]

Flow-Through Read of State of Address Counter [33, 34, 36]

Notes:



33. $\overline{CE} = \overline{OE} = V_{IL}$; $R/\overline{W} = \overline{CNRST} = V_{IH}$.

34. When reading ADDRESS_{OUT} in x9 Bus Match mode, readout of A_N is extended by 1 cycle.





35. For Pipelined address counter read, signals from address counter operation table must be valid for 2 consecutive cycles for x36 and x18 mode and for 3 consecutive cycles for x9 mode.

36. For flow-through address counter read, signals from address counter operation table must be valid for consecutive cycles for x36.

Read/Write and Enable Operation^[37, 38, 39]

Inputs				Outputs	Operation
OE	CLK	CE	R/W	I/O ₀ -I/O ₃₅	
X		H	X	High-Z	Deselected ^[40]
X		L	L	D _{IN}	Write
L		L	H	D _{OUT}	Read ^[40]
H	X	L	X	High-Z	Outputs Disabled

Address Counter Control Operation^[37, 41]

Address	Previous Address	CLK	OE	R/W	ADS	CNTEN	CNTRST	Mode	Operation
X	X		X	X	X	X	L	Reset	Counter Reset
A _n	X		X	X	L	L	H	Load	Address Load into Counter
A _n	A _n		L	H	L	H	H	Hold + Read	External Address Blocked - Counter Address Readout
X	A _n		X	X	H	H	H	Hold	External Address Blocked - Counter Disabled
X	A _n		X	X	H	L	H	Increment	Counter Increment

Notes:

37. "X" = "Don't Care." "H" = V_{IH}, "L" = V_{IL}.

38. ADS, CNTEN, CNTRST = "Don't Care."

39. OE is an asynchronous input signal.

40. When CE changes state in the pipelined mode, deselection and read happen in the following clock cycle.

41. Counter operation is independent of CE.

Right Port Configuration^[26, 42]

BM	SIZE	Configuration	I/O Pins used
0	0	x36	I/O _{0R-35R}
1	0	x18	I/O _{0R-17R}
1	1	x9	I/O _{0R-8R}

Right Port Operation^[43]

Configuration	BE	Data on 1st Cycle	Data on 2nd Cycle	Data on 3rd Cycle	Data on 4th Cycle
x18	0	DQ _{0R-17R}	DQ _{18R-35R}	-	-
x18	1	DQ _{18R-35R}	DQ _{0R-17R}	-	-
x9	0	DQ _{0R-8R}	DQ _{9R-17R}	DQ _{18R-26R}	DQ _{27R-35R}
x9	1	DQ _{27R-35R}	DQ _{18R-26R}	DQ _{9R-17R}	DQ _{0R-8R}

Readout of Internal Address Counter^[44]

Configuration	Address on 1st Cycle	I/O Pins used on 1st Cycle	Address on 2nd Cycle	I/O Pins used on 2nd Cycle
Left Port x36	A _{0L-14L}	I/O _{3L-17L}	-	-
Right Port x36	A _{0R-14R}	I/O _{3R-17R}	-	-
Right Port x18	WA, A _{0R-14R}	I/O _{2R-17R}	-	-
Right Port x9	A _{6R-14R}	I/O _{0R-8R}	BA, WA, A _{0R-5R}	I/O _{1R-8R}

Left Port Operation

Control Pin	Effect
$\overline{B0}$	I/O ₀₋₈ Byte Control
$\overline{B1}$	I/O ₉₋₁₇ Byte Control
$\overline{B2}$	I/O ₁₈₋₂₆ Byte Control
$\overline{B3}$	I/O ₂₇₋₃₅ Byte Control

Notes:

42. In x36 mode, BE input is a "Don't Care."

43. DQ represents data output of the chip.

44. x18 and x9 configuration apply to right port only.

Counter Operation

The CY7C09569V/09579V Dual-Port RAM (DPRAM) contains on-chip address counters (one for each port) for the synchronous members of the product family. Besides the main x36 format, the right port allows bus matching (x18 or x9, user-selectable). An internal sub-counter provides the extra addresses required to sequence out the 36-bit word in 18-bit or 9-bit increments. The sub-counter counts up in the “Little Endian” mode, and counts down if the user has chosen the “Big Endian” mode. The address counter is required to be in increment mode in order for the sub-counter to sequence out the second word (in x18 mode) or the remaining three bytes (in x9 mode).

For a x36 format (the only active format on the left port), each address counter in the CY7C09579V uses addresses (A_{0-14}).

For the right port (allowing for the bus-matching feature), a maximum of two address bits (out of a 2-bit sub-counter) are added.

1. $\overline{ADS}_{L/R}$ (pin #23/86) is a port's address strobe, allowing the loading of that port's burst counters if the corresponding $\overline{CNTEN}_{L/R}$ pin is active as well.
2. $\overline{CNTEN}_{L/R}$ (pin #25/84) is a port's count enable, provided to stall the operation of the address input and utilize the internal address generated by the internal counter for fast interleaved memory applications; when asserted, the address counter will increment on each positive transition of that port's clock signal.
3. $\overline{CNTRST}_{L/R}$ (pin #24/85) is a port's burst counter reset.

A new read-back (Hold+Read Mode) feature has been added, which is different between the left and right port due to the bus matching feature provided only for the right port. In read-back mode the internal address of the counter will be read from the data I/Os as shown in *Figure 1*.

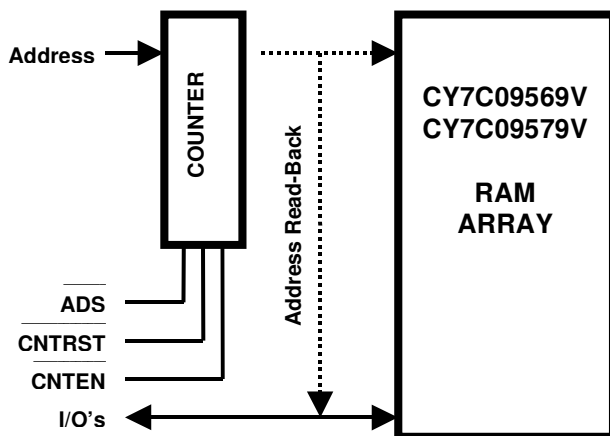

Figure 1. Counter Operation Diagram

Bus Match Operation

The right port of the CY7C09569V/09579V 16K/32Kx36 dual-port SRAM can be configured in a 36-bit long-word, 18-bit

Note:

45. Even though a logic level applied to a “Don't Care” input will not change the logical operation of the dual-port, inputs that are temporarily a “Don't Care” (along with unused inputs) must not be allowed to float. They must be forced either HIGH or LOW.

word, or 9-bit byte format for data I/O. The data lines are divided into four lanes, each consisting of 9 bits (byte-size data lines).

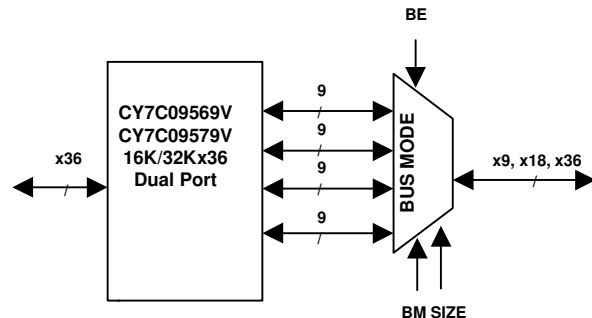

Figure 2. Bus Match Operation Diagram

The Bus Match Select (BM) pin works with Bus Size Select (SIZE) and Big Endian Select (BE) to select the bus width (long-word, word, or byte) and data sequencing arrangement for the right port of the dual-port device. A logic “0” applied to both the Bus Match Select (BM) pin and to the Bus Size Select (SIZE) pin will select long-word (36-bit) operation. A logic “1” level applied to the Bus Match Select (BM) pin will enable whether byte or word bus width operation on the right port I/Os depending on the logic level applied to the SIZE pin. The level of Bus Match Select (BM) must be static throughout normal device operation.

The Bus Size Select (SIZE) pin selects either a byte or word data arrangement on the right port when the Bus Match Select (BM) pin is HIGH. A logic “1” on the SIZE pin when the BM pin is HIGH selects a byte bus (9-bit) data arrangement. A logic “0” on the SIZE pin when the BM pin is HIGH selects a word bus (18-bit) data arrangement. The level of the Bus Size Select (SIZE) must also be static throughout normal device operation.

The Big Endian Select (BE) pin is a multiple-function pin during word or byte bus selection ($BM = 1$). BE is used in Big Endian Select mode to determine the order by which bytes (or words) of data are transferred through the right data port. A logic “0” on the BE pin will select Little Endian data sequencing arrangement and a logic “1” on the BE pin will select a Big Endian data sequencing arrangement. Under these circumstances, the level on the BE pin should be static throughout dual-port operation.

Long-Word (36-bit) Operation

Bus Match Select (BM) and Bus Size Select (SIZE) set to a logic “0” will enable standard cycle long-word (36-bit) operation. In this mode, the right port's I/O operates essentially in an identical fashion to the left port of the dual-port SRAM. However no Byte Select control is available. All 36 bits of the long-word are shifted into and out of the right port's I/O buffer stages. All read and write timing parameters may be identical with respect to the two data ports. When the right port is configured for a long-word size, Big-Endian Select (BE) pin has no application and their inputs are “Don't Care”^[45] for the external user.

Word (18-bit) Operation

Word (18-bit) bus sizing operation is enabled when Bus Match Select (BM) is set to a logic "1" and the Bus Size Select (SIZE) pin is set to a logic "0." In this mode, 18 bits of data are ported through I/O_{0R-17R}. The level applied to the Big Endian (BE) pin determines the right port data I/O sequencing order (Big Endian or Little Endian).

During word (18-bit) bus size operation, a logic LOW applied to the BE pin will select Little Endian operation. In this case, the least significant data word is read from the right port first or written to the right port first. A logic "1" on the BE pin during word (18-bit) bus size operation will select Big Endian operation resulting in the most significant data word being transferred through the right port first. Internally, the data will be stored in the appropriate 36-bit LSB or MSB I/O memory location. Device operation requires a minimum of two clock cycles to read or write during word (18-bit) bus size operation. An internal sub-counter automatically increments the right port multiplexer control when Little or Big Endian operation is in effect.

Byte (9-bit) Operation

Byte (9-bit) bus sizing operation is enabled when Bus Match Select (BM) is set to a logic "1" and the Bus Size Select (SIZE) pin is set to a logic "1." In this mode, 9 bits of data are ported through I/O_{0R-8R}.

Big Endian and Little Endian data sequencing is available for dual-port operation. The level applied to the Big Endian pin (BE) under these circumstances will determine the right port data I/O sequencing order (Big or Little Endian). A logic LOW applied to the BE pin during byte (9-bit) bus size operation will select Little Endian operation. In this case, the least significant data byte is read from the right port first or written to the right port first. A logic "1" on the BE pin during byte (9-bit) bus size operation will select Big Endian operation resulting in the most significant data word to be transferred through the right port first. Internally, the data will be stored in the appropriate 36-bit LSB or MSB I/O memory location. Device operation requires a minimum of four clock cycles to read or write during byte (9-bit) bus size operation. An internal sub-counter automatically increments the right port multiplexer control when Little or Big Endian operation is in effect. When transferring data in byte (9-bit) bus match format, the unused I/O pins (I/O_{9RQ-35R}) are three-stated.

Ordering Information
16K x36 3.3V Synchronous Dual-Port SRAM

Speed (MHz)	Ordering Code	Package Name	Package Type	Operating Range
100	CY7C09569V-100AC	A144	144-Pin Thin Quad Flat Pack	Commercial
	CY7C09569V-100AXC	A144	144-Pin Pb-Free Thin Quad Flat Pack	Commercial
	CY7C09569V-100BBC	BB172	172-Ball Ball Grid Array (BGA)	Commercial
83	CY7C09569V-83AC	A144	144-Pin Thin Quad Flat Pack	Commercial
	CY7C09569V-83AXC	A144	144-Pin Pb-Free Thin Quad Flat Pack	Commercial
	CY7C09569V-83BBC	BB172	172-Ball Ball Grid Array (BGA)	Commercial
67	CY7C09569V-67AC	A144	144-Pin Thin Quad Flat Pack	Commercial
	CY7C09569V-67BBC	BB172	172-Ball Ball Grid Array (BGA)	Commercial

32K x36 3.3V Synchronous Dual-Port SRAM

Speed (MHz)	Ordering Code	Package Name	Package Type	Operating Range
100	CY7C09579V-100AC	A144	144-Pin Thin Quad Flat Pack	Commercial
	CY7C09579V-100AXC	A144	144-Pin Pb-Free Thin Quad Flat Pack	Commercial
	CY7C09579V-100BBC	BB172	172-Ball Ball Grid Array (BGA)	Commercial
83	CY7C09579V-83AC	A144	144-Pin Thin Quad Flat Pack	Commercial
	CY7C09579V-83AXC	A144	144-Pin Pb-Free Thin Quad Flat Pack	Commercial
	CY7C09579V-83AI	A144	144-Pin Thin Quad Flat Pack	Industrial
	CY7C09579V-83AXI	A144	144-Pin Pb-Free Thin Quad Flat Pack	Industrial
	CY7C09579V-83BBC	BB172	172-Ball Ball Grid Array (BGA)	Commercial
	CY7C09579V-83BBI	BB172	172-Ball Ball Grid Array (BGA)	Industrial
67	CY7C09579V-67AC	A144	144-Pin Thin Quad Flat Pack	Commercial
	CY7C09579V-67BBC	BB172	172-Ball Ball Grid Array (BGA)	Commercial

Package Diagrams

144-Pin Plastic Thin Quad Flat Pack (TQFP) A144
144-Pin Pb-Free Plastic Thin Quad Flat Pack (TQFP) A144

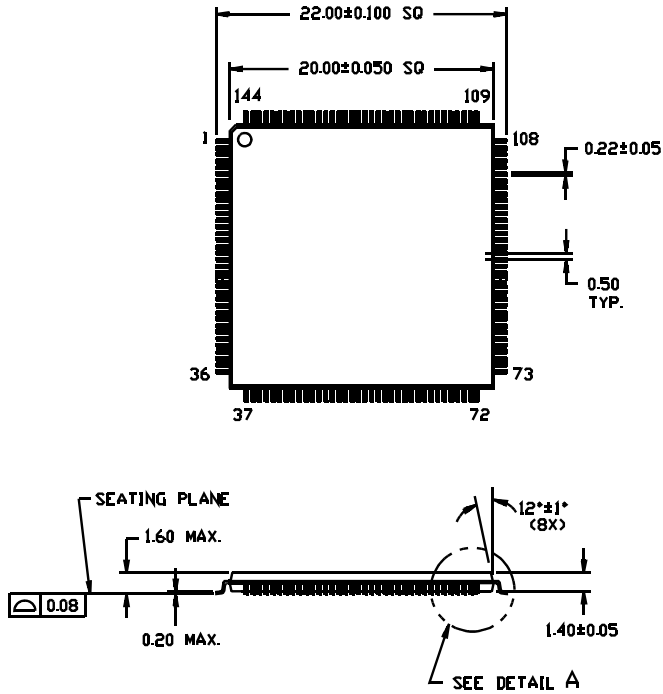

DIMENSIONS ARE IN MILLIMETERS.

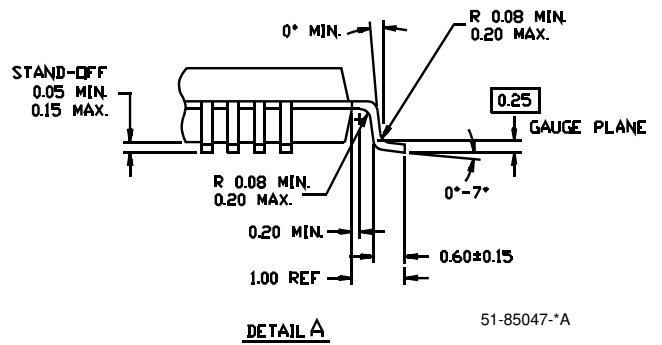

Package Diagrams (continued)

172-Ball FBGA (15 x 15 x 1.25 mm) BB172

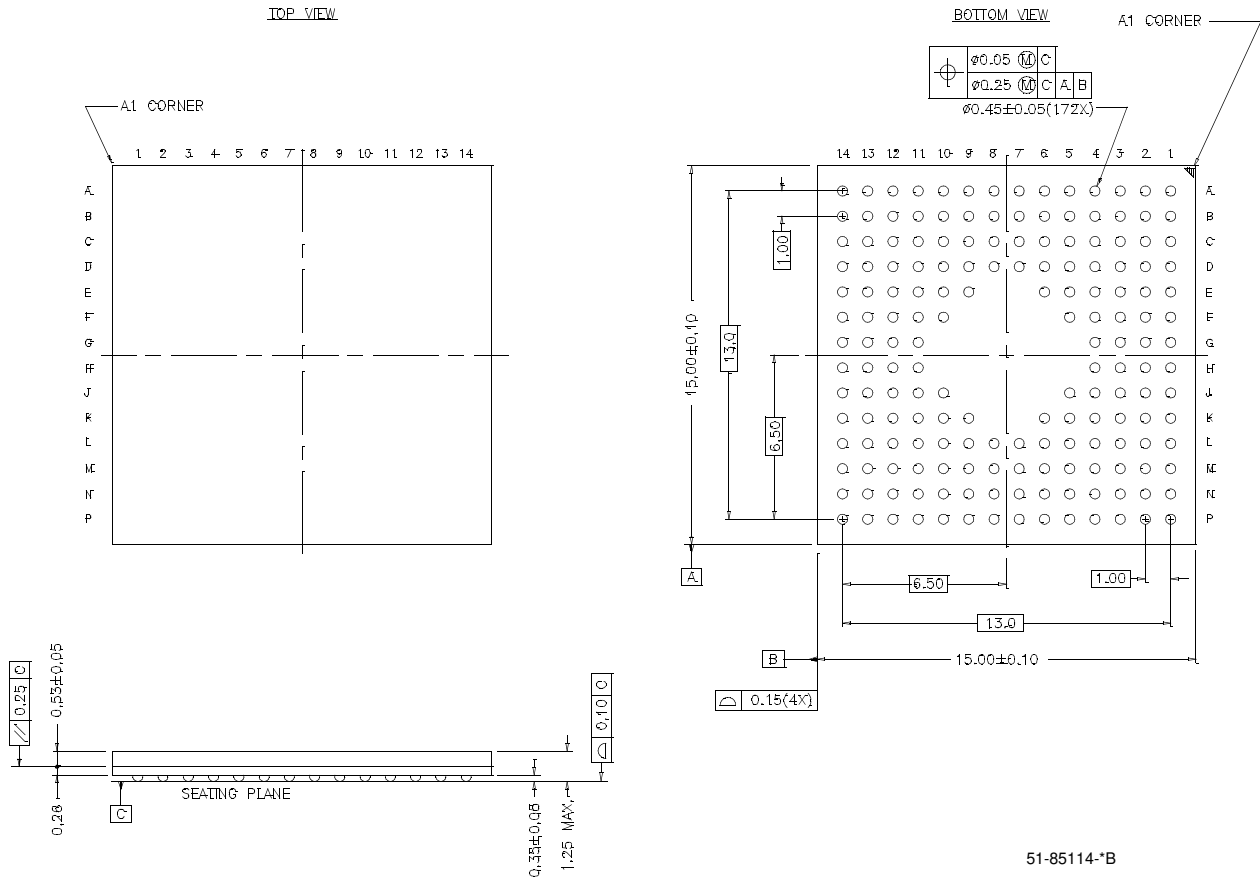

51-85114-*B

FLex36 is a trademark of Cypress Semiconductor Corporation. All products and company names mentioned in this document may be the trademarks of their respective holders.



Document History Page

Document Title: CY7C09569V/CY7C09579V 3.3 16K/ 32K x 36 FLEx36™ Synchronous Dual-Port Static RAM				
Document Number: 38-06054				
REV.	ECN NO.	Issue Date	Orig. of Change	Description of Change
**	110213	12/16/01	SZV	Change from Spec number: 38-00743 to 38-06054
*A	122304	12/27/02	RBI	Power up requirements added to Maximum Ratings Information
*B	349775	See ECN	RUY	Added Pb-Free Information