

Product Document



Datasheet

DS000501

NanEye

Miniature Camera Module

v8-00 • 2021-Nov-25

Content Guide

1	General Description	3	8.1	Detailed Register Description	23
1.1	Key Benefits & Features.....	3	9	Application Information.....	24
1.2	Applications	4	9.1	Recommended LVDS Receiver	
1.3	Block Diagram	4		Electronics	24
2	Ordering Information	5	9.2	Application Notes.....	25
3	Pin Assignment	6	9.3	PCB Layout.....	25
3.1	Pin Diagram.....	6	10	Package Drawings & Markings... 	26
3.2	Pin Description	7	11	Tape & Reel Information.....	30
4	Absolute Maximum Ratings	8	12	Appendix	32
5	Electrical Characteristics.....	9	12.1	Evaluation System.....	32
6	Typical Operating		13	Revision Information	33
	Characteristics	12	14	Legal Information.....	34
7	Functional Description.....	14			
7.1	Sensor Architecture	14			
7.2	Driving the NanEye	16			
7.3	Matrix Readout	17			
7.4	Serial Interface	18			
7.5	Sensor Programming	21			
8	Register Description	23			

1 General Description

NanEye is a miniature sized image sensor vision applications where size is a critical factor. The ability of the camera head to drive a signal through long cables makes this the ideal component for minimal diameter endoscopes.

With a footprint of a just 1 mm x 1 mm, it features a 249x250 resolution with a high sensitive 3-micron rolling shutter pixel, with large full well capacitance. The sensor has been specially designed for medical endoscopic applications where high SNR is mandatory. The sensor has a high frame rate of about 43 to 62 fps to permit SNR enhancement and a smooth, low delay display over a wide range of standard interfaces.

The sensor includes a 10-bit ADC and a bit serial LVDS data interface. The sensor is able to drive the signal through a cable length of up to 3 m.

The data line is semi duplex, such that configuration can be communicated to the sensor in the frame brake.

The exposure time, dark level and analogue gain can be programmed over the serial configuration interface.

1.1 Key Benefits & Features

The benefits and features of NanEye, Miniature Camera Module are listed below:

Figure 1:
Added Value of Using NanEye

Benefits	Features
Designed for the toughest confined space requirements	Footprint of 1 mmx1 mm with 4 contact pads
Smooth and accurate image	Frame rate of 43-62fps @ 249x250 resolution
Reach further	Possible to drive a signal through an endoscope of up to 3 m
Affordable single use application	Designed with a focus on cost efficiency
Envision the unseen	3-micron high sensitive pixel with 62 k pixel resolution

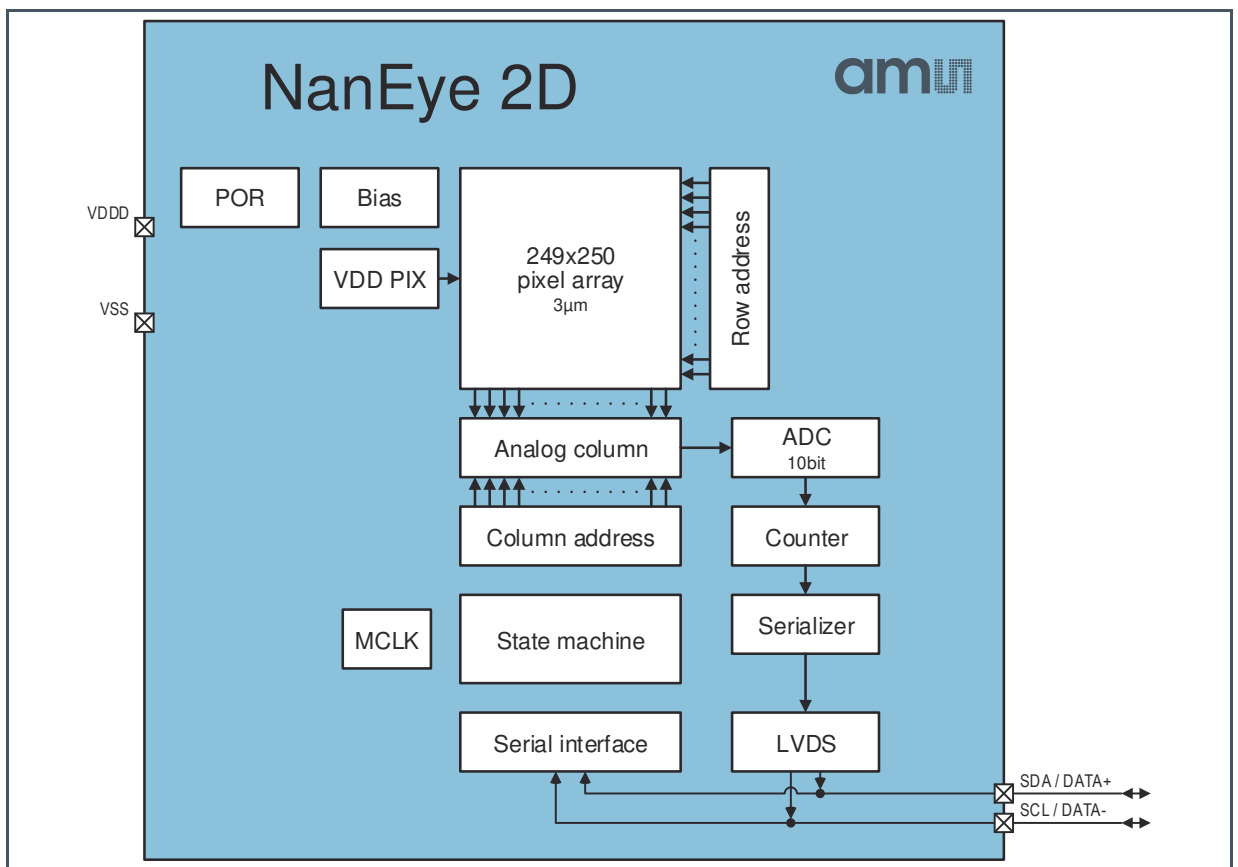
1.2 Applications

- Medical Applications
 - Endoscopy
 - Intraoral Scanning
- Industrial Applications
 - Industrial endoscopy
 - Robotics
 - IoT (Internet of Things)
- Wearable Devices
 - Eye tracking
 - Virtual / Augmented reality
 - Gesture recognition

1.3 Block Diagram

The functional blocks of this device are shown below:

Figure 2 :
Functional Blocks of NanEye



2 Ordering Information

Ordering Code	Package	Optics	Delivery Form
CHIP Only Version			
NE2D_CHIP_B&W_SGA	SGA	No lens	Tray
NE2D_CHIP_RGB_SGA	SGA	No lens	Tray
RGB Version			
NE2D_RGB_V90F2.7_2m	Cabled module	FOV90°; F2.7	Spool
NE2D_RGB_V90F4.0_2m	Cabled module	FOV90°; F4.0	Spool
NE2D_RGB_V120F2.8_2m	Cabled module	FOV120°; F2.8	Spool
NE2D_RGB_V120F4.0_2m	Cabled module	FOV120°; F4.0	Spool
NE2D_RGB_V160F2.4_2m	Cabled module	FOV160°; F2.4	Spool



Information

As module the device is mounted on a flat ribbon cable measuring up to 2 m in length that connects to the base station. However, if the customer requirements are discussed, it may be possible to assemble a slightly longer cable (up to 3 m).



CAUTION

As module the device is mounted on a flat ribbon cable measuring up to 2 m in length that connects to the base station. However, if the customer requirements are discussed, it may be possible to assemble a slightly longer cable (up to 3 m).

3 Pin Assignment

3.1 Pin Diagram

Figure 3:
Pin Assignment SGA (top view)

	1	2
A	VDDD	SDA / DATA+
B	VSS	SCL / DATA-

Figure 4:
Pin Assignment Module Cable (camera front view)

	1	2	3	4	5	6
4-Wire Cable	VSS	SDA / DATA+	SCL / DATA-	VDDD		
6-Wire Cable	LED-	VSS	SDA / DATA+	SCL / DATA-	VDDD	LED+

Figure 5:
4-Wire Cable Pinout

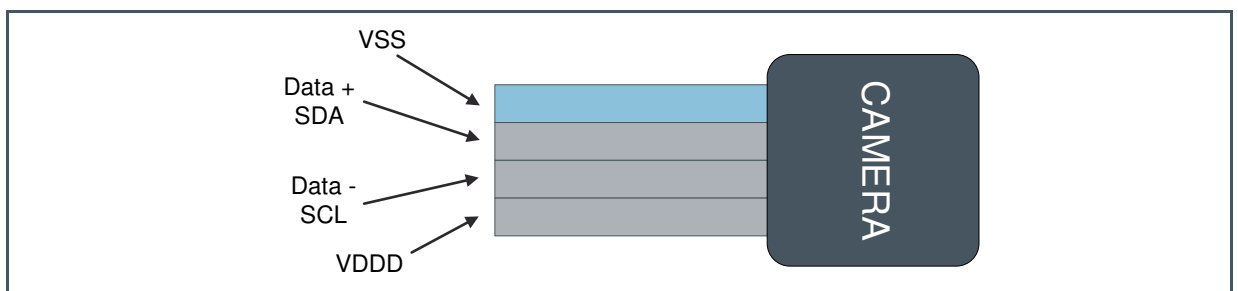
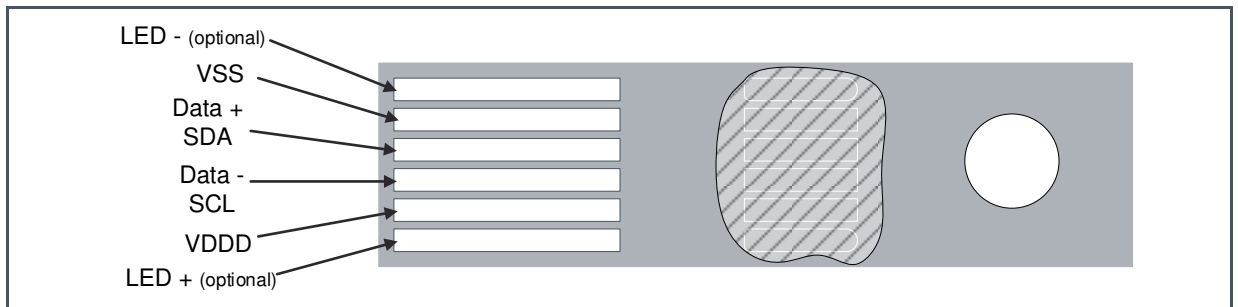


Figure 6:
6-Wire Cable FlexPCB Connector Pinout



3.2 Pin Description

Figure 7:
Pin Description of NanEye

Pin Number		Pin Name	Pin Type ⁽¹⁾	Description	
SGA	Cable 4-Wire	Cable 6-Wire			
		1	LED-	AO	LED cathode
B1	1	2	VSS	VSS	Ground supply
A2	2	3	SDA / DATA+	DIO	Serial data input, LVDS pos. output
B2	3	4	SCL / DATA-	DIO	Serial clock input, LVDS neg. output
A1	4	5	VDDD	Supply	Positive supply
		6	LED+	AI	LED anode

(1) Explanation of abbreviations:
 DIO Digital Input/Output
 AI Analog Input
 AO Analog Output

4 Absolute Maximum Ratings

Stresses beyond those listed under “Absolute Maximum Ratings” may cause permanent damage to the device. These are stress ratings only. Functional operation of the device at these or any other conditions beyond those indicated under “Operating Conditions” is not implied. Exposure to absolute maximum rating conditions for extended periods may affect device reliability.

Figure 8:
Absolute Maximum Ratings of NanEye

Symbol	Parameter	Min	Max	Unit	Comments
Electrical Parameters					
V _{VDD}	Supply Voltage to Ground	-0.5	3	V	
V _{SCL} , V _{SDA}	Input Pin Voltage to Ground	-0.5	3	V	
Electrostatic Discharge					
ESD _{HBM}	Electrostatic Discharge HBM	± 1		kV	JEDEC JESD22-A114F
Temperature Ranges					
T _A	Operating Ambient Temp	-20	60 ⁽¹⁾	°C	VRST_PIX = 0 (1.2V)
T _{100C}	Max Time Around 100°C ⁽²⁾		2	min	
T _{150C}	Max Time Around 150°C		10	sec	
T _{BODY}	Package Body Temperature		260	°C	IPC/JEDEC J-STD-020 ⁽³⁾
	Number of Reflow Cycles		1		Due to the small pad pitch, standard reflow process may need to be adjusted to achieve reliable solder result.
Storage Conditions (modules + cable)					
T _{STRG}	Storage Temp Range	-	30	°C	
RH _{NC_STRG}	Storage Humidity	-	60	%	Not applicable if products are kept sealed inside the original MBB (Moisture Barrier Bag)
	Shelf Life	-	4	year	
Storage Conditions (SGA)					
T _{STRG_SGA}	Storage Temp Range	-	40	°C	
RH _{NC_STRG_SGA}	Storage Humidity	-	90	%	According to MSL 3 storing conditions mentioned on MBB (Moisture Barrier Bag)
	Shelf Life	-	1	year	
MSL Level					
MSL _{SGA}	Moisture Sensitivity Level SGA without Lenses		3		Represents a floor life time of 168h
MSL _{M+CABLE}	Moisture Sensitivity Level Lens Module with Cable		N/A		Max floor life time including storage time max. 4 years @ max. 30 °C & 60 % rel. humidity

- (1) NanEye can withstand temperatures of 80 °C with no loss of communication. The only change on its performance it's the slight increase on the dark current/noise, which is normal for high temperatures.
- (2) UV curing process is in our conviction not causing any harm to the sensor.
- (3) The reflow peak soldering temperature (body temperature) is specified according to IPC/JEDEC J-STD-020 “Moisture/Reflow Sensitivity Classification for Nonhermetic Solid State Surface Mount Devices.” The lead finish is tin/silver (96.5% Sn, 3.5% Ag).

5 Electrical Characteristics

Figure 9:
Electrical Characteristics of NanEye

Symbol	Parameter	Conditions	Min	Typ	Max	Unit
V _{DDD}	Supply voltage		(1.6 ⁽¹⁾)1.8	2.1	2.4	V
V _{N_{RMS}V_{DDD}}	RMS noise on V _{DDD}				5	mV
V _{N_{PP}V_{DDD}}	Peak to peak noise on V _{DDD}				20	mV
P _{CLK}	Internal pixel clock (adjustable via V _{DDD})			2.8		MHz
B _{CLK}	Bit clock for serial data transmission (12x Pclk)		30	33.6	46	MHz
J _{DATA}	Jitter data clock		-20		20	% of B _{CLK}
P _{tot_1.6}	Total power consumption	V _{DDD} =1.6V ⁽¹⁾	1.5	3.1	4.7	mW
P _{tot_1.7}	Total power consumption	V _{DDD} =1.7V ⁽¹⁾	2.0	3.8	5.5	mW
P _{tot_1.8}	Total power consumption	V _{DDD} =1.8V	2.6	4.6	6.7	mW
P _{tot_2.1}	Total power consumption	V _{DDD} =2.1V	4.6	7.5	10.5	mW
P _{tot_2.4}	Total power consumption	V _{DDD} =2.4V	6.8	11.5	16.1	mW
Digital Upstream Interface						
V _{IL}	SCL,SDA low level input voltage		-0.3		0.22*V _{DDD}	V
V _{IH}	SCL,SDA high level input voltage		0.71*V _{DDD}		V _{DDD} +0.3	V
T _S	Setup time for upstream configuration relative to SCL		3			ns
T _H	Hold time for upstream configuration relative to SCL		3			ns
f _{SCL}	SCL frequency				2.5	MHz
LVDS Downstream Interface						
V _{CM}	Common mode output voltage (DATA+/-)		0.4	V _{DDD} /2	V _{DDD} -0.4	V
I _{DATA+,DATA-}	LVDS output signal current		300	500	600	μA
	Data line impedance	recommended		120		Ω
	LVDS differential peak-peak swing	120 Ω		60		mV
T _{slew, rising}	Output slew rate of rising edge			3		ns
T _{slew, falling}	Output slew rate of falling edge			3		ns

- (1) The frame rate is dependent on VDD sensor supply voltage. For as long as the frame rate is maintained >38 Fps the sensor supply can be set lower than 1.8 V down to 1.6 V minimum.

Figure 10:
Electro-Optical Characteristics of NanEye

Parameter	Value	Remark
Resolution	62 kP, 249 (H) x 250(V)	
Pixel size	3 μm x 3 μm	
Optical format	1/16"	
Pixel type	3T FSI	
Shutter type	Rolling Shutter	
Color filters	RGB (Bayer Pattern) or B&W	
Micro lenses	No	
Programmable register	Sensor parameter	Exposure time, dark level and analog gain
Programmable gain	4 steps -1.6/1/2.4/6.5dB	Analog
Exposure times	0.07 – 25 ms	Register configurable
Number of defect pixel ⁽¹⁾	<10	
Defect pixel cluster ⁽²⁾	0	
ADC	10bit	Column ADC
Frame rate	43-62 fps	Adjustable over power supply
Output interface	1x LVDS @ 38 Mbps	@50 Hz
Size	1 x 1 mm -10 μm /+30 μm	

- (1) A pixel is considered a defect pixel if in dark or at any homogeneous illumination level its value deviates more than 200 DN with the settings of INVERSE_GAIN= 2, OFFSET=3, VRST_PIXEL = 1, VREF_CDS = 2 rows in reset = 1, VDDD = 2.0 V from the median value of its 8 nearest neighbors. (In case of RGB color sensors, the nearest neighbors are considered from each color plane individually). Analysis is done at room temperature.
- (2) A defect pixel cluster is any region of 5 x 5 pixels, which contains more than 1 defect pixel.
- (3) Edge chirp of up to 100 μm from edge of chip package is allowed.
- (4) Surface scratch and dig up to 200 μm length when width above 20 μm , or of width less than 20 μm is allowed, for as long as PRNU and defect pixel specification under normal incident illumination and F# 8 is respected.

Figure 11:
Electro-Optical Parameter of NanEye⁽¹⁾⁽²⁾

Parameter	Gain=0	Gain=1	Gain=2	Gain=3	Unit
Gain Value	-1.6	1	2.4	6.5	dB
Responsivity	4.6	5.5	7.2	11.5	DN/nJ/cm ²
Full well capacity	17	15.8	13.5	6.8	ke-
QE	30	30	30	30	%
Temporal read noise in dark / dark noise	1	1.1	1.6	2.6	DN
Dynamic Range	56	58	53	49	dB
SNR max	44	41	40	38	dB
DSNU	2.8	3.5	4.7	7	DN
PRNU	5.0	4.8	5.0	5.2	%
FSD	655	890	834	808	DN

- (1) Measured on a B&W sensor at 625 nm illumination The values are all without software correction.
- (2) The settings used to get these values are those recommended by the European Machine Vision Association standard 1288 for the Machine Vision Sensors and Cameras: <http://www.emva.org/standards-technology/emva-1288/>.

Figure 12:
Lens Configuration

Parameter	F#2.7 FOV90°	F#4.0 FOV90°	F#6.0 FOV90°	F#2.8 FOV120°	F#4.0 FOV120°	F#2.4 FOV160°
F# number	2.7	4.0	6.0	2.8	4.0	2.4
FOV (diagonal in air)	90°	90°	90°	120°	120°	160° ⁽¹⁾
FOV (diagonal in water)	62°	62°	62°	86°	86°	95°
Max distortion (diagonal in air)	23%	23%	23%	50%	50%	80%
Max distortion (diagonal in water)	7.5%	7.5%	7.5%	16%	16%	20%
EFL (mm)	0.66	0.66	0.66	0.5	0.5	0.45
Aperture (μm)	220	176	120	176	120	180
MTF @ ½ Nyquist @ center (simulated)	69%	73%	65%	66%	73%	57%
MTF @ ½ Nyquist @ 50% diagonal filed Tangential (simulated)	47%	51%	51%	53%	58%	47%
Best focus (mm)	13	10	10	8	8	10
Depth of focus	5 - 40	3.5 - 50	3 - 50	4 - 40	3 - 50	4 - 50
Module Size (mm)	1x1x1.69	1x1x1.72	1x1x1.74	1x1x1.48	1x1x1.43	1x1x1.40

- (1) Full effective FOV cannot be guaranteed due to lens shading effects in the corners.

6 Typical Operating Characteristics

Figure 13:
B&W Spectral Response

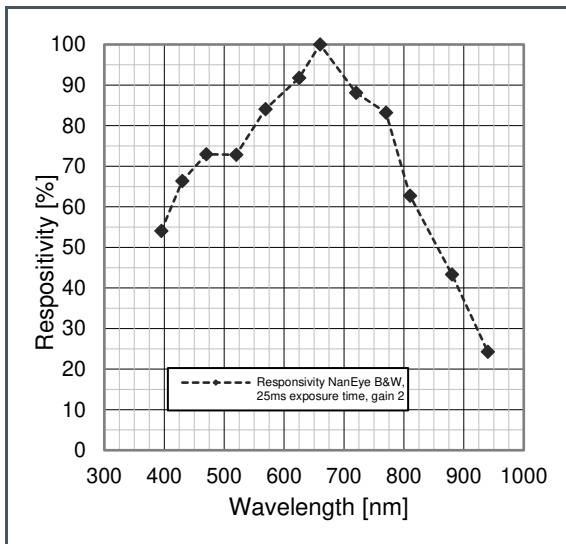


Figure 14:
RGB Spectral Response

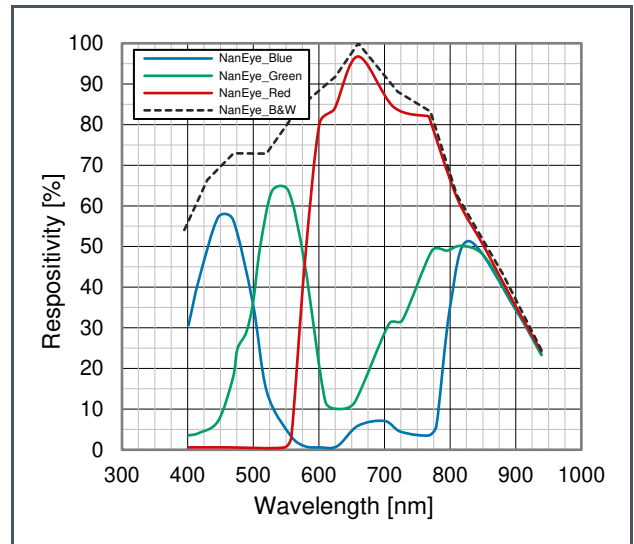


Figure 15:
Frame Rate vs Voltage⁽¹⁾⁽²⁾

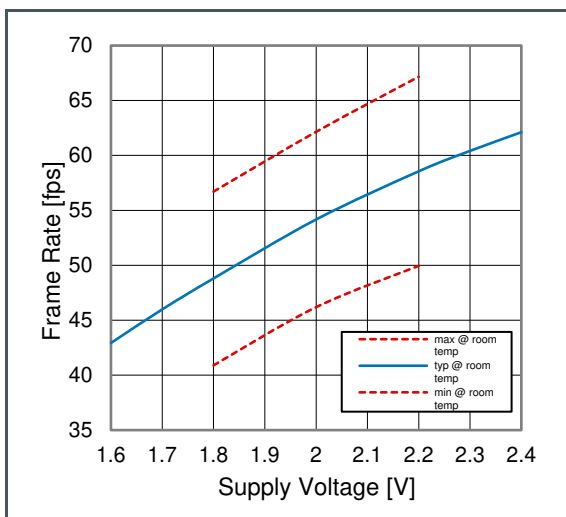
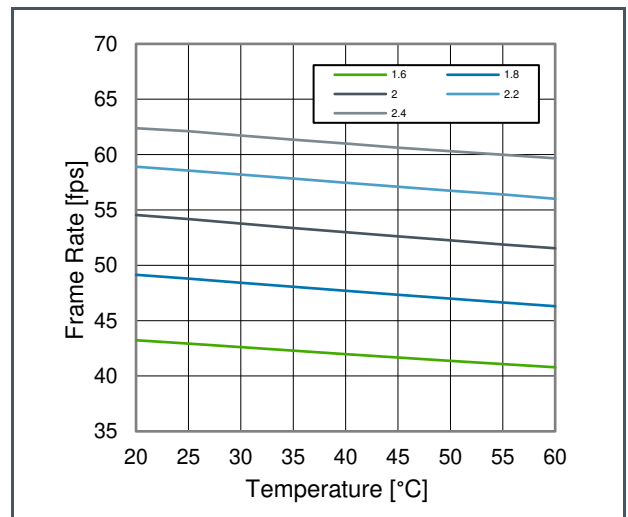
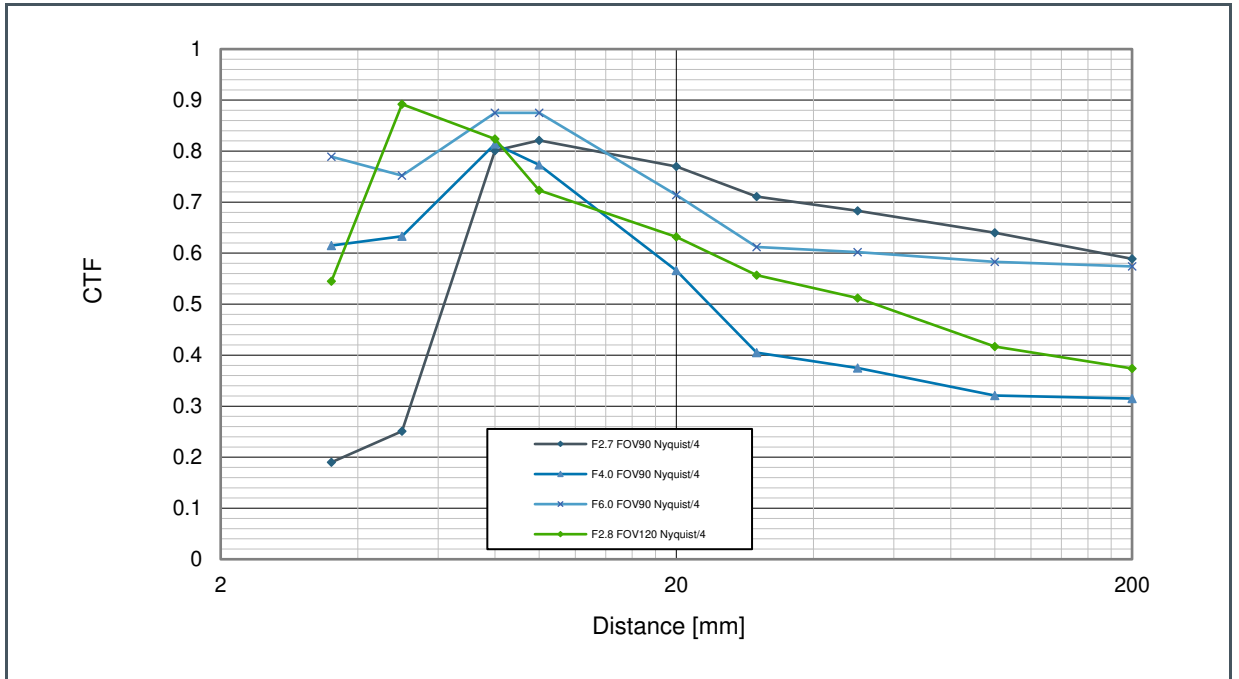


Figure 16:
Frame Rate vs Temperature⁽²⁾



- (1) Min/max values based on current available test results are for SGA parts without cable, limits may be adjusted when additional test data are available.
- (2) The frame rate is dependent on VDD sensor supply voltage. For as long as the frame rate is maintained >38 Fps the sensor supply can be set lower than 1.8 V down to 1.6 V minimum.

Figure 17:
NanEye CTF Measurements



7 Functional Description

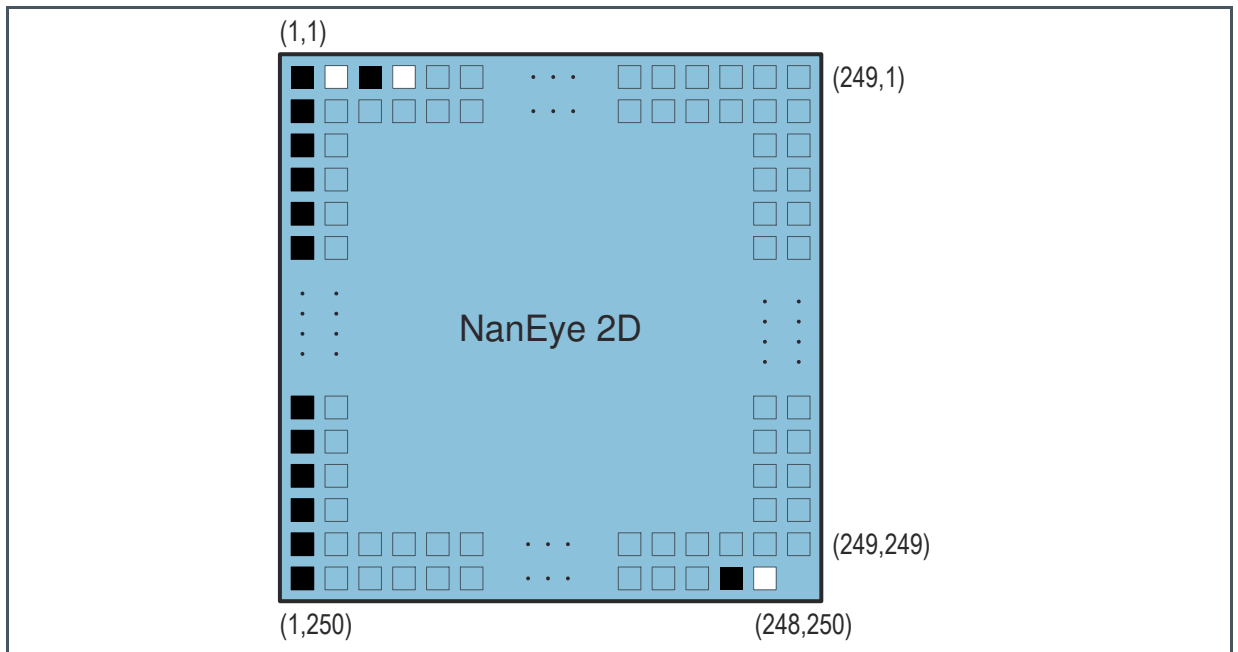
7.1 Sensor Architecture

Figure 2 shows the image sensor architecture. The internal state machine generates the necessary signals for image acquisition. The image is stored in the pixels (rolling shutter) and is read out sequentially, row-by-row. On the pixel output, an analog gain is possible. The pixel values then passes to a column ADC cell, in which ADC conversion is performed. The digital signals are then read out over a LVDS channel.

7.1.1 Pixel Array

The pixel array consists of 249 x 250 square rolling shutter pixels with a pitch of 3 μm (3 μm x 3 μm). This results in an optical area of 747 μm x 750 μm (1.06 mm diameter).

Figure 18:
Pixel Array



The pixels are designed to achieve maximum sensitivity with low noise.

There are two electrical black pixels and two electrically saturated pixels on the upper left corner and one black pixel and one white pixel on the lower right corner, which may be used to check consistency of received data.

7.1.2 Analog Front End

The analog front end consists of 2 major parts, a column amplifier block and a column ADC block.

The column amplifier prepares the pixel signal for the column ADC. The column ADC converts the analog pixel value to a 10-bit value and can apply a gain. All gain and offset settings can be programmed using the I²C interface.

7.1.3 LVDS Block

The LVDS block converts the digital data coming from the column ADC into standard serial LVDS data running at around 30 Mbps. During transfer of the image data, the pixel values are transmitted in bit serial manner with 12 bits and embedded clock (start bit (1-bit) + data (10 bits) + stop bit (1-bit)). The sensor has one LVDS output pair.

7.1.4 State Machine

The state machine will generate all required control signals to operate the sensor. The clock is derived from an on-chip master clock generator running at about 2.5 MHz. This sequencer can be programmed through the I²C interface. A detailed description of the registers and sensor programming can be found in section 7.5 and 8 of this document.

7.1.5 Single Ended Serial Interface

The single ended serial interface is used to load the register with data. It is multiplexed with the LVDS interface, data can be send in the frame windows of the receiving image information. The data in these register is used by the state machine and ADC block while driving and reading out the image sensor. Features like exposure time, gain and offset can be programmed using this interface. Section 7.5 and 8 contain more details on register programming.

7.1.6 Optics

The optional optics available for the sensor is a high performance miniature lens module. It will be directly mounted on the image sensor and has its best focus position defined by design, so no mechanical set of focus is needed. The material is based on B33 (Borofloat glass). The design is made in such way that the surface towards the object is flat, so the lens performance is not influenced by the medium between the object and lens. Only the opening angle of the lens is reduced when the system operates in water.

7.2 Driving the NanEye

The NanEye image sensor is a CMOS based system on chip, which means that no external component close to the sensor is needed to run the sensor, not even an external capacitor.

7.2.1 Supply Voltage

The sensor operates from a single supply voltage VDDD. All blocks are supplied by this voltage. In addition, a VDDPIX (reset voltage for the pixels) is generated internally.

For reference, schematic and external components please refer to section 9 Application Information.

7.2.2 Start-Up Sequence

The chip is fully self-timed. After power on, the sensor performs an internal power on reset, and then starts autonomous operation and transmission of image data in rolling shutter mode, using maximum exposure time.

7.2.3 Reset Sequence

No special reset sequence needed.

7.2.4 Frame Rate

If required, the sensor data rate can be modulated slightly by adjusting the sensor supply voltage (see Figure 15 and Figure 16). If multiple sensors are to be synchronized, this is possible by dynamically adjust the supply voltage to control the frame rate.

7.3 Matrix Readout

After power on the sensor starts to loop autonomously the sequence as detailed below:

Figure 19:
Sequence of Operation Graph

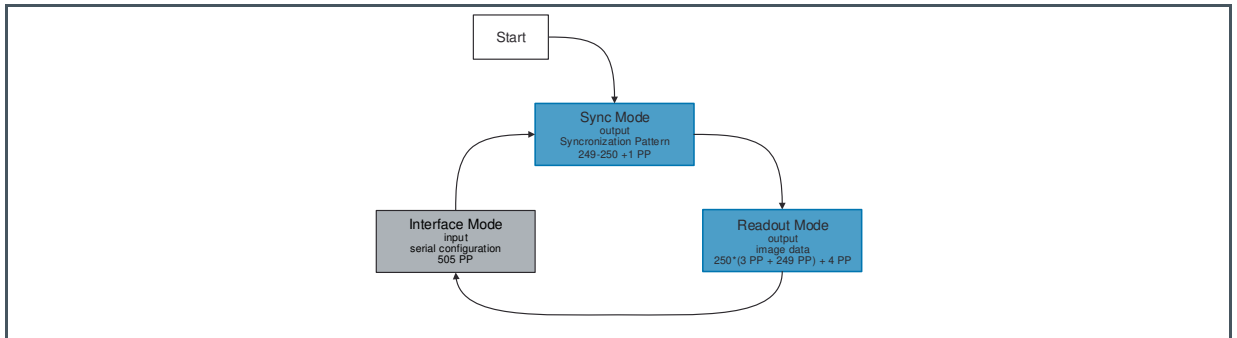


Figure 20:
Sequence of Operation

Phase #	Status	Start Bit	Data XOR	Interface Status	Duration	Function
1.1	Transmission of continuous 0	0	Yes	LVDS out	3 PP ⁽¹⁾	Row 1 Readout
1.2	Transmission of 249 pixel values (first pixel is black)	1	Yes	LVDS out	249 PP	
2.1	Transmission of continuous 0	0	Yes	LVDS out	3 PP	Row 2 Readout
2.2	Transmission of 249 pixel values (first pixel is black)	1	Yes	LVDS out	249 PP	
Readout of All 250 Rows, Repeat x.1 and x.2 Consecutively						
250.1	Transmission of continuous 0	0	Yes	LVDS out	3 PP	Row 250 Readout
250.2	Transmission of 248 pixel values (first pixel is black)	1	Yes	LVDS out	248 PP	
251	Transmission of continuous 0	0	No	LVDS out	4 PP	Indication for end of frame
252	Time for Serial configuration ⁽²⁾	--	--	Serial configuration input	505 PP	Register configuration
253	Transmission of synchronization pattern before start of frame, continuous 0	0	Yes	LVDS out	249 - 250 PP	Resynchronization with sensor data & pixel clock
253a	At the end of the synchronization pattern, a random bit sequence (can be all 0) is transmitted while switching to the first start of line identification.	X	Yes	Change to readout state	1 PP	Change of state; do filter this word and ignore it.
Restart at 1.1						

(1) PP = Pixel Period

- (2) It is recommended to drive the data bus during the entire upstream communication phase, even if no register data is sent to the sensor. This is to avoid pick up of EMI on the non-driven lines floating during the communication.



CAUTION

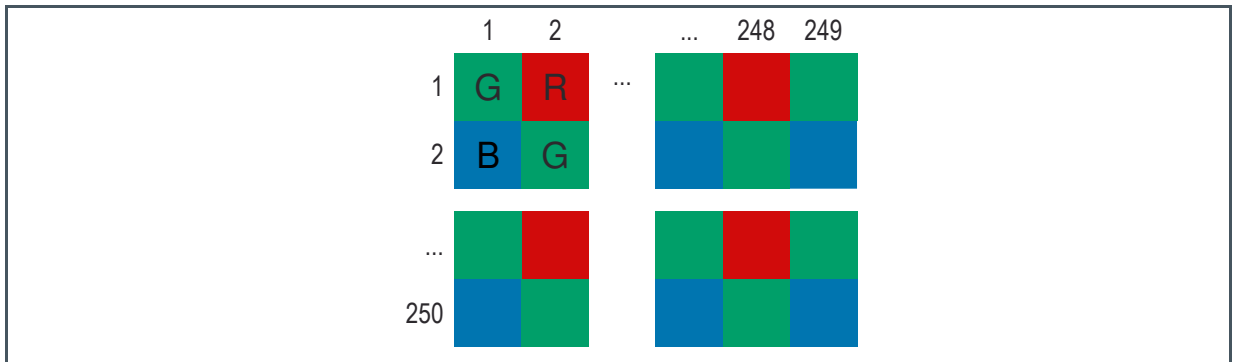
The sensor is fully self-timed and cycles between the downstream and the upstream mode. Therefore, it is the user's responsibility to tristate the upstream drivers of the serial configuration link prior to the start of data transmission from the sensor. If the bus is still driven by the upstream configuration buffers when the sensors starts downstream of the first pixels information, these may not be captured correctly.

Due to the limited current output from the sensor it is not expected that conflicting drive of the data lines will permanently destroy the sensor, however this condition would seriously degrade the data integrity and is not qualified in terms of device reliability and life time.

7.3.1 Color Filters

When a color version of the NanEye is used, the color filters are applied in a Bayer pattern. The first pixel read-out, pixel (1,1), is the top left ion and has a green filter.

Figure 21:
Colored Version Bayer Pattern Matrix

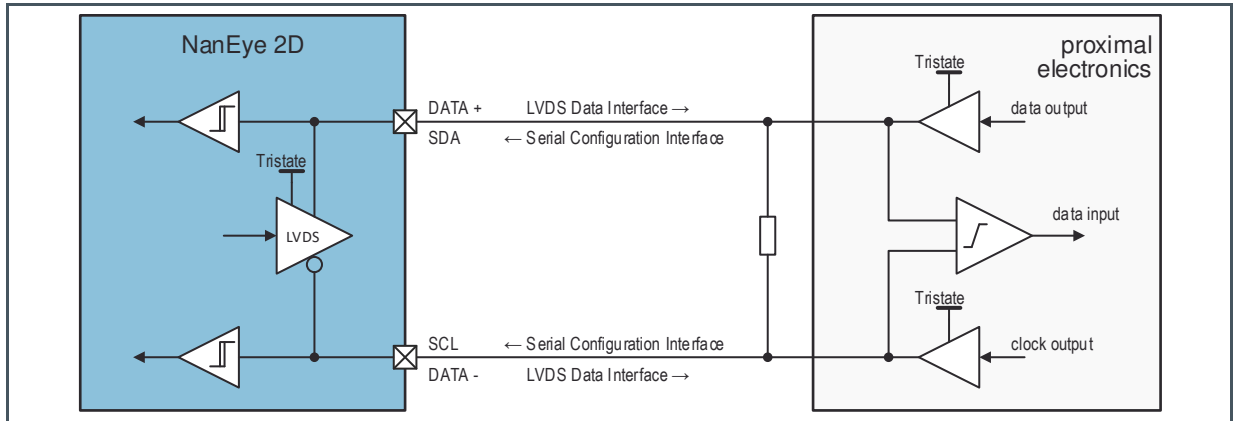


7.4 Serial Interface

The chip features a bi-directional data interface. During transfer of the image data, the pixel values are transmitted in bit serial manner over an LVDS channel with an embedded clock. After each frame, the data interface is switched for a defined time to an upstream configuration interface. This needs a synchronization every time it passes from the upstream to a new downstream mode at the image

receiver side. The positive LVDS channel holds the serial configuration data and the negative channel holds the serial interface clock.

Figure 22:
Data Interface Between Sensor and Proximal Electronics



7.4.1 LVDS Data Interface (Downstream)

The NanEye_2D chip works with an on chip clock of ~2.5 MHz. The image data on chip is generated as a 10-bit representation. A start and a stop bit is then added to the data. The bit serial data interface then transmits the data at 12 x 2.5 MHz bit rate ($\pm 20\%$), ~ 30 MHz.

Data Word

The data word is EXOR gated with the serial clock before sent bit serial according to the following scheme:

Figure 23:
Data Word Encoding

Bit #	0	1	2	3	4	5	6	7	8	9	10	11
Function	Start		Pixel Data (10 bits)								Stop	
Content	1	MSB									LSB	0

An example of this is:

- 10 bits data word: 0110001101
- Including start and stop bits: **101100011010**
- 12 bits word EXOR with the data clock:
 - 10 10 10 10 10 10 10 10 10 10 10 10 - data clock (main clock)
 - 11 00 11 11 00 00 00 11 11 00 11 00 – 12-bit data @ data clock frequency

- 01 10 01 01 10 10 10 01 01 10 01 10 - data word result
- Start of Row

The start of a line identification consists in 3x sending the word 00 with start and stop bits also at 0.

Figure 24:
Start of Line Word Encoding

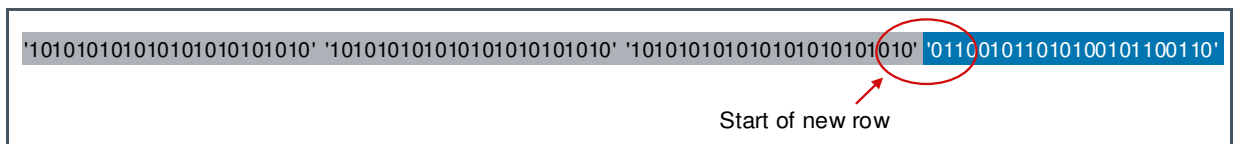
Bit #	0	1	2	3	4	5	6	7	8	9	10	11
Function	Start					Start Row					Stop	
Content	0	0	0	0	0	0	0	0	0	0	0	0

An example of this is:

- 10 bits data word: 0000000000
- Including start and stop bits: 000000000000
- 12 bits word EXOR with the data clock:
 - 10 10 10 10 10 10 10 10 10 10 10 10 - data clock (main clock)
 - 00 00 00 00 00 00 00 00 00 00 00 00 – 12-bit at 0's @ data clock frequency
 - 10 10 10 10 10 10 10 10 10 10 10 10 - start of line word result

The resulting start word is sent 3x at the start of a new row. The beginning of a new row can be easily identified by the detection of the first start bit:

Figure 25:
Start of Row Identification



7.4.2 Serial Configuration Interface (Upstream)

The upstream data interface consists of a single 16-bit write only register. The register is written by sending a 4-bit update code, followed by a 3-bit register address (only register 00 is implemented) and 16-bit register data.

Maximum frequency of SCL can be 2.5 MHz.

All data is written MSB to LSB. Data is captured on the rising edge of SCL. It is recommended to change SDA on the falling edge of SCL to grant maximum setup and hold times.

The below table indicates the sequence of writing update code, register address and register data.

Figure 26:
Register Update Sequence

#Rising Edge of SCL After Reset	1	2	3	4	5	6	7	8	9	...	22	23	24
Function	update code			register address			register content (16-bit)			reset			
Content	1	0	0	1	0	0	0	MSB				LSB	

The content of the input shift register is updated to the effective register, once a correct update code (1001) has been received and shifted by 24 clocks. The input shift register is reset to all 0's 24 clocks after the first high value as the SDA input is received, regardless of whether a correct update code is detected or not.

7.5 Sensor Programming

This section explains how the NanEye can be programmed using the on-board registers.

7.5.1 Exposure Time Control

Exposure time is defined based on the amount of rows in reset, set by user. The NanEye sensor feature a rolling shutter, which means one row is selected for readout while a defined number of previous rows are in reset, and all the others rows are in integration. The range goes from [0 - 248] lines. The default value is 1 "Nrows_in_Reset = 00000001".

The effective exposure time thus is given by the formula:

Equation 1:

$$T_{exp} = \frac{\max[N_{rows} - N_{RowsInReset}; 2]}{N_{rows}} \times F_{time}$$

Where:

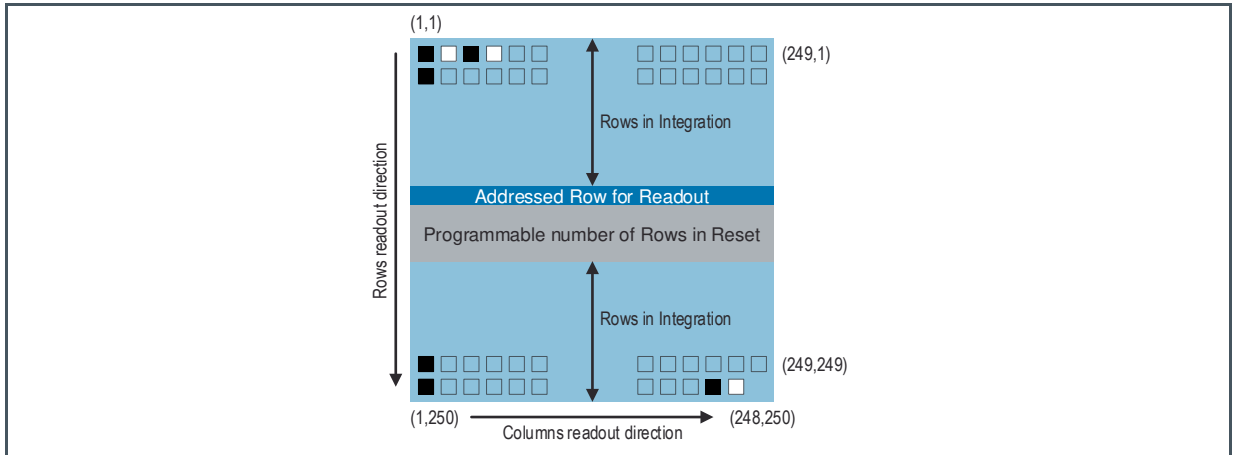
T_{exp} = The effective exposure time

N_{rows} = 250

$N_{RowsInReset}$ = Register setting *rows_in_reset* [0 ...248]

F_{time} = The time for a frame readout (22.7 ms for NanEye 2D @ VDD = 2.1 V)

Figure 27:
Row Readout Operation



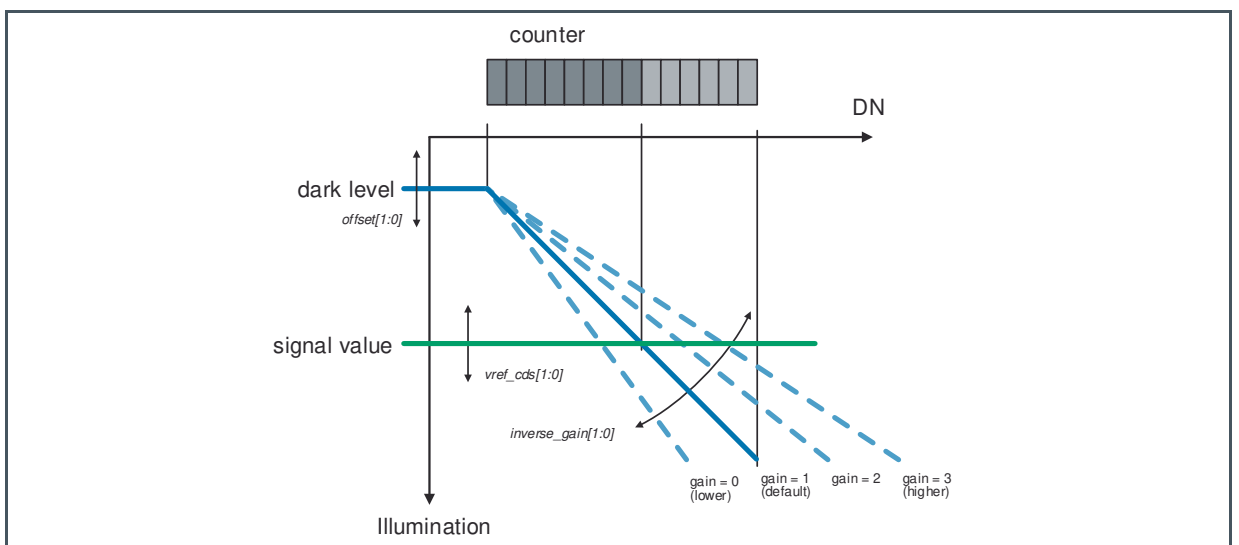
7.5.2 Offset and Analog Gain

It is a 10-bit full linear ADC. The architecture of the ADC allows to program several parameter:

- Voltage Reference for signal (*vref_cds[1:0]*)
- Ramp Gain (*inverse_gain[1:0]*)
- Ramp Offset Voltage (*offset[1:0]*)

See the configurable values in section 8 Register Description.

Figure 28:
ADC Settings



8 Register Description

8.1 Detailed Register Description

Figure 29:
CONFIGURATION Register

Addr: 00h		CONFIGURATION		
15:14	VREF_CDS[1:0]	10b	WO	Sets CDS reference voltage: 0: 1.3 V 1: 1.4 V 2: 1.5 V (recommended) 3: 1.6 V
13:12	VRST_PIXEL[1:0]	10b	WO	Sets pixel reset voltage: 0: 1.2 V 1: 1.3 V (recommended) 2: 1.4 V (do not use)⁽¹⁾ 3: 1.5 V (do not use)
11:10	OFFSET[1:0]	01b	WO	Sets ADC ramp offset (dark level): 0: Low 1: Default 2: Mid 3: High
9:8	INVERSE_GAIN[1:0]	10b	WO	Sets inverse ADC ramp gain: 0: Gain = 3 1: Gain = 2 2: Gain = 1 3: Gain = 0
7:0	ROWS_IN_RESET[7:0]	01h	WO	Sets number of rows in reset (exposure time): 0: 0 rows (not recommended) ⁽²⁾ 1: 1 row 2: 2 rows ... 248: 248 rows 249: do not use ... 255: do not use

(1) It is recommended to set VRST_PIXEL[1:0] to 01b (1.3 V) direct after startup of the sensor.

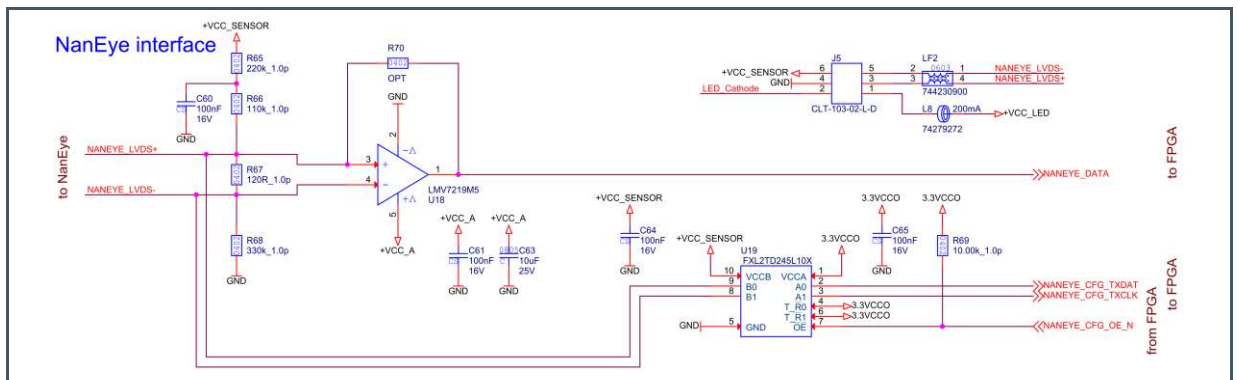
(2) "Soft Rest Mode" will increase brightness but also FPN.

9 Application Information

9.1 Recommended LVDS Receiver Electronics

The direct interface of the LVDS data to an FPGA or DSP differential input is not guaranteed. It is recommended to use a LVDS detections circuit based on a fast comparator, which fixes the LVDS signals common mode.

Figure 30:
NanEye Interface Schematic (for information only)



In order to increase the robustness of the de serialization under the presence of significant jitter which should be expected from the on chip oscillator, the data is EXOR combined with the data clock.

To reliably de serialize the incoming data, the receiver side should sample the data at least with 300 MHz to properly detect the phase of the transitions.

When defining the drive strength of the upstream drivers in the proximal circuitry it has to be considered that the serial clock and the serial data will couple to each other over the bit lines termination resistor.

Driving the serial configuration data should be carefully designed along with the cables inductance to avoid signal over shoot at the chip side. It is recommended to use slew rate controlled drivers with a low slew rate. No distal termination of the data lines is implemented on chip.



CAUTION

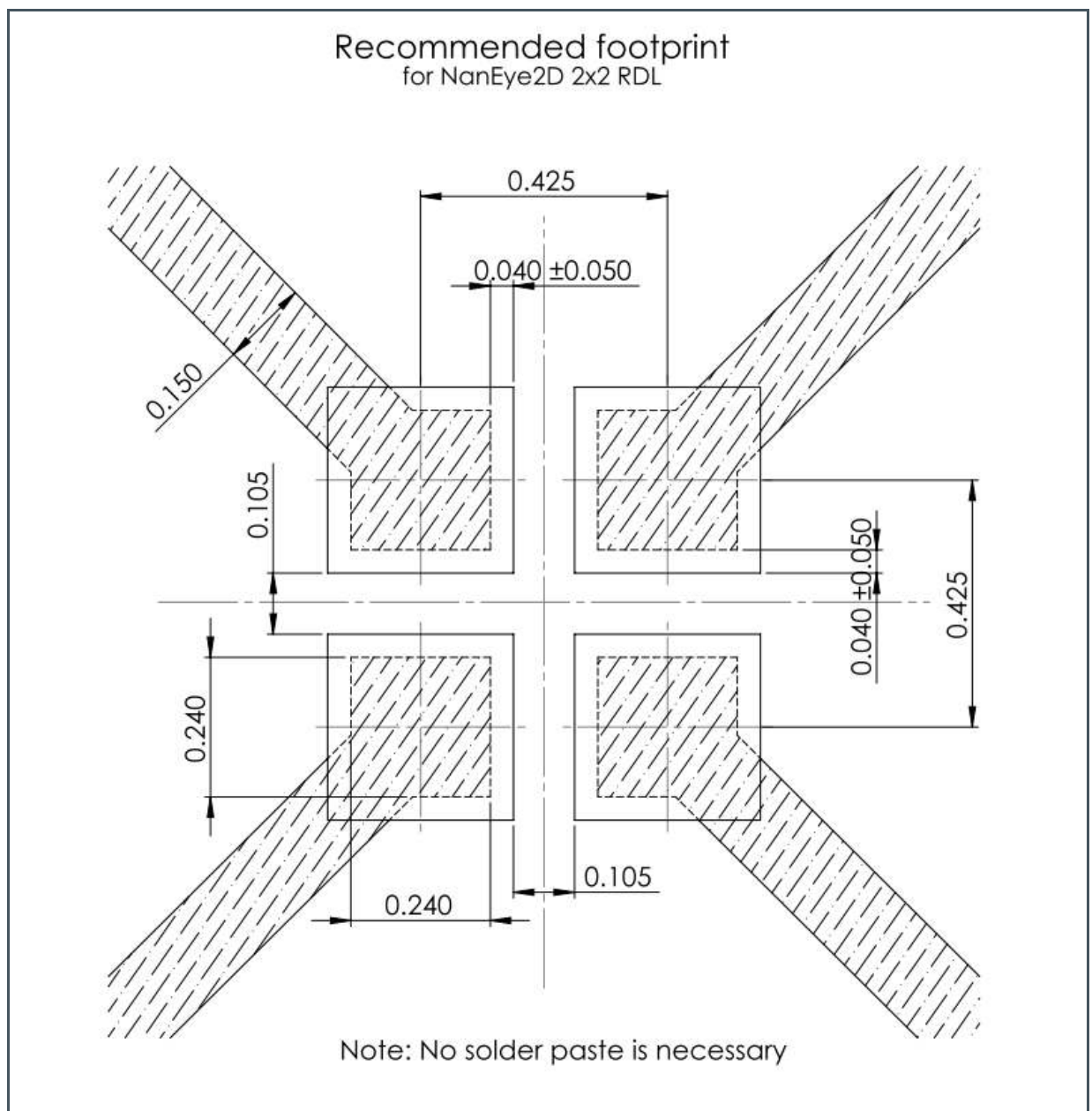
The PCB connector may short VDDD and LED+ inside the socket during insertion or removal. Switch off the LED supply before plugging in/out the PCB connector or use appropriate protection

9.2 Application Notes

It is possible to correct the “reset line” artefact. Please refer to the application note “NanEye_NanEyeStereo_AN000447”.

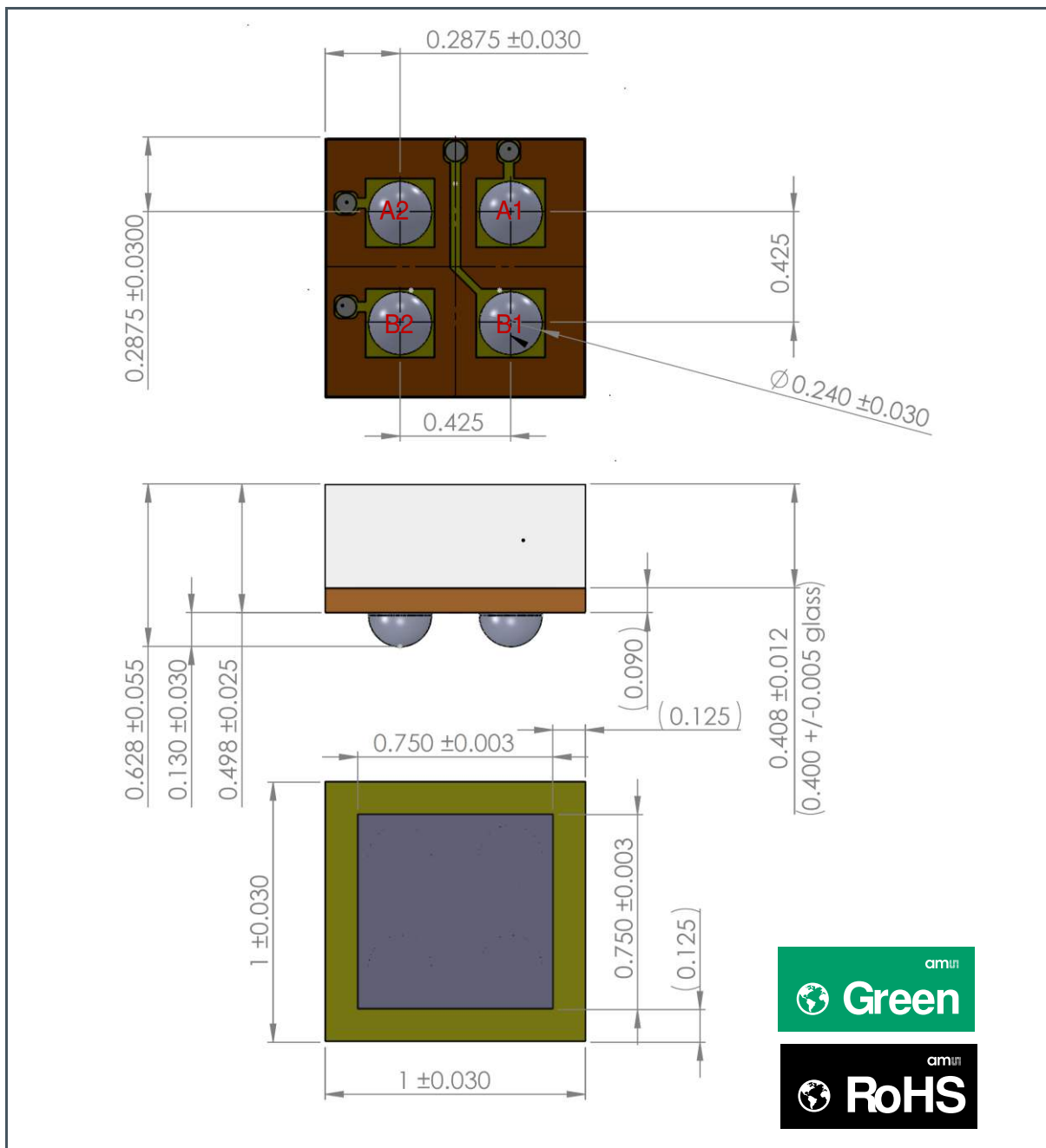
9.3 PCB Layout

Figure 31:
 SGA 2x2 Footprint and Layout



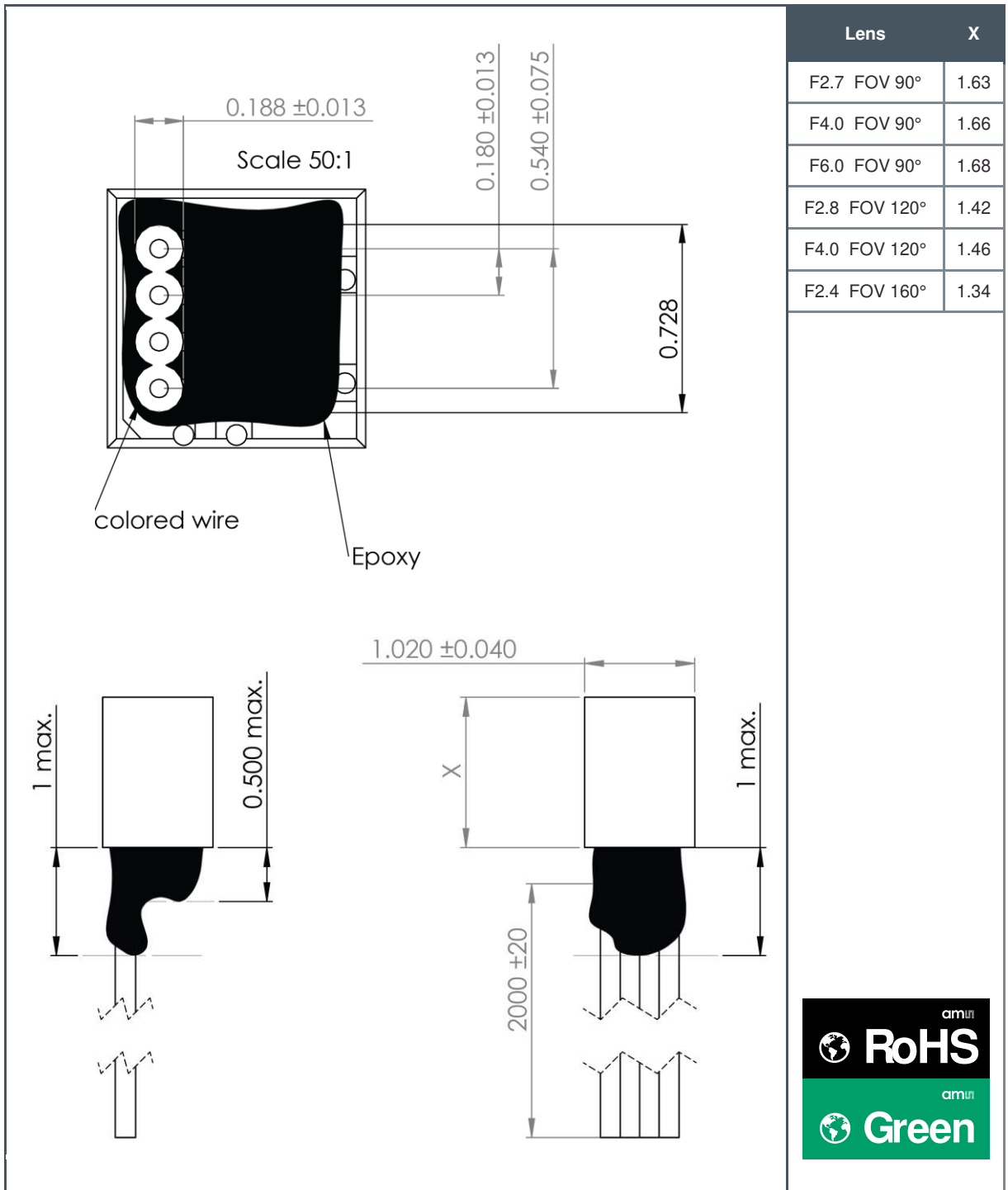
10 Package Drawings & Markings

Figure 32:
SGA 2x2 Package Outline Drawing Round Contacts (bottom view)



- (1) All dimensions are in millimeters. Angles in degrees.
- (2) If not otherwise noted all tolerances are ± 0.04 mm.
- (3) This package contains no lead (Pb).
- (4) This drawing is subject to change without notice.

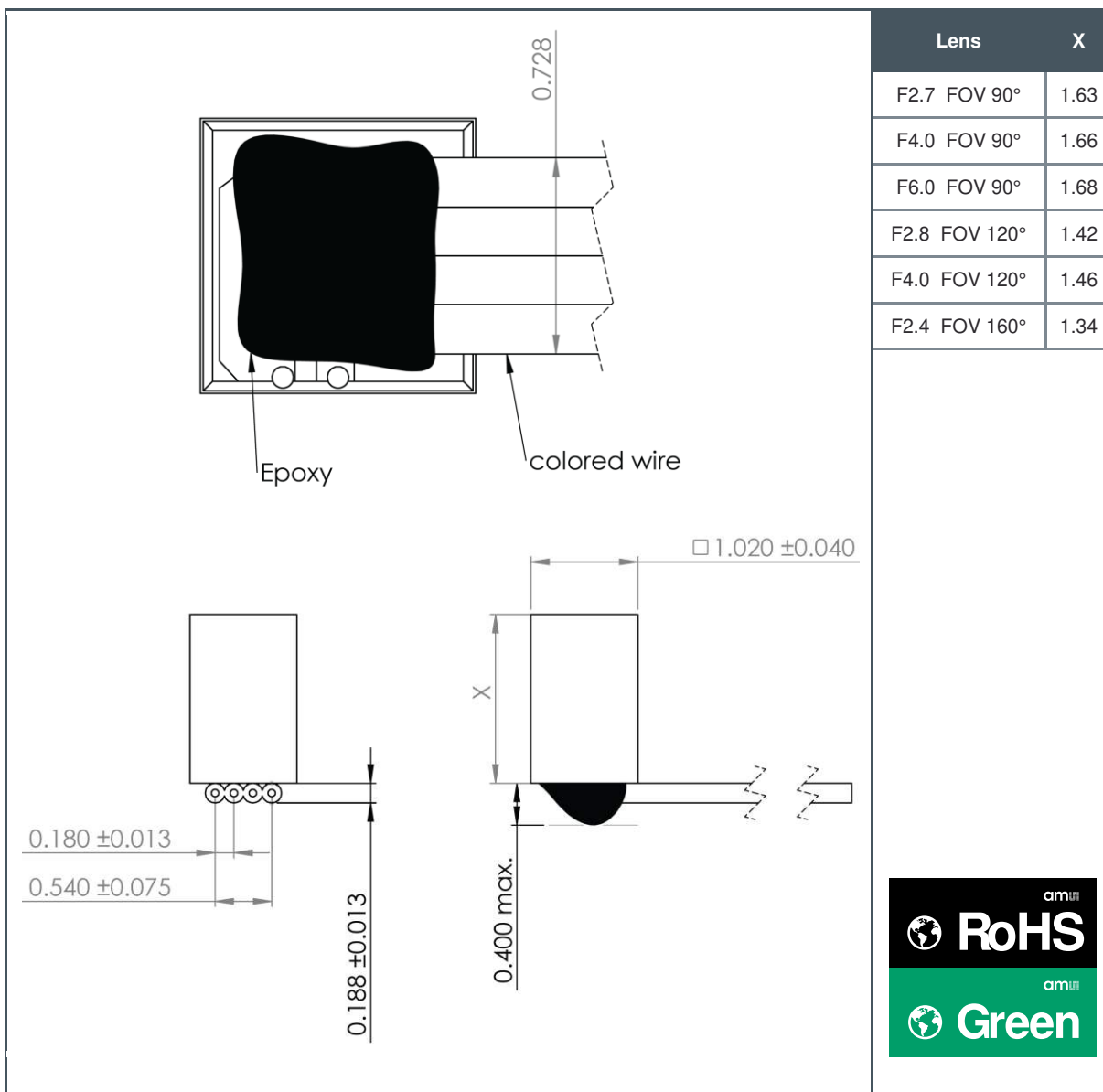
Figure 33:
NanEye with Lens and Cable Soldered Dipped (Bended) Package Outline Drawing



- (1) All dimensions are in millimeters. Angles in degrees.
- (2) If not otherwise noted all tolerances are ± 0.1 mm.
- (3) This package contains no lead (Pb).
- (4) This drawing is subject to change without notice.

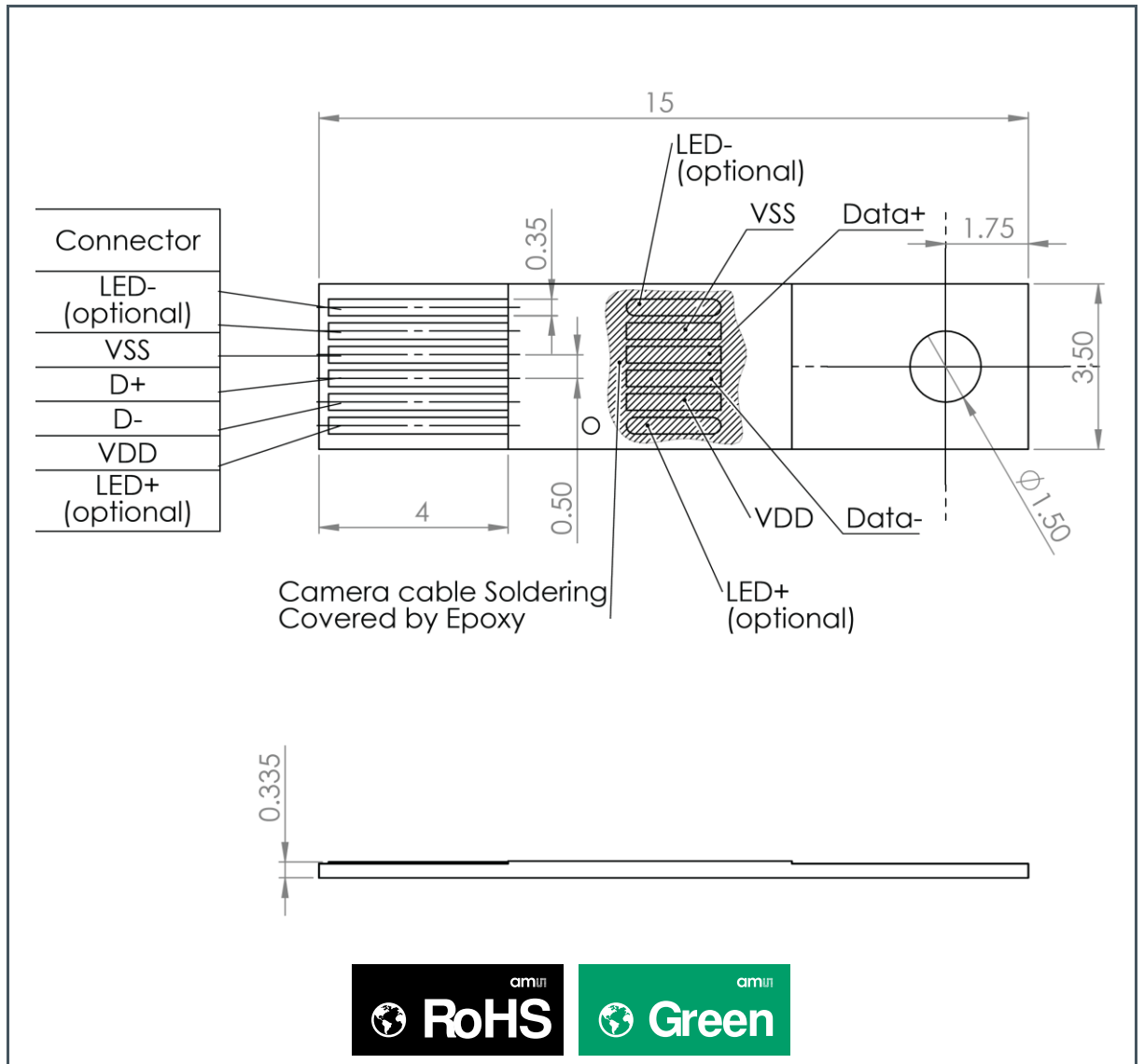


Figure 34:
NanEye with Lens and Cable Soldered Dipped (90°) Package Outline Drawing



- (1) All dimensions are in millimeters. Angles in degrees.
- (2) If not otherwise noted all tolerances are ± 0.1 mm.
- (3) This package contains no lead (Pb).
- (4) This drawing is subject to change without notice.

Figure 35:
FlexPCB Connector Outline Drawing

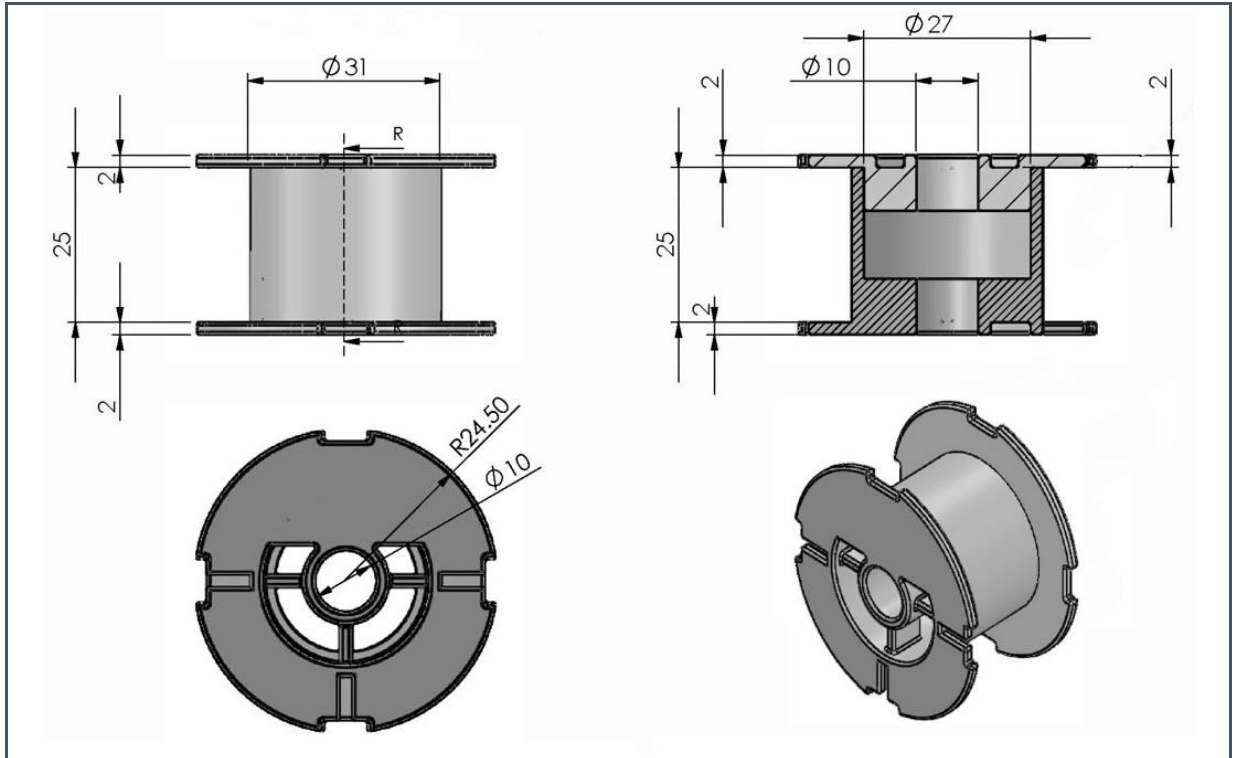


- (1) All dimensions are in millimeters. Angles in degrees.
- (2) If not otherwise noted all tolerances are ± 0.1 mm.
- (3) This package contains no lead (Pb).
- (4) This drawing is subject to change without notice.



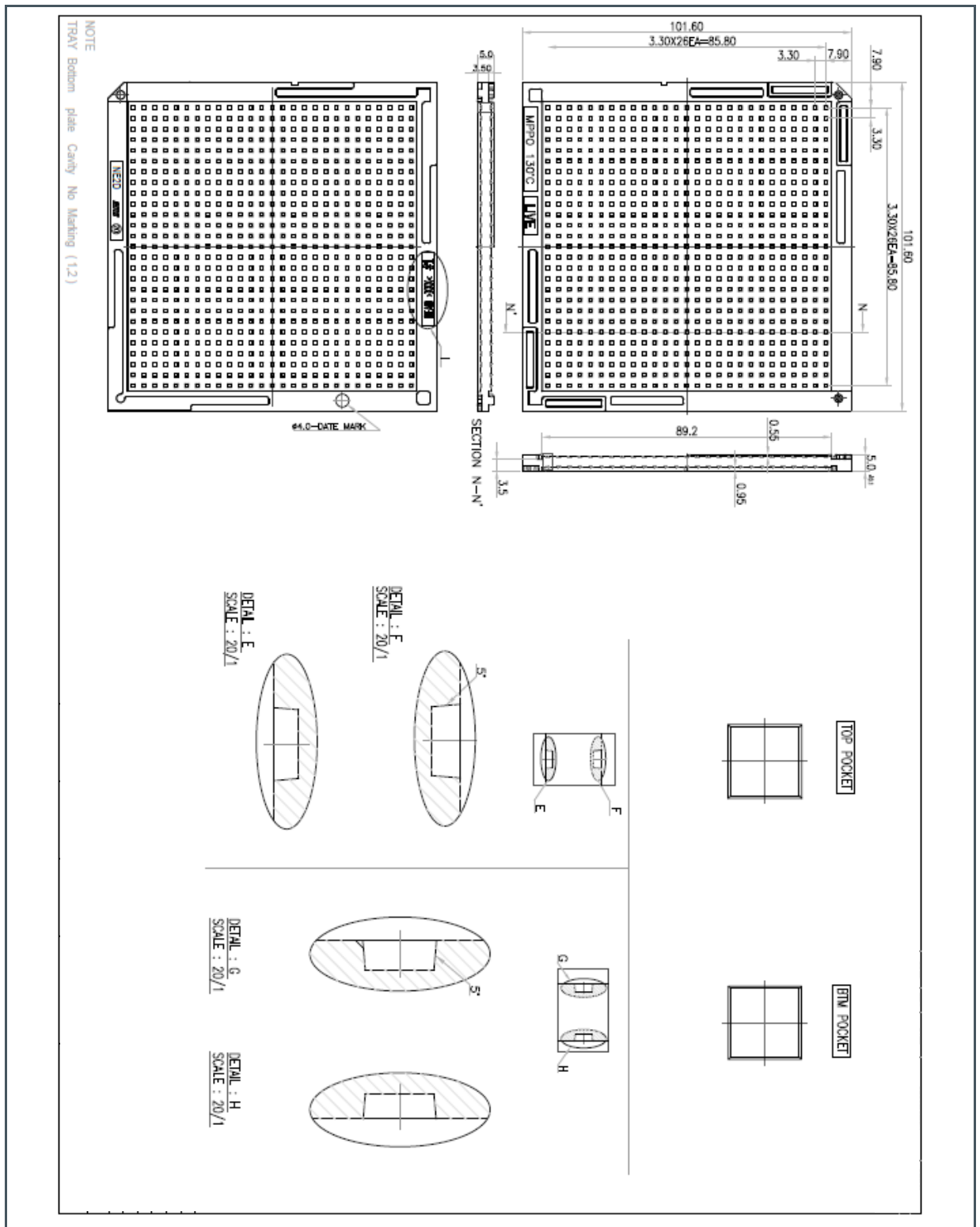
11 Tape & Reel Information

Figure 36:
Spool Dimensions for Module plus Cable Shipments



- (1) All dimensions are in millimeters. Angles in degrees.
- (2) If not otherwise noted all tolerances are ± 0.1 mm.
- (3) This drawing is subject to change without notice.

Figure 37:
Tray Dimensions for SGA Module Shipments⁽¹⁾



- (1) SGA modules are placed "face-up" in the trays. Pin orientation is not controlled.
- (2) All dimensions are in mm.

12 Appendix

12.1 Evaluation System

Optionally with the NanEye Module, **ams** provides a base station and software to run the device on a PC in real-time with all necessary image corrections. The complete system consists of the module, the USB base station and the PC software.

13 Revision Information

Document Status	Product Status	Definition
Product Preview	Pre-Development	Information in this datasheet is based on product ideas in the planning phase of development. All specifications are design goals without any warranty and are subject to change without notice
Preliminary Datasheet	Pre-Production	Information in this datasheet is based on products in the design, validation or qualification phase of development. The performance and parameters shown in this document are preliminary without any warranty and are subject to change without notice
Datasheet	Production	Information in this datasheet is based on products in ramp-up to full production or full production which conform to specifications in accordance with the terms of ams AG standard warranty as given in the General Terms of Trade
Datasheet (discontinued)	Discontinued	Information in this datasheet is based on products which conform to specifications in accordance with the terms of ams AG standard warranty as given in the General Terms of Trade, but these products have been superseded and should not be used for new designs

Changes from previous version to current revision v8-00	Page
Clarified storage conditions	8

- Page and figure numbers for the previous version may differ from page and figure numbers in the current revision.
- Correction of typographical errors is not explicitly mentioned.

14 Legal Information

Copyrights & Disclaimer

Copyright ams AG, Tobelbader Strasse 30, 8141 Premstaetten, Austria-Europe. Trademarks Registered. All rights reserved. The material herein may not be reproduced, adapted, merged, translated, stored, or used without the prior written consent of the copyright owner.

Devices sold by ams AG are covered by the warranty and patent indemnification provisions appearing in its General Terms of Trade. ams AG makes no warranty, express, statutory, implied, or by description regarding the information set forth herein. ams AG reserves the right to change specifications and prices at any time and without notice. Therefore, prior to designing this product into a system, it is necessary to check with ams AG for current information. This product is intended for use in commercial applications. Applications requiring extended temperature range, unusual environmental requirements, or high reliability applications, such as military, medical life-support or life-sustaining equipment are specifically not recommended without additional processing by ams AG for each application. This product is provided by ams AG "AS IS" and any express or implied warranties, including, but not limited to the implied warranties of merchantability and fitness for a particular purpose are disclaimed.

ams AG shall not be liable to recipient or any third party for any damages, including but not limited to personal injury, property damage, loss of profits, loss of use, interruption of business or indirect, special, incidental or consequential damages, of any kind, in connection with or arising out of the furnishing, performance or use of the technical data herein. No obligation or liability to recipient or any third party shall arise or flow out of ams AG rendering of technical or other services.

RoHS Compliant & ams Green Statement

RoHS Compliant: The term RoHS compliant means that ams AG products fully comply with current RoHS directives. Our semiconductor products do not contain any chemicals for all 6 substance categories plus additional 4 substance categories (per amendment EU 2015/863), including the requirement that lead not exceed 0.1% by weight in homogeneous materials. Where designed to be soldered at high temperatures, RoHS compliant products are suitable for use in specified lead-free processes.

ams Green (RoHS compliant and no Sb/Br/Cl): ams Green defines that in addition to RoHS compliance, our products are free of Bromine (Br) and Antimony (Sb) based flame retardants (Br or Sb do not exceed 0.1% by weight in homogeneous material) and do not contain Chlorine (Cl not exceed 0.1% by weight in homogeneous material).

Important Information: The information provided in this statement represents ams AG knowledge and belief as of the date that it is provided. ams AG bases its knowledge and belief on information provided by third parties, and makes no representation or warranty as to the accuracy of such information. Efforts are underway to better integrate information from third parties. ams AG has taken and continues to take reasonable steps to provide representative and accurate information but may not have conducted destructive testing or chemical analysis on incoming materials and chemicals. ams AG and ams AG suppliers consider certain information to be proprietary, and thus CAS numbers and other limited information may not be available for release.

Headquarters

ams AG
Tobelbader Strasse 30
8141 Premstaetten
Austria, Europe
Tel: +43 (0) 3136 500 0

Please visit our website at www.ams.com

Buy our products or get free samples online at www.ams.com/Products

Technical Support is available at www.ams.com/Technical-Support

Provide feedback about this document at www.ams.com/Document-Feedback

For sales offices, distributors and representatives go to www.ams.com/Contact

For further information and requests, e-mail us at ams_sales@ams.com