

EVALUATION KIT
AVAILABLE

28V Linear Li+ Battery Charger with Smart Autoboot Assistant

MAX8814

General Description

The MAX8814 intelligent, stand-alone constant-current, constant-voltage (CCCV), thermally regulated linear charger is designed for charging a single-cell lithium-ion (Li+) battery. The MAX8814 integrates the current-sense circuit, MOSFET pass element, thermal-regulation circuitry, and eliminates the reverse-blocking Schottky diode to create the simplest and smallest charging solution for handheld equipment.

The IC controls the charging sequence from the pre-qualification state through constant-current fast-charge and the final constant voltage charge. Proprietary thermal-regulation circuitry limits the die temperature during fast-charging or when the IC is exposed to high ambient temperatures, allowing maximum charging current without damaging the IC.

The MAX8814 achieves high flexibility by providing an adjustable fast-charge current through an external resistor. Other features include an active-low control input ($\overline{\text{EN}}$) and an active-low input power-source detection output (POK). The IC also features a booting assistant circuit that distinguishes input sources and battery connection and provides an output signal (ABO) for system booting.

The MAX8814 accepts an input supply range from 4.25V to 28V, but disables charging if the input voltage exceeds +7V to protect against unqualified or faulty AC adapters. The IC operates over the extended temperature range (-40°C to +85°C) and is available in a compact 8-pin thermally enhanced TDFN 2mm x 2mm package (0.8mm max height).

Applications

Cellular and Cordless Phones
Smartphones and PDAs
MP3 Players
Digital Still Cameras
USB Appliances
Charging Cradles and Docks
Bluetooth® Equipment

Bluetooth is a registered trademark of Bluetooth SIG.

Pin Configuration appears at end of data sheet.



Maxim Integrated Products 1

For pricing, delivery, and ordering information, please contact Maxim Direct at 1-888-629-4642, or visit Maxim's website at www.maxim-ic.com.

Features

- ◆ CCCV, Thermally Regulated Linear 1-Cell Li+ Battery Charger
- ◆ No External MOSFET, Reverse Blocking Diode, or Current-Sense Resistor
- ◆ Programmable Fast-Charge Current (1A_{RMS} max)
- ◆ Proprietary Die Temperature Regulation Control (+115°C)
- ◆ 4.25V to 28V Input Voltage Range with Input OVP Above +7V
- ◆ Charge-Current Monitor for Fuel Gauging (ISET)
- ◆ Low Dropout Voltage (300mV at 500mA)
- ◆ Input Power-Source Detection Output ($\overline{\text{POK}}$), Charge-Enable Input ($\overline{\text{EN}}$)
- ◆ Soft-Start Limits Inrush Current
- ◆ Output for Autobooting (ABO)
- ◆ Tiny 2mm x 2mm, 8-Pin TDFN Package, 0.8mm Height (max)

Ordering Information

PART	TEMP RANGE	PIN-PACKAGE	TOP MARK
MAX8814ETA+	-40°C to +85°C	8 TDFN (2mm x 2mm)	ABI

+Denotes a lead-free and RoHS-compliant package.

Typical Operating Circuit

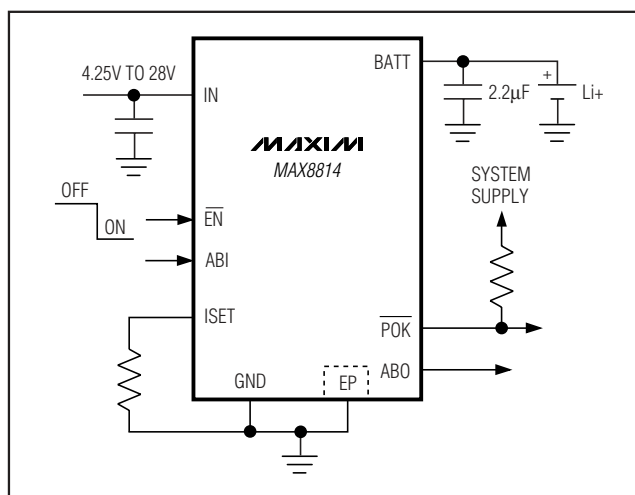

Maxim Integrated Products 1

For pricing, delivery, and ordering information, please contact Maxim Direct at 1-888-629-4642, or visit Maxim's website at www.maxim-ic.com.

28V Linear Li+ Battery Charger with Smart Autoboot Assistant

ABSOLUTE MAXIMUM RATINGS

IN to GND	-0.3V to +30V
ABI, BATT, $\overline{\text{EN}}$, POK to GND	-0.3V to +6V
ABO to GND	-0.3V to ($V_{\text{BATT}} + 0.3\text{V}$)
ISET to GND	-0.3V to +4V
IN to BATT Continuous Current	1A _{RMS}
Continuous Power Dissipation ($T_A = +70^\circ\text{C}$)	
8-Pin TDFN (derate 11.9mW/°C above +70°C)	
(multilayer PCB)	953.5mW

BATT Short-Circuit Duration	Continuous
Operating Temperature Range	-40°C to +85°C
Junction Temperature	+150°C
Storage Temperature Range	-65°C to +150°C
Lead Temperature (soldering, 10s)	+300°C

Stresses beyond those listed under "Absolute Maximum Ratings" may cause permanent damage to the device. These are stress ratings only, and functional operation of the device at these or any other conditions beyond those indicated in the operational sections of the specifications is not implied. Exposure to absolute maximum rating conditions for extended periods may affect device reliability.

ELECTRICAL CHARACTERISTICS

($V_{\text{IN}} = 5\text{V}$, $V_{\text{BATT}} = 4\text{V}$, $R_{\text{POK}} = 1\text{M}\Omega$ to BATT, $\overline{\text{EN}} = 0\text{V}$, $R_{\text{ISET}} = 2.8\text{k}\Omega$ to GND, $C_{\text{BATT}} = 2.2\mu\text{F}$, $T_A = -40^\circ\text{C}$ to $+85^\circ\text{C}$, unless otherwise noted. Typical values are at $T_A = +25^\circ\text{C}$.) (Note 1)

PARAMETER	CONDITIONS		MIN	TYP	MAX	UNITS
Input Voltage Range			0		28	V
Input Operating Voltage Range			4.25		6.80	V
Power-OK Threshold	$V_{\text{IN}} - V_{\text{BATT}}$, 10mV hysteresis (typ)	V_{IN} rising		40		mV
		V_{IN} falling		30		
Overvoltage-Lockout Trip Threshold	V_{IN} rising, 100mV hysteresis (typ)		6.8	7	7.5	V
IN Input Current	Constant-current charging mode ($I_{\text{BATT}} = 0\text{A}$)			0.8	1.35	mA
	IC disabled ($V_{\overline{\text{EN}}} = 5\text{V}$)			0.23	0.50	
	$V_{\text{IN}} = 4\text{V}$, $V_{\text{BATT}} = 4.2\text{V}$	$T_A = +25^\circ\text{C}$		0.021	0.065	
		$T_A = +85^\circ\text{C}$		0.021		
BATT Input Current	$V_{\text{IN}} = 0$ to 4V, $V_{\text{BATT}} = 4.2\text{V}$			1	10	μA
	IC disabled			3		
Battery Regulation Voltage	$I_{\text{BATT}} = 0\text{A}$	$T_A = 0^\circ\text{C}$ to $+85^\circ\text{C}$	4.179	4.200	4.221	V
		$T_A = -40^\circ\text{C}$ to $+85^\circ\text{C}$	4.158	4.200	4.242	
Minimum BATT Bypass Capacitance				2.2		μF
Fast-Charge Current	$V_{\text{BATT}} = 3.5\text{V}$	$T_A = 0^\circ\text{C}$ to $+85^\circ\text{C}$	524	570	616	mA
		$T_A = -40^\circ\text{C}$ to $+85^\circ\text{C}$	485	570	656	
	$V_{\text{BATT}} = 3.5\text{V}$, $R_{\text{ISET}} = 14\text{k}\Omega$	$T_A = 0^\circ\text{C}$ to $+85^\circ\text{C}$	89	107	125	
		$T_A = -40^\circ\text{C}$ to $+85^\circ\text{C}$	80	107	134	
Prequalification Charge Current	Percentage of the fast-charge current, $V_{\text{BATT}} = 2.2\text{V}$, $T_A = 0^\circ\text{C}$ to $+85^\circ\text{C}$		4	10	15	%
Die Temperature Regulation Threshold				+115		$^\circ\text{C}$
V_{BATT} Prequalification Threshold Voltage	V_{BATT} rising, 100mV hysteresis (typ)		2.3	2.5	2.7	V
Current-Sense Amplifier Gain (I_{BATT} to I_{ISET})	$I_{\text{BATT}} = 570\text{mA}$			877.2		$\mu\text{A}/\text{A}$

28V Linear Li+ Battery Charger with Smart Autoboot Assistant

MAX8814

ELECTRICAL CHARACTERISTICS (continued)

($V_{IN} = 5V$, $V_{BATT} = 4V$, $R_{\overline{POK}} = 1M\Omega$ to BATT, $\overline{EN} = 0V$, $R_{ISET} = 2.8k\Omega$ to GND, $C_{BATT} = 2.2\mu F$, $T_A = -40^\circ C$ to $+85^\circ C$, unless otherwise noted. Typical values are at $T_A = +25^\circ C$.) (Note 1)

PARAMETER	CONDITIONS	MIN	TYP	MAX	UNITS
Regulator Dropout Voltage ($V_{IN} - V_{BATT}$)	$V_{BATT} = 4.1V$, $I_{BATT} = 425mA$		240	500	mV
\overline{EN} Logic-Input Low Voltage	$4.25V < V_{IN} < 6.5V$			0.4	V
\overline{EN} Logic-Input High Voltage	$4.25V < V_{IN} < 6.5V$	1.3			V
\overline{EN} and ABI Internal Pulldown Resistance		100	200	400	$k\Omega$
ABI Logic-Input Low Voltage	$V_{IN} = 0V$			0.4	V
ABI Logic-Input High Voltage	$V_{IN} = 0V$	1.3			V
ABO Output Low Voltage	$I_{ABO} (SINK) = 1mA$			0.4	V
ABO Output High Voltage	$I_{ABO} (SOURCE) = 1mA$	$V_{BATT} - 0.4V$			V
\overline{POK} Output Low Voltage	$I_{\overline{POK}} = 5mA$			0.4	V
\overline{POK} Output High Leakage Current	$V_{\overline{POK}} = 5.5V$	$T_A = +25^\circ C$	0.001	1	μA
		$T_A = +85^\circ C$	0.002		

Note 1: Specifications are 100% production tested at $T_A = +25^\circ C$. Limits over the operating temperature range are guaranteed by design and characterization.

Typical Operating Characteristics

($V_{IN} = 5V$, $V_{BATT} = 4V$, $R_{\overline{POK}} = 1M\Omega$ to BATT, $\overline{EN} = 0V$, $R_{ISET} = 2.8k\Omega$ to GND, $C_{BATT} = 2.2\mu F$, $T_A = -40^\circ C$ to $+85^\circ C$, unless otherwise noted. Typical values are at $T_A = +25^\circ C$.)

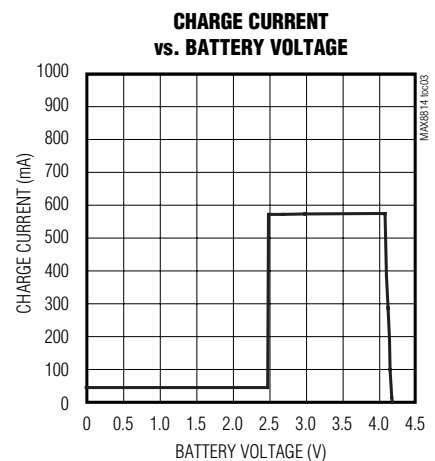
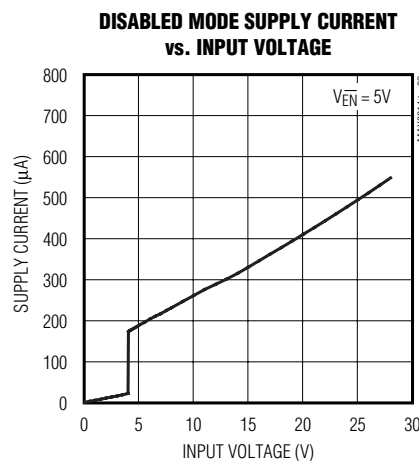
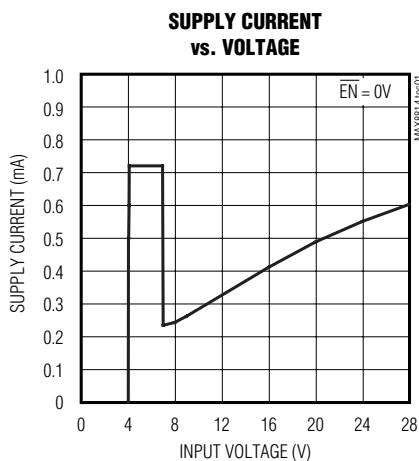

28V Linear Li+ Battery Charger with Smart Autoboot Assistant

Typical Operating Characteristics (continued)

($V_{IN} = 5V$, $V_{BATT} = 4V$, $R_{POK} = 1M\Omega$ to BATT, $\overline{EN} = 0V$, $R_{ISET} = 2.8k\Omega$ to GND, $C_{BATT} = 2.2\mu F$, $T_A = -40^\circ C$ to $+85^\circ C$, unless otherwise noted. Typical values are at $T_A = +25^\circ C$.)

CHARGE CURRENT vs. INPUT VOLTAGE

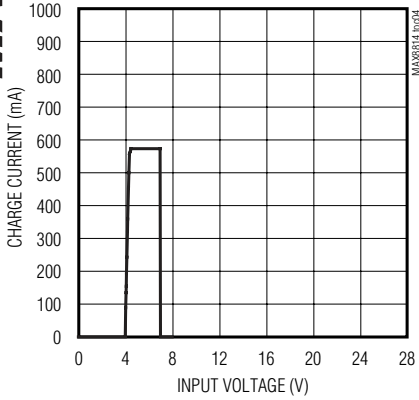

CHARGE CURRENT vs. INPUT VOLTAGE HEADROOM

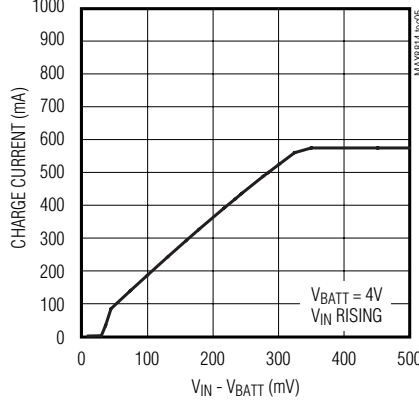

STARTUP INTO PRECHARGE

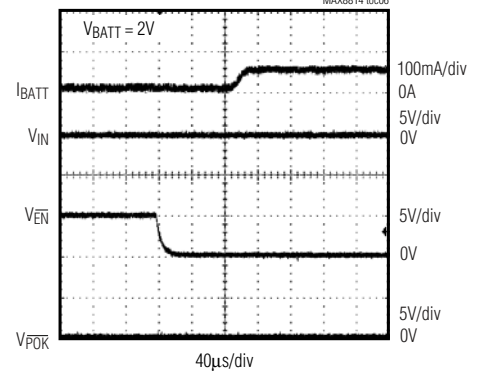

SHUTDOWN (FAST-CHARGE TO SHUTDOWN)

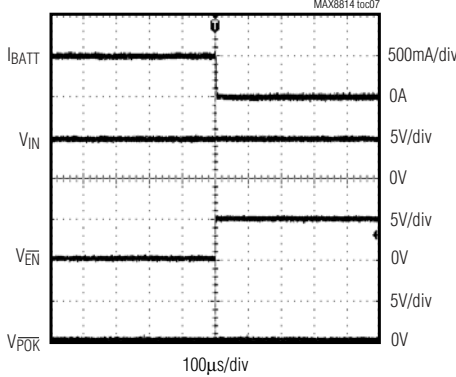

BATTERY REGULATION VOLTAGE ACCURACY vs. AMBIENT TEMPERATURE

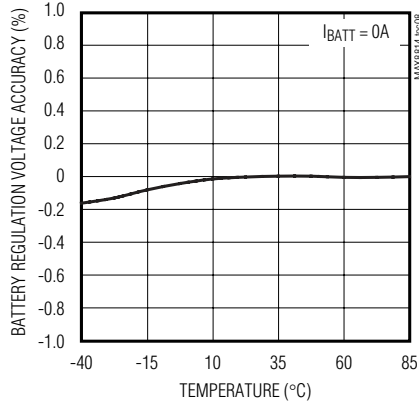

CHARGE CURRENT vs. RISET

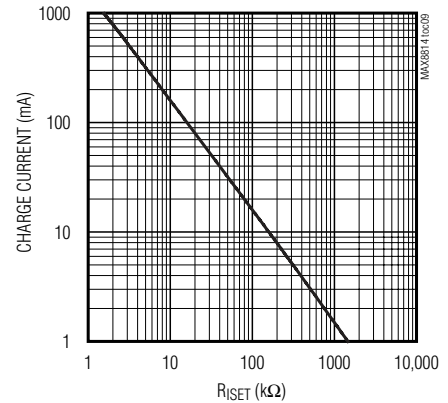

CHARGE CURRENT vs. AMBIENT TEMPERATURE

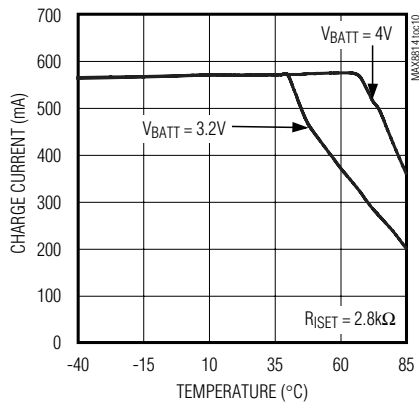

AUTOBOOT ENABLED BY ABI SIGNAL

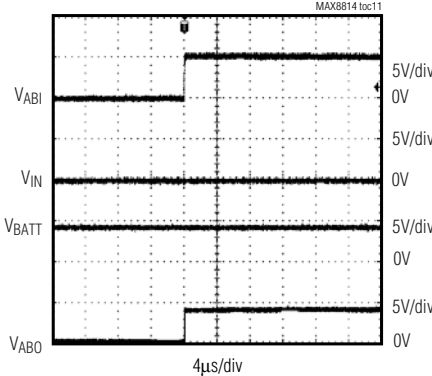

AUTOBOOT ENABLED BY INPUT SUPPLY

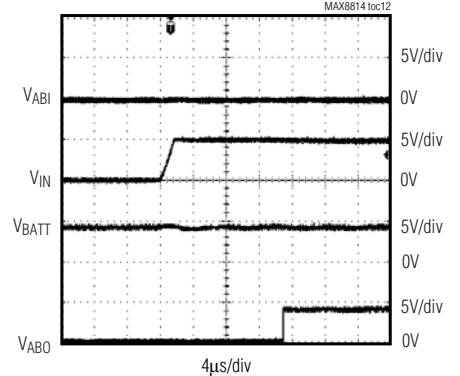

28V Linear Li+ Battery Charger with Smart Autoboot Assistant

Pin Description

MAX8814

PIN	NAME	FUNCTION
1	IN	Input Supply Voltage. Bypass IN to GND with a 1 μ F or larger ceramic capacitor to minimize line noise and maximize input transient rejection.
2	GND	Ground. Connect GND and the exposed paddle to a large copper ground plane for maximum power dissipation. Connect GND to the exposed paddle directly under the IC.
3	ISET	Charge-Current Program and Fast-Charge Current Monitor. Output current from ISET is 877.2 μ A per ampere of battery charging current. Set the charging current by connecting a resistor (R2 in Figure 3) from ISET to GND. $I_{FAST-CHARGE} = 1596V / R_{ISET}$. To configure the MAX8814 as a USB charger, see Figure 4.
4	ABI	Autobooting External Input. See the <i>Autobooting Assistant</i> section and Table 1 for autobooting conditions. ABI is pulled to GND through an internal 200k Ω resistor.
5	ABO	Autobooting Logic Output. See the <i>Autobooting Assistant</i> section and Table 1 for autobooting conditions.
6	\overline{EN}	Logic-Level Enable Input. Drive \overline{EN} high to disable charger. Drive \overline{EN} low or leave unconnected for normal operation. \overline{EN} has an internal 200k Ω pulldown resistor.
7	\overline{POK}	Input-Voltage Status Indicator. Connect a 1M Ω pullup resistor from \overline{POK} to an external system supply. \overline{POK} is an open-drain output that asserts low when $V_{IN} > 4.25V$ and $(V_{IN} - V_{BATT}) \geq 40mV$. If $V_{BATT} \geq (V_{IN} - 40mV)$, the IC is shut down and \overline{POK} becomes high impedance.
8	BATT	Battery Connection. Bypass BATT to GND with a minimum of 2.2 μ F of capacitor.
—	EP	Exposed Paddle. Connect the exposed paddle to a large ground plane for maximum power dissipation. Connect GND to the exposed paddle directly under the IC.

28V Linear Li+ Battery Charger with Smart Autoboot Assistant

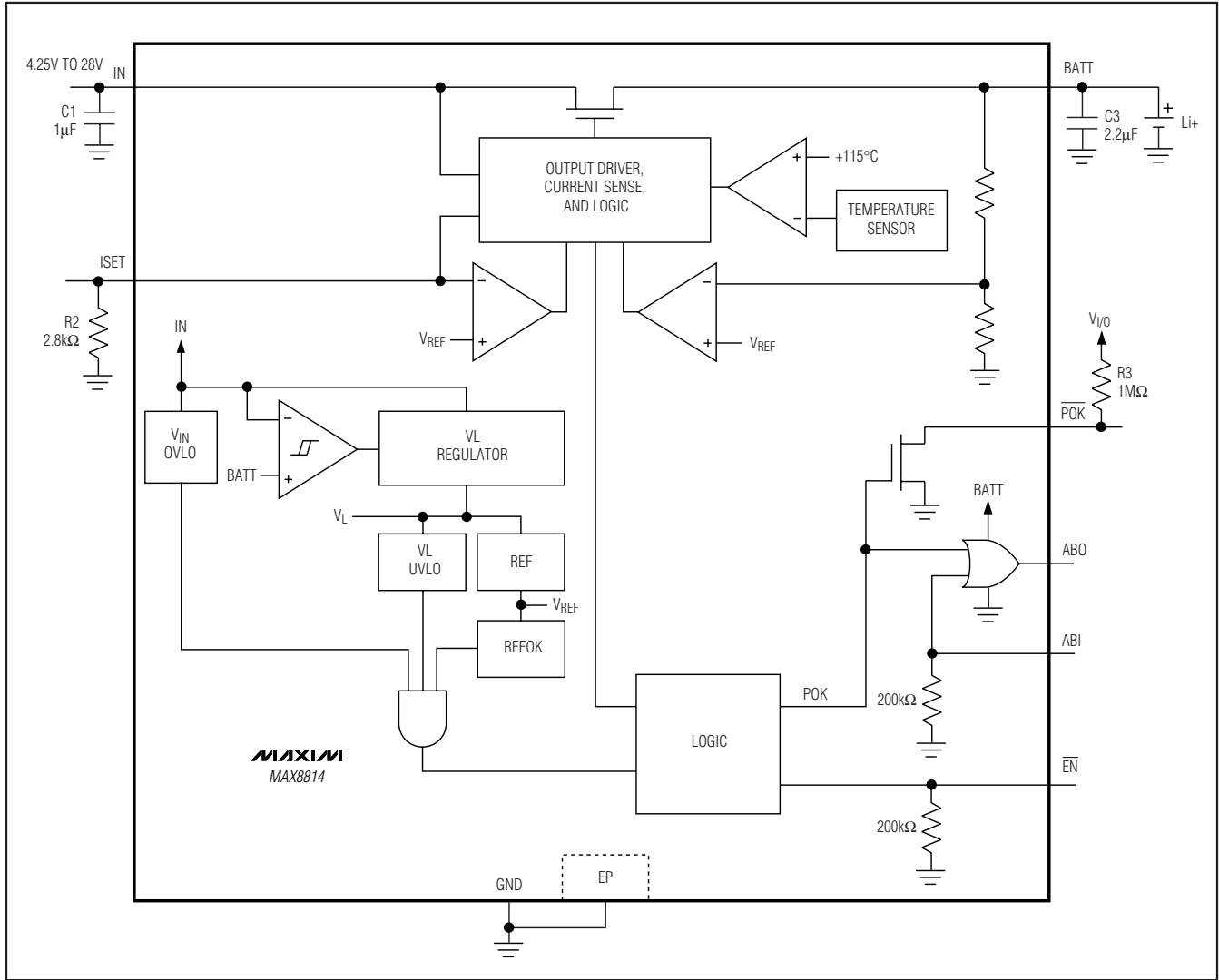

Figure 1. Functional Diagram

Detailed Description

The MAX8814 charger uses voltage, current, and thermal-control loops to charge a single Li+ cell and protect the battery (Figure 1). When a Li+ battery with a cell voltage below 2.5V is inserted, the MAX8814 charger enters the prequalification stage where it precharges that cell with 10% of the user-programmed fast-charge current (Figure 2). When the battery voltage exceeds 2.5V, the charger soft-starts as it enters the fast-charge stage. In the MAX8814, the fast-charge current level is programmed through a resistor from ISET to GND. As the battery voltage approaches 4.2V,

the charging current is reduced. Once the battery voltage reaches 4.2V, the IC then enters a constant voltage regulation mode to maintain the battery at full charge.

Thermal Regulation

The thermal-regulation loop limits the MAX8814 die temperature to +115°C by reducing the charge current as necessary. This feature not only protects the IC from overheating, but also allows a higher charge current without risking damage to the IC.

28V Linear Li+ Battery Charger with Smart Autoboot Assistant

MAX8814

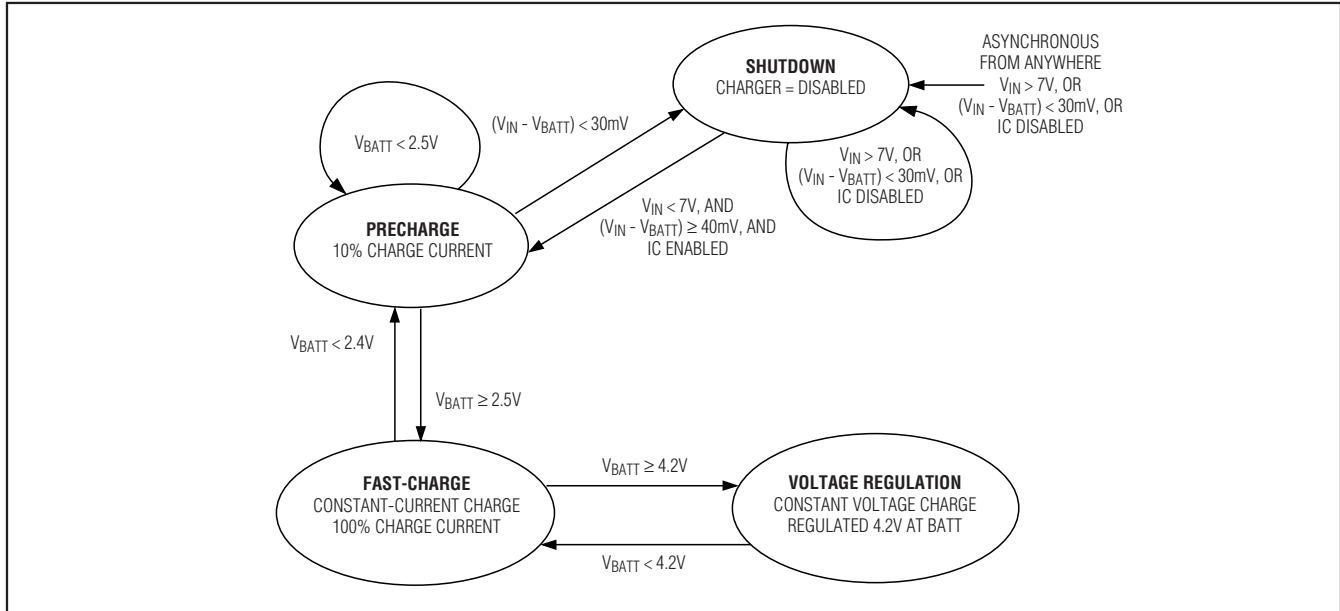

Figure 2. Charge-State Diagram

Charger Enable Input

The MAX8814 contains an active-low logic input ($\overline{\text{EN}}$) used to enable the charger. Drive $\overline{\text{EN}}$ low, leave unconnected, or connect to GND to enable the charger-control circuitry. Drive $\overline{\text{EN}}$ high to disable the charger-control circuitry. $\overline{\text{EN}}$ has an internal 200k Ω pull-down resistor.

$\overline{\text{POK}}$ Output

The open-drain $\overline{\text{POK}}$ output asserts low when $V_{\text{IN}} \geq 4.25\text{V}$ and $(V_{\text{IN}} - V_{\text{BATT}}) \geq 40\text{mV}$ (typ, V_{IN} rising). $\overline{\text{POK}}$ requires an external pullup resistor (1M Ω typ) to an external power supply. $\overline{\text{POK}}$ is high impedance when $V_{\text{BATT}} \geq (V_{\text{IN}} - 40\text{mV})$.

Autobooting Assistant

The MAX8814 contains an autobooting assistant circuit that generates an enable signal for system booting (ABO). The booting assistant functions as an internal “OR” gate (Figure 1). The first input is dependent on the input voltage (V_{IN}), and the second input is an external signal applied to ABI. The first input ($\overline{\text{POK}}$) is driven high once $V_{\text{IN}} \geq 4.25\text{V}$ and $(V_{\text{IN}} - V_{\text{BATT}}) \geq 40\text{mV}$ (typ, V_{IN} rising).

The second input signal (ABI) is driven by an external source. ABI enables an autoboot signal (ABO high) when a battery is connected at BATT and is independent of $\overline{\text{POK}}$. If $\overline{\text{POK}}$ is pulled low, the booting assistant always drives ABO high, regardless of ABI (see Table 1). ABI is pulled to GND through an internal 200k Ω resistor.

Table 1. ABO and $\overline{\text{POK}}$ States

ABI	BATT	$\overline{\text{POK}}$	CHARGER STATE	ABO
Low	Present	Hi-Z	Shutdown	Low
High	Present	Hi-Z	Shutdown	High
X	Not present	Low	Fast-charge/voltage regulation	High
X	Present	Low	Fast-charge/voltage regulation	High

X = Don't care.

If ABI is driven externally, a RC filter (R1 and C2 of Figure 3) is required for ESD protection and noise filtering. If ABI is supplied by a system's internal GPIO, or logic, the RC filter is not required.

Soft-Start

The soft-start algorithm activates when entering fast-charge mode. In the MAX8814, when the prequalification state is complete ($V_{\text{BATT}} \geq 2.5\text{V}$), the charging current ramps up in 250 μs to the full charging current. This reduces the inrush current on the input supply.

28V Linear Li+ Battery Charger with Smart Autoboot Assistant

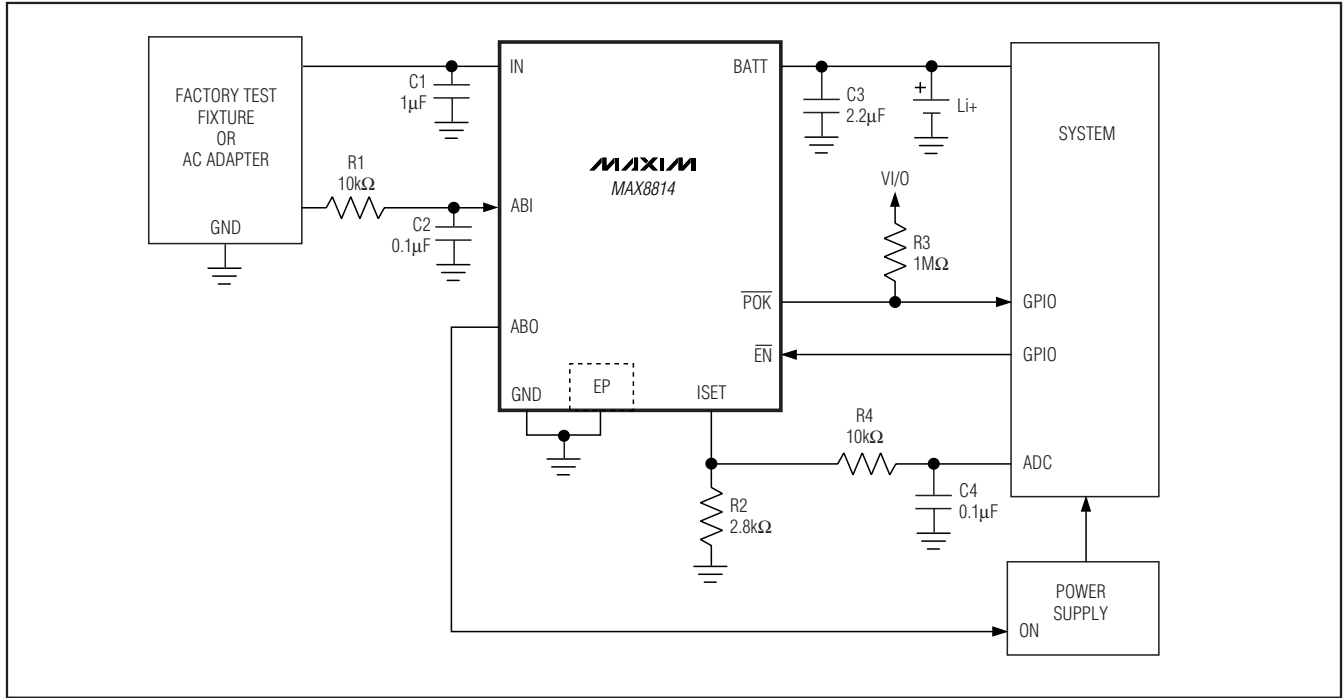

Figure 3. Microprocessor-Interfaced Li+ Battery Charger

Applications Information

Charge-Current Selection

The maximum charging current is programmed by an external resistor connected from ISET to GND (R_{ISET}). Calculate R_{ISET} as follows:

$$R_{ISET} = \frac{1596V}{I_{FAST-CHARGE}}$$

where $I_{FAST-CHARGE}$ is in amperes and R_{ISET} is in ohms. ISET can be used to monitor the fast-charge current level. The output current from ISET is 877.2µA per ampere of charging current. The output voltage at ISET is proportional to the charging current:

$$V_{ISET} = \frac{I_{CHARGE} \times R_{ISET}}{1140}$$

The voltage at ISET is nominally 1.4V at the selected fast-charge current and falls with charging current as the cell becomes fully charged or as the thermal-regulation circuitry activates.

Capacitor Selection

Connect a ceramic capacitor from BATT to GND for proper stability. Use a 2.2µF X5R ceramic capacitor for most applications. Connect a 1µF ceramic capacitor from IN to GND. Use a larger input bypass capacitor for high charging currents to reduce supply noise.

Thermal Considerations

The MAX8814 is available in a thermally enhanced TDFN package with an exposed paddle. Connect the exposed paddle to a large copper ground plane to provide a thermal contact between the device and the circuit board for increased power dissipation. The exposed paddle transfers heat away from the device, allowing the IC to charge the battery with maximum current, while minimizing the increase in die temperature.

DC Input Sources

The MAX8814 operates from a well-regulated DC source. The full charging input voltage range is 4.25V to 7V. The device can withstand up to 28V on the input without damage to the IC. If V_{IN} is greater than 7V, the internal overvoltage-protection circuitry disables charging until the input falls below 7V. An appropriate power supply must provide at least 4.25V at the desired peak charging current.

28V Linear Li+ Battery Charger with Smart Autoboot Assistant

MAX8814

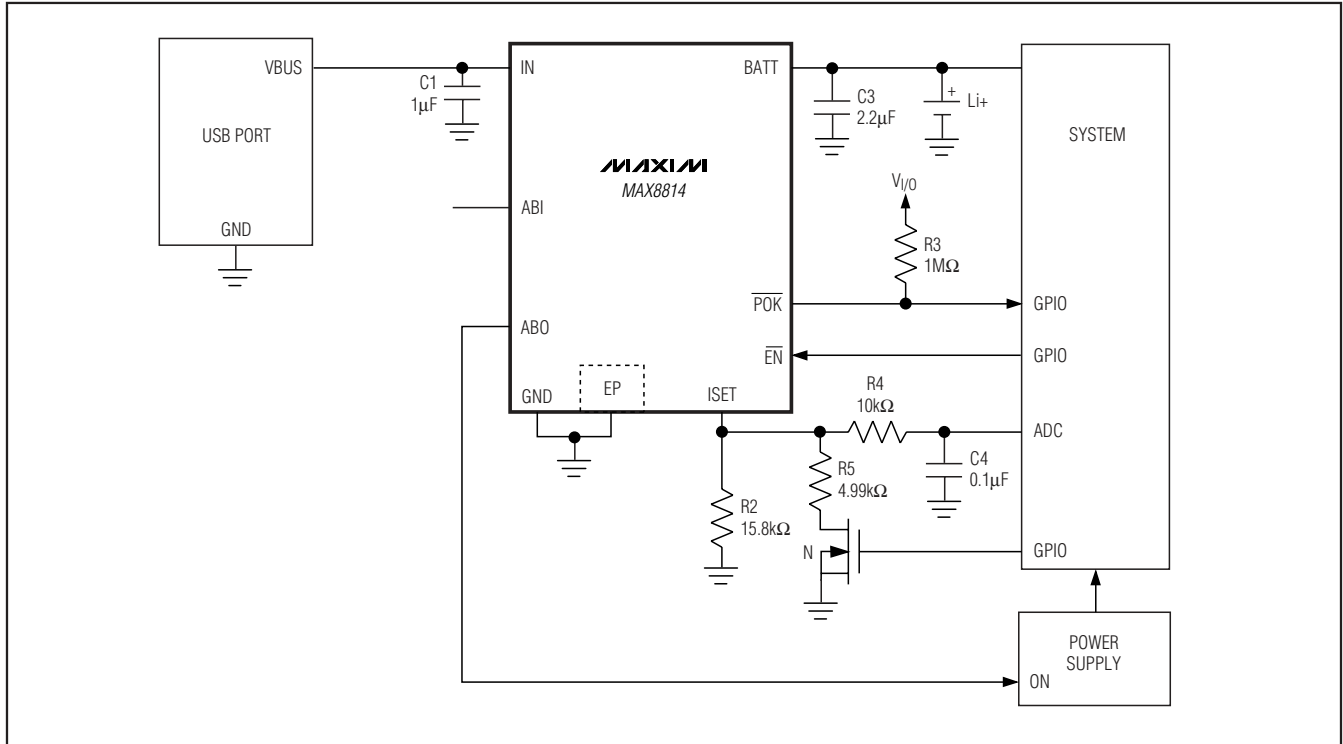

Figure 4. USB Battery Charger

Application Circuits

Microprocessor-Interfaced Charger

Figure 3 shows the MAX8814 as a microprocessor-cooperated Li+ battery charger. The MAX8814 begins charging the battery when \overline{EN} is low. The microprocessor can drive \overline{EN} high to disable the charger. The MAX8814 generates a \overline{POK} signal to indicate the presence of an input supply. By monitoring V_{ISET} , the system can measure the charging current and decide when to terminate the charge.

USB-Powered Li-Ion Charger

The universal serial bus (USB) provides a high-speed serial communication port as well as power for the remote device. The MAX8814 can be configured to charge a battery at the highest current possible from the host port. Figure 4 shows the MAX8814 as a USB battery charger. To make the circuit compatible with either 100mA or 500mA USB ports, the circuit initializes at 100mA charging current. The microprocessor then enumerates the host to determine its current capability. If the host port is capable, the charging current is increased to 425mA to avoid exceeding the 500mA USB specification.

Layout and Bypassing

Place the input and output capacitors as close as possible to the IC. Provide a large copper ground plane to allow the exposed paddle to sink heat away from the IC. Connect the battery to BATT as close as possible to the IC to provide accurate battery voltage sensing. Make all high-current traces short and wide to minimize voltage drops. A sample layout is available in the MAX8814 Evaluation Kit to speed designs.

Chip Information

PROCESS: BiCMOS

28V Linear Li+ Battery Charger with Smart Autoboot Assistant

Pin Configuration

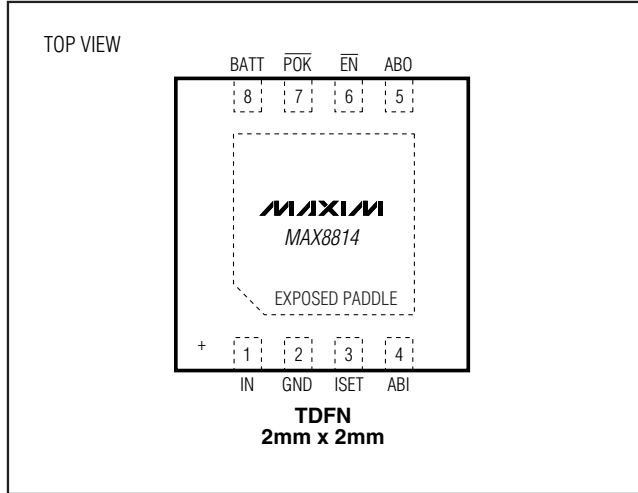

Package Information

For the latest package outline information, go to www.maxim-ic.com/packages.

PACKAGE TYPE	PACKAGE CODE	DOCUMENT NO.
8 TDFN	T822+2	21-0168

28V Linear Li+ Battery Charger with Smart Autoboot Assistant

Revision History

MAX8814

REVISION NUMBER	REVISION DATE	DESCRIPTION	PAGES CHANGED
0	10/07	Initial release	—
1	2/08	Changed OVP (min) to 6.8V from 6.5V with 6 sigma without silicon change	2
2	3/08	Changed Input Operating Voltage maximum range from 6.8V to 6.5V.	1

Maxim cannot assume responsibility for use of any circuitry other than circuitry entirely embodied in a Maxim product. No circuit patent licenses are implied. Maxim reserves the right to change the circuitry and specifications without notice at any time.

Maxim Integrated Products, 120 San Gabriel Drive, Sunnyvale, CA 94086 408-737-7600 _____ 11