

# TA SERIES

## Lockout

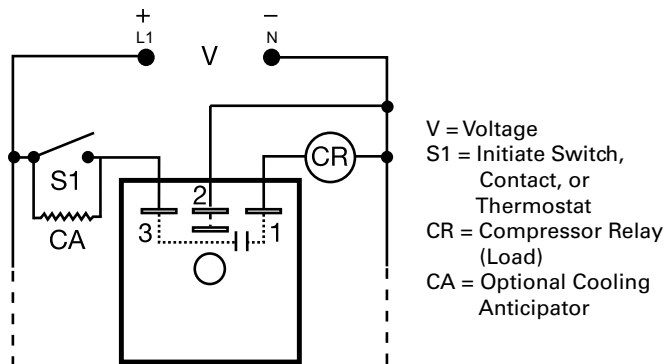

### Wiring Diagram



### Description

The TA Series prevents rapid recycling of a compressor. A lockout delay is started when the thermostat opens, or input voltage is lost. Eliminates tripped circuit breakers or blown fuses caused by a locked rotor during short cycling. The TA will not allow the compressor to start when the line voltage is low. Chatter of the compressor relay is eliminated. Because of the fast initiate time, bounce of the thermostat will not be transmitted to the compressor relay coil. A 30 second delay provides anti-reversing protection for scroll compressors.

#### Operation (Lockout)

On initial closure of the S1, the compressor relay energizes immediately. When S1 opens or input voltage is interrupted, a lockout time delay is initiated. During this lockout time delay, the compressor relay cannot be energized. The low voltage (brownout) protection prevents energization of the compressor when the line voltage is low.

**Reset:** The lockout time delay cannot be reset. After the time delay is completed, the unit automatically resets.

### Features & Benefits

FEATURES	BENEFITS
<b>Lockout delay</b>	Prevents rapid cycling of compressor and eliminates nuisance service calls due to blown fuse or tripped breaker by locked rotor during short cycling
<b>Anti-reversing protection for scroll compressors</b>	Extends life of equipment
<b>Brownout protection</b>	Timer will not allow the compressor to start during low line voltage conditions
<b>Encapsulated</b>	Protects against shock, vibration, and humidity
<b>1A solid state output</b>	No moving parts to arc and wear out. Provides up to 100 million operations under typical conditions

### Accessories



#### P1023-6 Mounting bracket

The 90° orientation of mounting slots makes installation/removal of modules quick and easy.



#### P1015-64 (AWG 14/16) Female Quick Connect

These 0.25 in. (6.35 mm) female terminals are constructed with an insulator barrel to provide strain relief.



#### P1015-18 Quick Connect to Screw Adapter

Screw adapter terminal designed for use with all modules with 0.25 in. (6.35 mm) male quick connect terminals.



#### C103PM (AL) DIN Rail

35 mm aluminum DIN rail available in a 36 in. (91.4 cm) length.



#### P1023-20 DIN Rail Adapter

Allows module to be mounted on a 35 mm DIN type rail with two #10 screws.

### Ordering Information

MODEL	INPUT VOLTAGE	TIME DELAY
TA12D1	12VDC	1m
TA12D2	12VDC	2m
TA24A0.5	24VAC	30s
TA24A3	24VAC	3m
TA24A5	24VAC	5m

If you don't find the part you need, call us for a custom product 800-843-8848

## TA SERIES

### Specifications

<b>Input</b>	
<b>Voltage</b>	12 or 24VDC; 24VAC
<b>AC Line Frequency</b>	50/60 Hz
<b>Impedance</b>	450 $\Omega$ (anticipator by-pass)
<b>Output</b>	
<b>Minimum Load Current</b>	75mA
<b>Maximum Load Current</b>	1A at 60°C
<b>Voltage Drop</b>	$\leq$ 1.25V
<b>Time Delay</b>	
<b>Initiate Time</b>	$\approx$ 16ms
<b>Lockout Time</b>	Fixed 0.5, 1, 2, 3, or 5m
<b>Tolerance</b>	-15% - 35%
<b>Protection</b>	
<b>Circuitry</b>	Encapsulated
<b>Low Voltage Protection</b>	$\approx$ 20V: 24VAC/DC; $\approx$ 9V: 12VDC
<b>Dielectric Breakdown</b>	$\geq$ 2000V RMS terminals to mounting surface
<b>Insulation Resistance</b>	$\geq$ 100 M $\Omega$

### Mechanical

#### Mounting Dimensions

Surface mount with one #10 (M5 x 0.8) screw  
**H** 50.8 mm (2"); **W** 50.8 mm (2");  
**D** 30.7 mm (1.21")  
 0.25 in. (6.35 mm) male quick connect terminals

#### Termination

### Environmental

#### Operating/Storage

-40° to 70°C / -40° to 85°C

#### Temperature

#### Humidity

95% relative, non-condensing

#### Weight

$\approx$  2.4 oz (68 g)

#### Thermostat

**Cooling Anticipator Resistor**  $\geq$  1800  $\Omega$

### Function Diagram

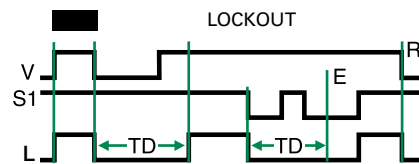

V = Voltage  
 S1 = Initiate Switch  
 L = Load (CR)  
 E = Ready  
 TD = Time Delay  
 R = Reset