

# OV9752 720p HD product brief



## High Performance CameraChip™ Sensor with RGB-IR Color Filter for Advanced Security Applications



available in  
a lead-free  
package

OmniVision's OV9752 CameraChip™ captures high quality (HD) images and video in 1280 x 960 pixel resolution as well as infrared information, providing excellent scene reproduction regardless of lighting conditions. These benefits make the OV9752 an ideal camera solution for security systems designed to record during day and night.

The OV9752 replaces the traditional mechanical rotary filter with an RGB-IR dual band color filter to simplify design, reduce package footprint, and capture extremely high quality infrared images and video.

Built on the 3.75-micron OmniPixel3-HS™ pixel architecture, the OV9752 delivers excellent results whether recording visible light or infrared, capturing

clear images and video in high, low, and "no" light environments. The sensors can capture in 1280 x 960 pixel resolution video at 60 frames per second (fps) with 10-bit output, or at 45 fps with 12-bit output. Additionally, the OV9752 features an ultra-low power mode, which allows the sensor to reduce the resolution and frame rates, thus further reducing power consumption.

The OV9752 fits into a 6.3 x 5.2 mm package.

Find out more at [www.ovt.com](http://www.ovt.com).



## Applications

- Security and Surveillance Cameras
- Wearables
- PC Multimedia
- 960H for Analog CCTV Applications

## Product Features

- RGB-IR color filter
- 3.75  $\mu\text{m}$  x 3.75  $\mu\text{m}$  pixel
- 1280x960 at 60 fps @ 10-bit, 45 fps @ 12-bit
- programmable controls for frame rate, mirror and flip, cropping, and windowing
- supports images sizes: SXGA (1280 x 960), VGA (640 x 480), and more
- 2k bits of embedded one-time programmable (OTP) memory
- ultra low power mode (ULPM)
- support for output formats: 10/12-bit RGB-IR RAW
- two-wire serial bus control (SCCB)
- MIPI serial output interface (1- or 2-lane) / DVP interface
- 2x binning support
- image quality control: defect pixel correction and automatic black level calibration

# OV9752



## Ordering Information

- OV09752-H55A (RGB-IR, lead-free, 55-pin CSP5)

## Product Specifications

- active array size: 1280 x 960
- power supply:
  - core: 1.7 to 1.9V (1.8V nominal)
  - analog: 3.15 to 3.45V (3.3V nominal)
  - I/O: 1.7 to 1.9V (1.8V nominal)
- power requirements:
  - active: 165 mW
- temperature range:
  - operating: -30°C to +85°C junction temperature
  - stable image: 0°C to +60°C junction temperature
- output interface: 2-lane MIPI serial output / DVP parallel output
- output formats: 10/12-bit RGB-IR RAW
- lens size: 1/3"
- lens chief ray angle: 9° linear
- input clock frequency: 6 - 74.5 MHz
- maximum image transfer rate:
  - SXGA (1280x960): 60 fps
  - VGA (640x480): 120 fps
- pixel size: 3.75  $\mu\text{m}$  x 3.75  $\mu\text{m}$
- image area: 4860  $\mu\text{m}$  x 3660  $\mu\text{m}$
- die dimensions: 6254  $\mu\text{m}$  x 5194  $\mu\text{m}$

## Functional Block Diagram

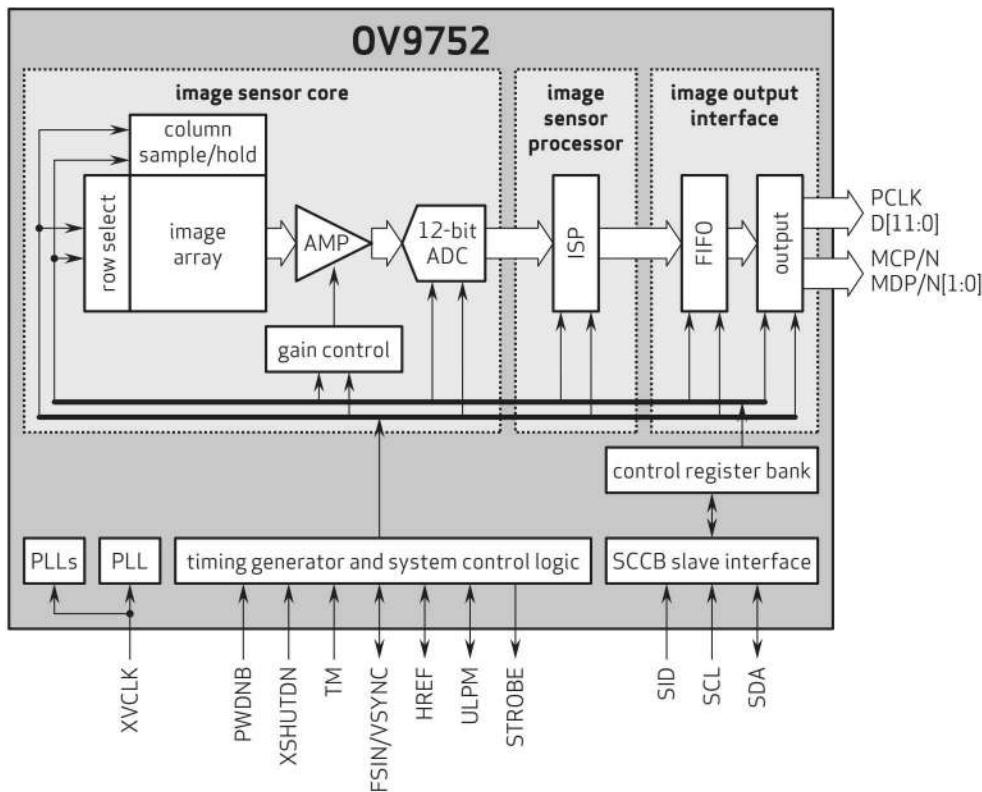

4275 Burton Drive  
Santa Clara, CA 95054  
USA

Tel: +1 408 567 3000  
Fax: +1 408 567 3001  
www.ovt.com

OmniVision reserves the right to make changes to their products or to discontinue any product or service without further notice. OmniVision, the OmniVision logo and OmniPixel are registered trademarks of OmniVision Technologies, Inc. OmniPixel3-HS is a trademark of OmniVision Technologies, Inc. All other trademarks are the property of their respective owners.



OmniVision