

THIS DOCUMENT IS THE PROPERTY OF KEYSTONE ELECTRONICS CORP. AND SHALL NOT BE REPRODUCED, DISTRIBUTED OR USED AS A BASIS FOR MANUFACTURE WITHOUT PRIOR WRITTEN PERMISSION FROM KEYSTONE ELECTRONICS CORP.

**ACTUAL SIZE**

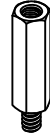

P/N 24309

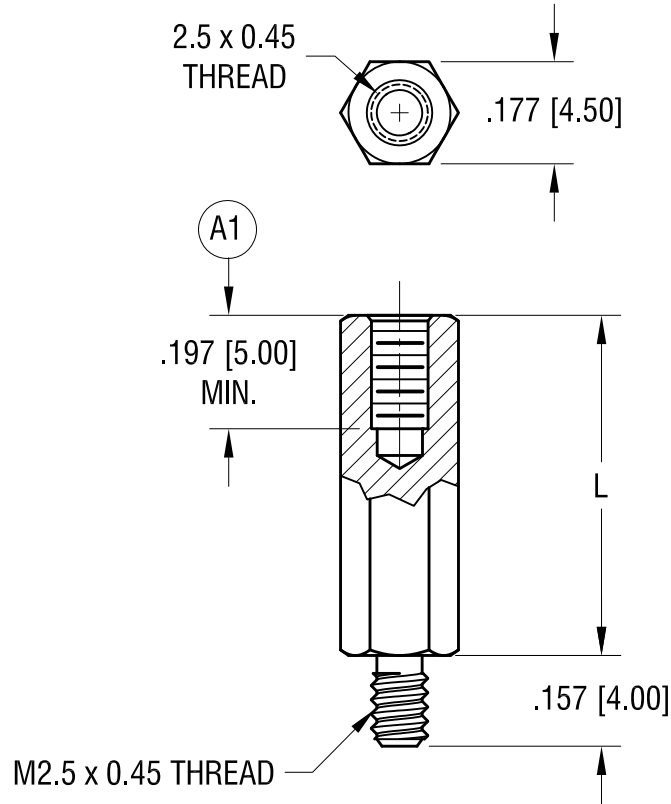

PART NO.	'L' DIM.
24307	.394 [10.00]
24308	.472 [12.00]
24309	.591 [15.00]
24310	.709 [18.00]
24311	.788 [20.00]
24312	.984 [25.00]

**KEYSTONE ELECTRONICS CORP.**  
 www.keyelco.com • NEW HYDE PARK NY 11040 • Tel (516)328-7500

PART NAME: 4.5 mm HEX M/F STANDOFF

MATERIAL: BRASS

FINISH: NICKEL PLATE

DRN BY: BOONE DATE: 5.08.06  
 APP'D: RH SCALE: 3X

TOLERANCES INCH [MM]  
 DECIMAL ± .005 [± 0.13]  
 ANGULAR ± 1°  
 UNLESS OTHERWISE SPECIFIED

CODE: C DWG NO. 24307-24312

9.20.22	(A1) WAS 5mm±0.80mm CHANGE AS PER ECN 22-149	A
DATE	DESCRIPTION	REV.