

M1 Series

5x7 mm, 5.0 Volt, HCMOS/TTL Compatible Output, Clock Oscillator

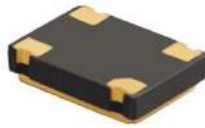

Features:

- Leadless Chip Carrier (LCC) package
- Seam sealed package
- Tri-state function option
- Stabilities to ± 20 ppm
- Fully RoHS 6 compliant

Applications:

- Microprocessors/Controllers, DSP
- Gig E, SONET
- Industrial Controllers
- Broadband Access
- Test & Measurement Equipment

Ordering Information

00.0000
MHz

Product Series M1 1 3 F A N

Temperature Range
 1: 0°C to +70°C 2: -40°C to +85°C
 4: -55°C to +125°C 6: -20°C to +70°C

Stability
 3: ± 100 ppm 4: ± 50 ppm
 5: ± 35 ppm 6: ± 25 ppm
 *8: ± 20 ppm

Output Type
 F: Fixed T: Tristate

Symmetry/Logic Compatibility
 A: 40/60 TTL/HCMOS (50.000 MHz and below)
 C: 45/55 HCMOS
 G: 40/60 HCMOS (50.001 to 125.000 MHz)

Package/Lead Configurations
 N: Leadless Ceramic

Frequency (customer specified)

*Contact Factory for Availability
M2010Sxxx - Contact factory for datasheet.

PARAMETER	Symbol	Min.	Typ.	Max.	Units	Condition/Notes
Frequency Range	F	1.5		125	MHz	See Note 1
Operating Temperature	T _A	(See ordering information)				
Storage Temperature	T _s	-55		+125	°C	
Frequency Stability	$\Delta F/F$	(See ordering information)				
Aging 1 st Year Thereafter (per year)			± 3 ± 2		ppm ppm	
Input Voltage	V _{dd}	4.5	5.0	5.5	V	
Input Current	I _{dd}			20 35/45 65	mA mA mA	1.5000 to 20.000 MHz 20.001 to 60.000 MHz 50.001 to 125.000 MHz
Output Type						HCMOS/TTL Compatible
Load 1.500 to 50 MHz 50.001 to 67 MHz 67.001 to 125 MHz				50/10 50 15	pF/TTL pF pF	See Note 2
Symmetry (Duty Cycle)		(See ordering information)				1/2 V _{dd}
Logic "1" Level	V _{oh}	90% V _{dd} V _{dd} - 0.5			V V	HCMOS Load TTL Load
Logic "0" Level	V _{ol}			10% V _{dd} 0.5	V V	HCMOS Load TTL Load
Output Current				± 16	mA	
Rise/Fall Time	T _r /T _f			10 3	ns ns	See Note 3 1.5000 to 67.000 MHz 67.001 to 125.000 MHz
Tristate Function		Input Logic "1" or floating; output active Input Logic "0"; output disables to high-Z				
Start up Time				10	ms	
Random Jitter	R _j		5	12	ps RMS	1-Sigma
Mechanical Shock	Per MIL-STD-202, Method 213, Condition C (100 g's, 6 ms duration, 1/2 sinewave)					
Vibration	Per MIL-STD-202, Method 201 & 204 (10 g's from 10-2000 Hz)					
Hermeticity	Per MIL-STD-202, Method 112, (1x10 ⁻⁸ atm. cc/s of Helium)					
Thermal Cycle	Per MIL-STD-883, Method 1010, Condition B (-55°C to +125°C, 15 min. dwell, 10 cycles)					
Solderability	Per EIAJ-STD-002					
Max Soldering Conditions	See solder profile, Figure 1					

1. Consult factory for availability of higher frequencies.
2. HCMOS Load - See Load circuit diagram. Consult factory with nonstandard output load requirements.
3. Rise/Fall times are measured between 0.5 V and 2.4 V with TTL load, and between 10% V_{dd} and 90% V_{dd} with HCMOS load.

MtronPTI reserves the right to make changes to the product(s) and service(s) described herein without notice. No liability is assumed as a result of their use or application.

Please see www.mtronpti.com for our complete offering and detailed datasheets. Contact us for your application specific requirements: MtronPTI 1-800-762-8800.

M1 Series

5x7 mm, 5.0 Volt, HCMOS/TTL Compatible Output, Clock Oscillator

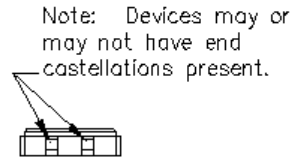
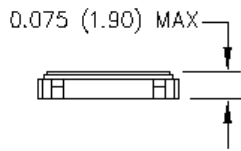
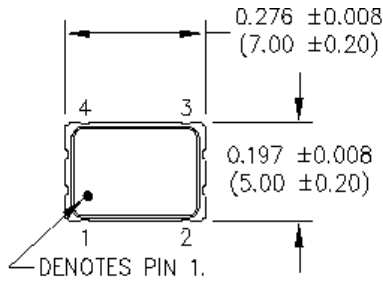

All dimensions in inches (mm).

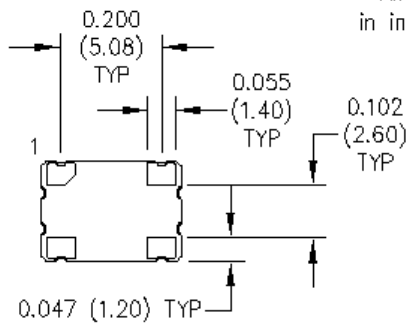

SUGGESTED SOLDER PAD LAYOUT

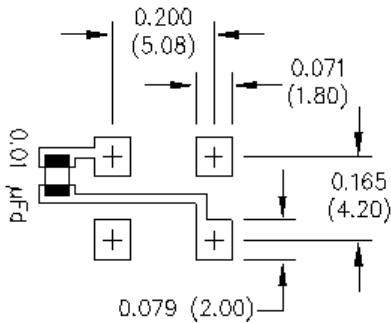

Pin Connections	
PIN	Function
1	N/C or Tristate
2	Ground
3	Output
4	+Vdd

Load Circuit Diagram

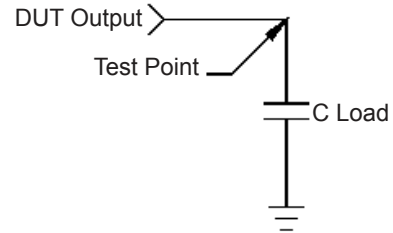

Note: C Load includes probe and fixturing.

MtronPTI Lead Free Solder Profile

