

PRODUCT NUMBER
SEE TABLE

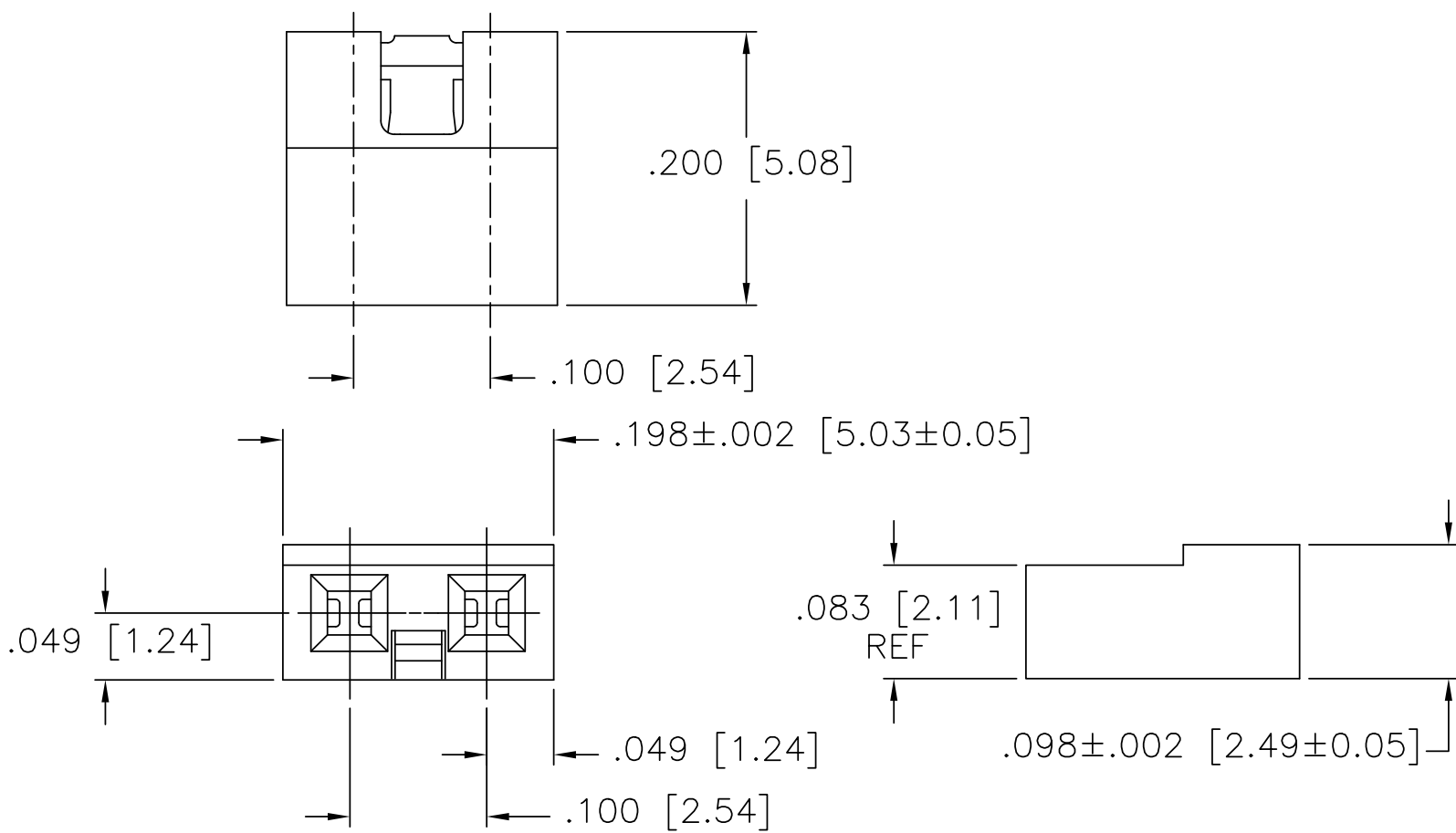

mat'l. code		surface ISO 1302 ✓		tolerance ISO 406 ISO 1101		projection ⊕		product family JUMPER	
ltr ecn nqdr date		tolerances unless otherwise specified		title		1X2 LOW PROFILE JUMPER ASSEMBLY			
S	BLX-N-011711	JZ	2012-05-04	angles	linear	INCH/MM		dwg no	
L	M05-0205	ERE	9/30/05	0°±2'		scale 1:1		sheet of 2	
M	M06-0238	MN	6/16/06	dr	R.EBY	10/07/87		size	
N	M06-0389	AGS	10/4/06	engr	M.HAHN	10/07/87		A3	
P	M08-0209	MHT	7/18/08	chr	M.HAHN	10/07/87		68786	
R	M09-0065	MHT	4/13/09	appd	M.HAHN	10/07/87		type Product Customer Drawing	
sheet	revisions	S	S						
index	sheet	1	2						



Copyright FCI

PRODUCT No.	CONTACT PLATING	HSG COLOR	LEAD FREE
68786-102	15u"/.38u Au OR GXT OVER 50u"/1.27u Ni	WHITE	NOTE 4
-202	30u"/.76u Au OR GXT OVER 50u"/1.27u Ni	WHITE	
-302	100u"/2.54u Sn	WHITE	
-402	Au FLASH OVER 50u"/1.27u Ni	BLACK	
-103	15u"/.38u Au OR GXT	BLUE	
-203	30u"/.76u Au OR GXT	BLUE	
-303	100u"/2.54u Sn	BLUE	
-403	Au FLASH OVER 50u"/1.27u Ni	BLUE	
-802	SAME AS -202 EXCEPT ADD SPECIAL MIL MARKING		
68786-204	30u"/.76u Au OR GXT OVER 50u"/1.27u Ni	YELLOW	
68786-304	100u"/2.54u Sn	YELLOW	

OBSOLETE
OBSOLETE
OBSOLETE

NOTES:

- ① MATERIAL: POLYESTER, FLAME RETARDANT PER UL-94-V0 .
2. RECOMMENDED APPLICATION DATA:
 - A. ALL MATING PINS TO BE .025/.64 SQ ON TRUE CENTERS OF GIVEN TERMINAL SPACING WITHIN .015/.38 DIA .
 - B. SUGGESTED MATING PIN LENGTH .160/4.06 MIN .
- ③ ADD "LF" SUFFIX AT THE END OF PART NUMBER FOR LEAD FREE OPTION.
4. THIS PRODUCT MEETS EUROPEAN UNION DIRECTIVES AND OTHER COUNTRY REGULATION AS DESCRIBED IN GS-22-008.
5. THIS PRODUCT IS NOT INTENDED TO BE EXPOSED TO A MANUFACTURING SOLDER PROCESS.
6. PRODUCT SPECIFICATION: BUS-12-071.

mat'l. code		surface ISO 1302 ✓	tolerance ISO 406 ISO 1101	projection 	product family JUMPER
l	tr	ec	n	o	d
date		tolerances unless otherwise specified		title	
s		linear	linear	INCH/MM	
		0±2'		scale 1:1	
		dr	R.EBY	10/07/87	
		engr	M.HAHN	10/07/87	
		chr	M.HAHN	10/07/87	
		appd	M.HAHN	10/07/87	
sheet index		revision sheet			

FCJ
dwg no 68786
sheet 2 of 2
size A3
type Product Customer Drawing

Copyright FCI
FCIconnect.com