

REVISIONS

P	LTR	DESCRIPTION	DATE	DWN	APVD
N9	3-	-3 AND 3- -4 PARTS ADDED	25NOV2021	SCB	SS

NOTES:

MATERIAL:

HOUSING: THERMOPLASTIC PA, UL94V-0, BLACK.  
 TERMINAL: BRIGHT TIN PLATED, COPPER ALLOY.  
 SCREW: 6-32, STEEL, ZINC PLATED CLEAR CHROMATE.

ELECTRICAL:

UL CLASS C: 20A, 150V.  
 UL CLASS D: 10A, 300V.  
 CSA TYPE B: 20A, 300V.  
 CSA TYPE C: 20A, 300V.  
 CSA TYPE D: 10A, 300V.  
 CSA TYPE E: 20A, 300V.  
 WIRE RANGE: 12-22 AWG

MECHANICAL:

MAXIMUM TORQUE RATING: 7 IN-LBS.  
 RUNNING TORQUE: 0.5-3.5 IN-LBS UNLESS OTHERWISE STATED.

- 1 SCREWS ARE BOTTOMED, NO THREAD INTERRUPT.
- 2 SCREWS ARE NICKEL PLATED BRASS.
- 3 SCREWS ARE CAPTIVE.
- 4 SEE FIGURE.
- 5 PRELIMINARY PART NUMBER.
- 6 OBSOLETE PARTS: OBSOLETE CIS STREAMLINING PER D.RENAUD/D.SINISI
- 7 TERMINAL FINISH: MATTE TIN
- 8 OBSOLETE
- 9 SCREWS ARE IN TIGHTENED CONDITION

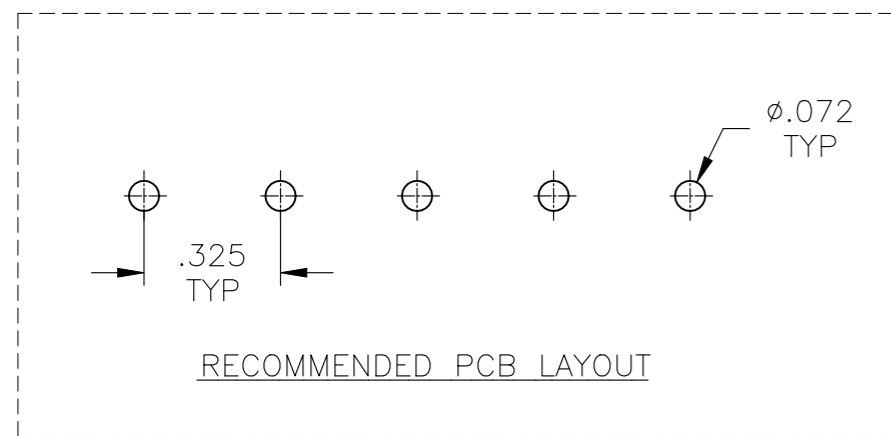
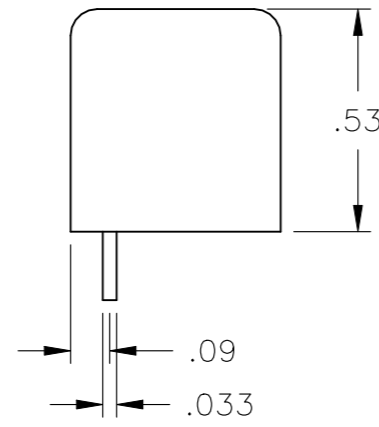
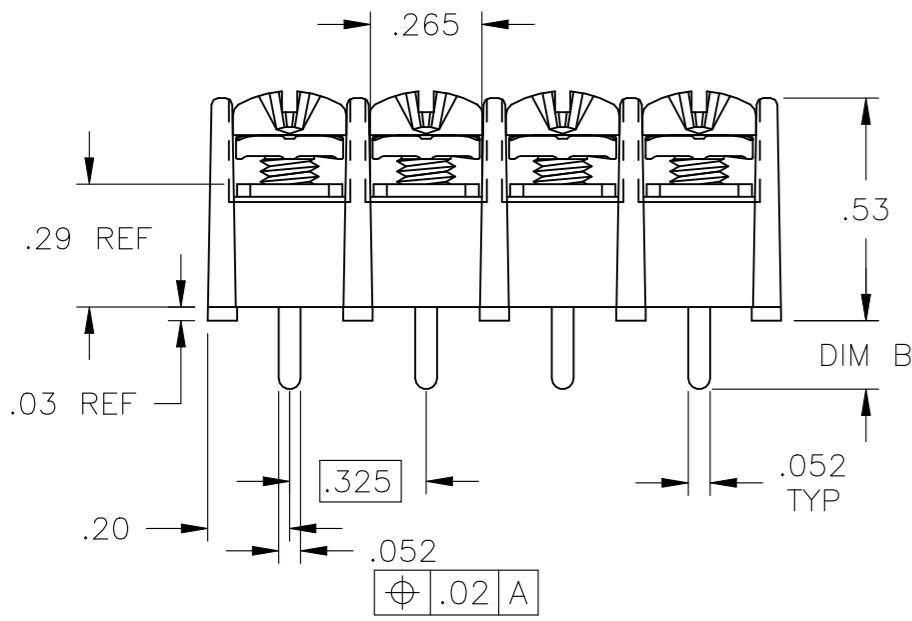
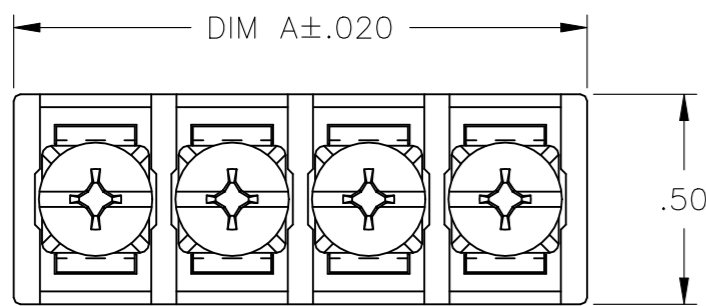

3-796658-3 AS SHOWN

3-796658-4 AS SOWN

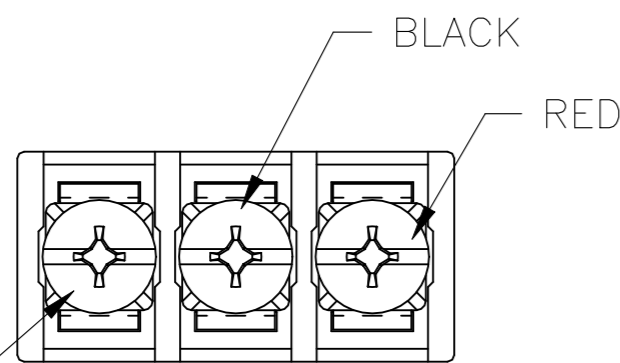

2-796658-9

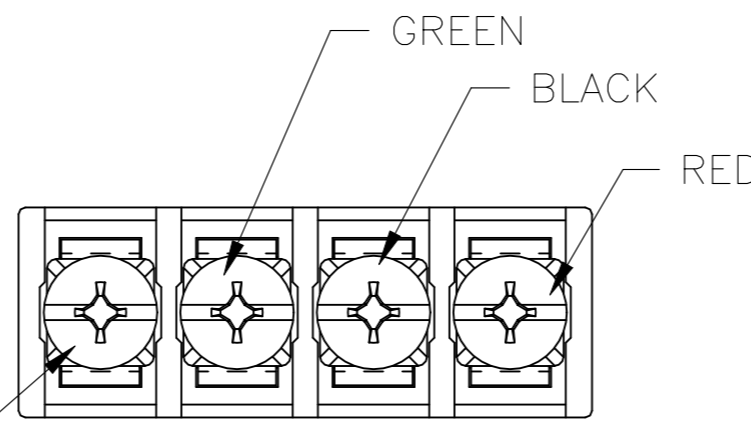

3-796658-0

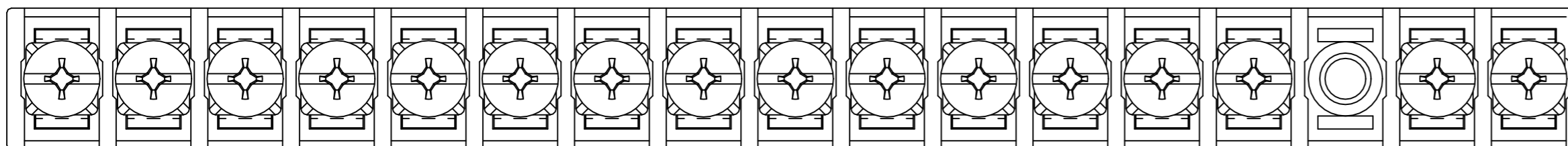

2-796658-4

DIM B	CATALOG NUMBER	DIM A	NO OF POS.	PART NUMBER
.160	4DB-P108-05-SPCL	1.690	5	3-796658-4
.160	4DB-P108-03-SPCL	1.040	3	3-796658-3
.160	4DB-P108-04-SPCL	1.365	4	3-796658-0
.160	4DB-P108-03-SPCL	1.040	3	2-796658-9
.160	4DB-P108-30	9.815	30	5-1437667-5
.160	4DB-P108-29	9.490	29	796658-9
.160	4DB-P108-28	9.165	28	5-1437667-3
.160	4DB-P108-27	8.840	27	796658-8
.160	4DB-P108-26	8.515	26	5-1437667-2
.160	4DB-P108-25	8.190	25	796658-7
.160	4DB-P108-24	7.865	24	5-1437667-0
.160	4DB-P108-23	7.540	23	796658-6
.160	4DB-P108-22	7.215	22	4-1437667-8
.160	4DB-P108-21	6.890	21	796658-2
.160	4DB-P108-20	6.565	20	4-1437667-6
.160	4DB-P108-19	6.240	19	4-1437667-5
.160	4DB-P108-18	5.915	18	4-1437667-4
.160	4DB-P108-16-105	5.590	17	2-796628-4
.160	4DB-P108-17	5.590	17	4-1437667-2
.160	4DB-P108-16	5.265	16	4-1437667-0
.160	4DB-P108-15	4.940	15	3-1437667-9
.160	4DB-P108-14-102	4.615	14	2-796658-5
.160	4DB-P108-14-102	4.615	14	2-796658-3
.160	4DB-P108-14	4.615	14	3-1437667-8
.160	4DB-P108-13	4.290	13	3-1437667-7
.160	4DB-P108-12	3.965	12	3-1437667-6
.160	4DB-P108-11	3.640	11	3-1437667-5
.160	4DB-P108-10	3.315	10	3-1437667-3
.160	4DB-P106-09-094	2.990	9	1-796658-7
.160	4DB-P108-09	2.990	9	3-1437667-2
.160	4DB-P108-08-091	2.665	8	1-796658-4
.160	4DB-P108-08	2.665	8	3-1437667-1
.160	4DB-P106-07-100	2.340	7	2-796658-2
.160	4DB-P106-07-093	2.340	7	1-796658-6
.160	4DB-P108-07	2.340	7	3-1437667-0
.160	4DB-P106-06-099	2.015	6	2-796658-1
.160	4DB-P108-06-090	2.015	6	1-796658-3
.200	4DB-P108-06	2.015	6	2-796658-6
.160	4DB-P108-06	2.015	6	2-1437667-9
.160	4DB-P106-05-098	1.690	5	2-796658-0
.160	4DB-P108-05-093	1.690	5	1-796658-5
.160	4DB-P108-05	1.690	5	2-1437667-8
.160	4DB-P106-04-097	1.365	4	1-796658-9
.160	4DB-P108-04-089	1.365	4	1-796658-2
.160	4DB-P108-04	1.365	4	2-1437667-6
.160	4DB-P106-03-096	1.040	3	1-796658-8
.160	4DB-P108-03-088	1.040	3	1-796658-1
.160	4DB-P108-03	1.040	3	2-1437667-5
.142	4DB-P108-02-143	.715	2	2-796658-8
.142	4DB-P108-02-142	.715	2	2-796658-7
.160	4DB-P108-02	.715	2	2-1437667-4

THIS DRAWING IS A CONTROLLED DOCUMENT. 01MAY2003

DWN S WELDON 5/1/03  
 CHK S YODER 5/1/03  
 APVD S YODER 5/1/03

TE Connectivity  
 ASSEMBLY, DUAL BARRIER  
 4DB P108 XX

SIZE A2 CAGE CODE 00779 DRAWING NO C=2-1437667-4 RESTRICTED TO -  
 WEIGHT - APPLICATION SPEC -  
 MATERIAL - FINISH - WEIGHT - SCALE NTS SHEET 1 OF 1 REV N9