

PRODUCT NO
SEE TABLE

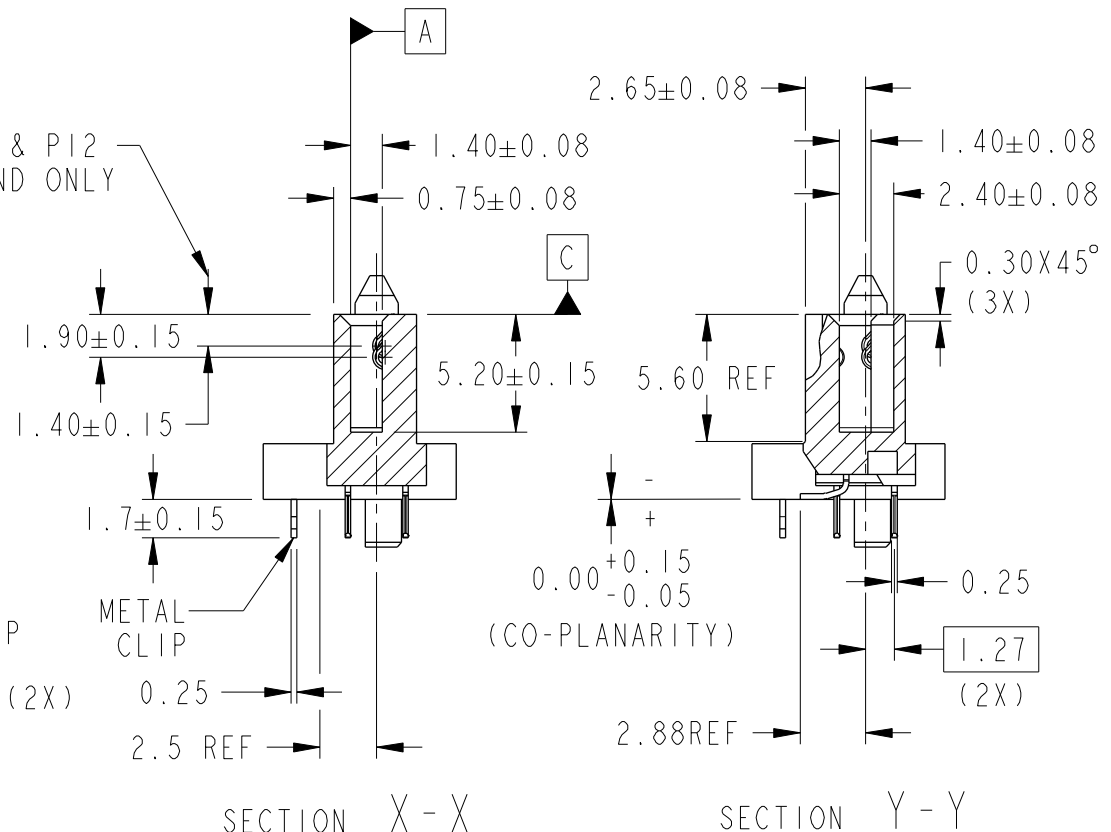
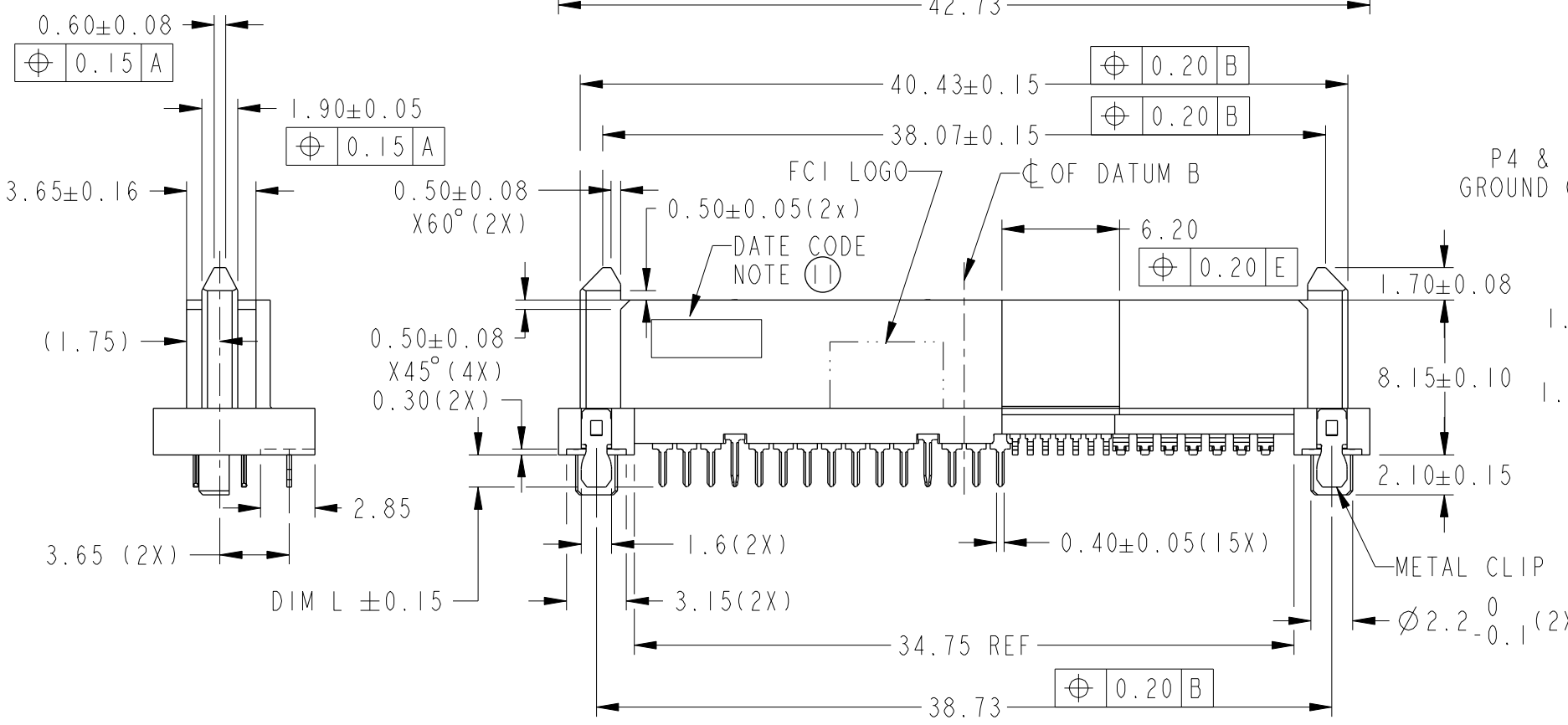
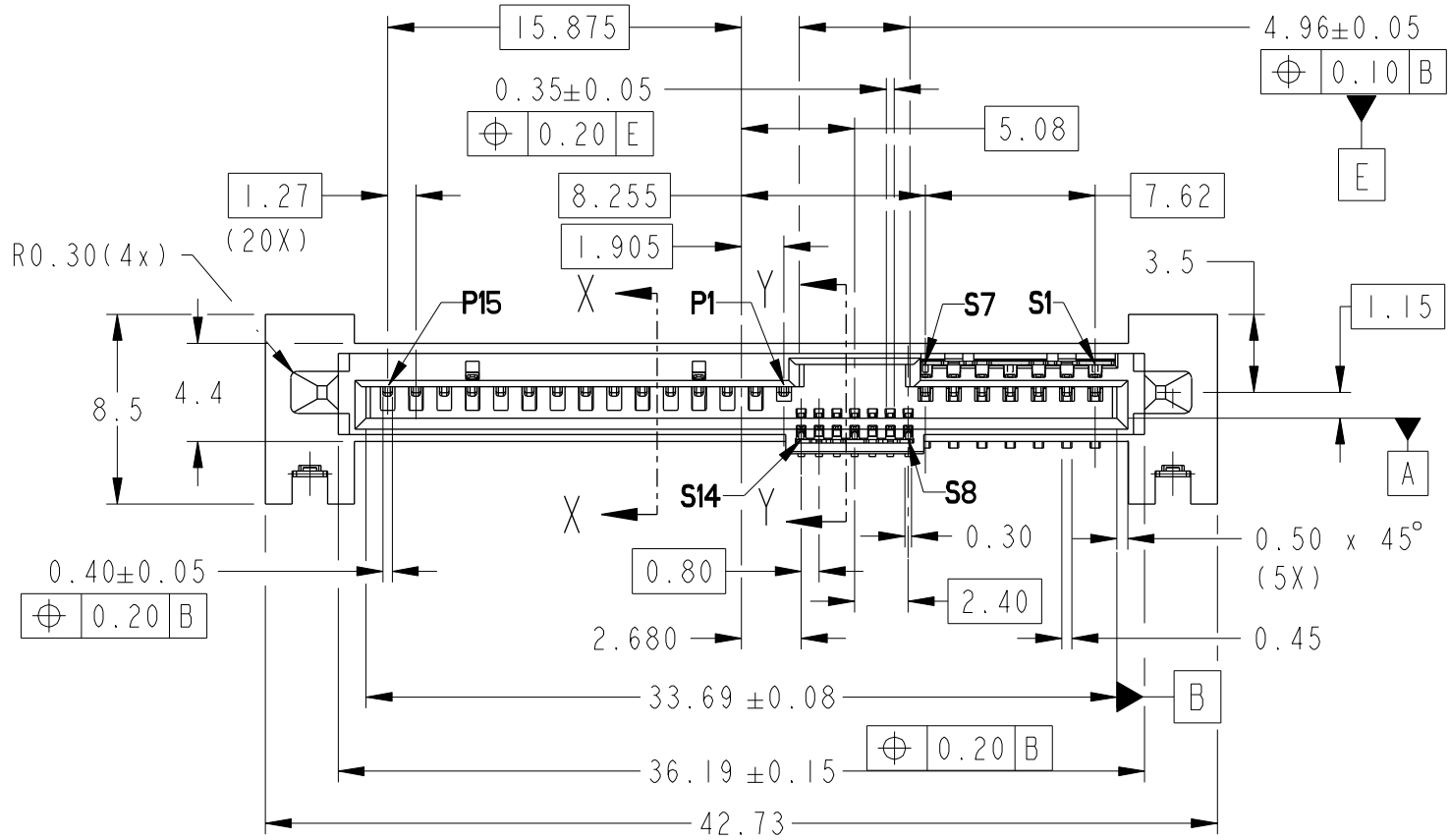

Amphenol FCI
© 2016 AFCI

spec ref	-	dr	M Srinivasan	2013/06/19	projection	MM	size	A3	scale	3:1	
tolerance std	ISO 1101	eng	Noorhazlinda	2017/04/10			ecn no	ELX-M-26592-1			
TOLERANCES UNLESS OTHERWISE SPECIFIED		chr	-	-			rel level	Released			
surface	linear	appr	Koon-Poh Tay	2017/05/17	product family	SAS	rel level	Released			
ISO 1302	angular	0°	±2°	Amphenol FCI	part no	12G SAS RECEPTACLE	dwg no	10120863		rev	E
					cat. no.	-	Product - Customer Drw	sheet 1 of 4			

PRODUCT NO	DIM L	PICK-UP CAP	RECOMMENDED P.C. BOARD THICKNESS	TYPE OF CLIP	PACKAGING
	(SOLDER TAIL)				
10120863-001LF	1.70	NO	1.57mm (0.062") / 2.36mm (0.093") / 3.43mm (0.135")	METAL BLADE A E	TRAY
10120863-001CLF		YES			TAPE & REEL
10120863-001C-TRLF		YES			
10120863-002LF	2.10	NO	2.36mm (0.093") / 3.43mm (0.135")	METAL BLADE A E	TRAY
10120863-002CLF		YES			TAPE & REEL
10120863-002C-TRLF		YES			

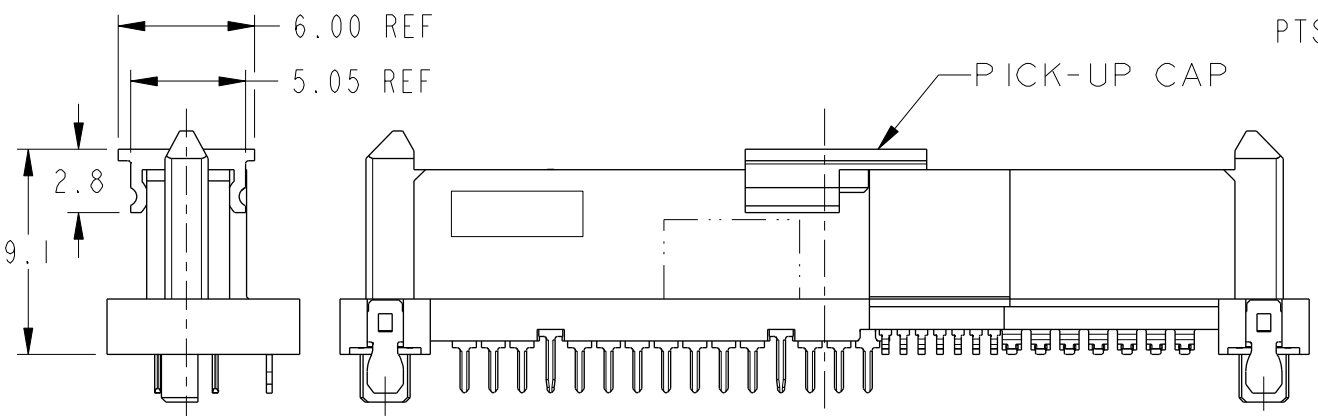
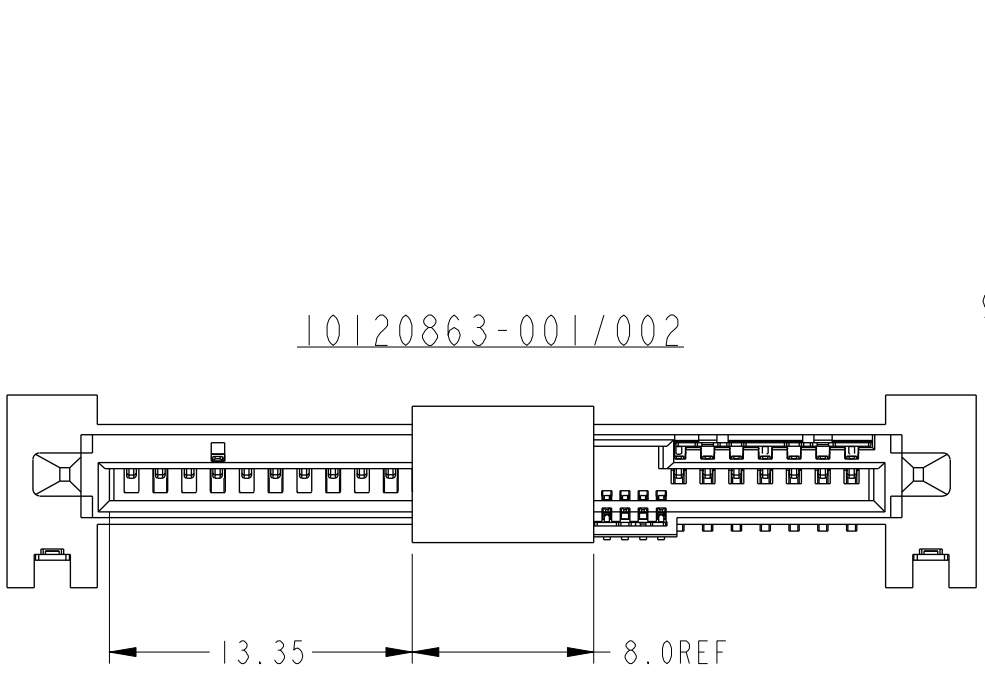

PART WITH PICK-UP CAP, SEE NOTE ④

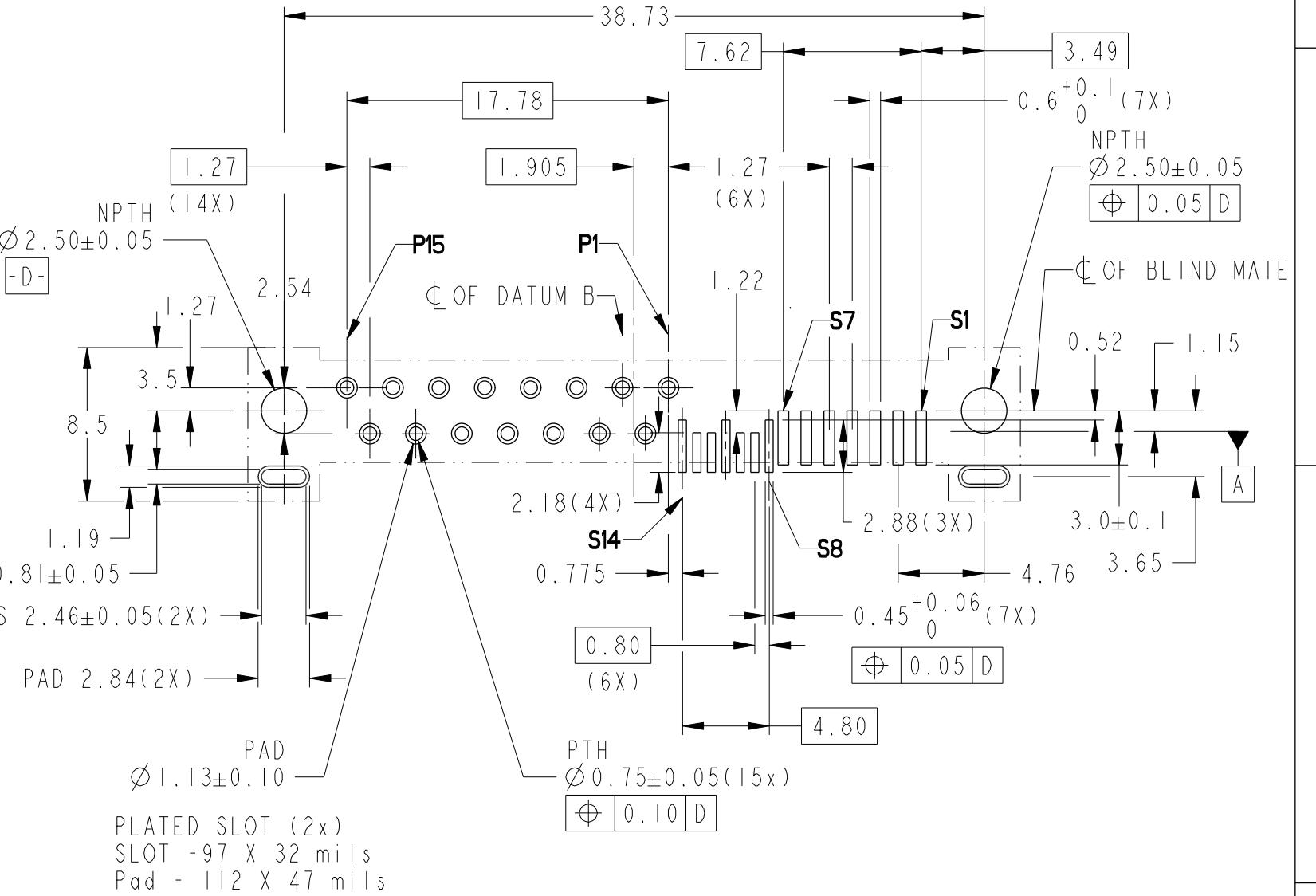

RECOMMENDED PCB LAYOUT

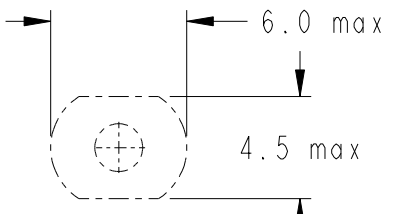

RECOMMENDED SUCTION HEAD SIZE

spec ref	-		
tolerance std	TOLERANCES UNLESS OTHERWISE SPECIFIED		
ISO 1101	linear	0.X	±
		0.XX	±.20
		0.XXX	±
ISO 1302	angular	0°	±2°

dr	M Srinivasan	2013/06/19	projection	MM	size	A3	scale	3:1
eng	Noorhazelinda	2017/04/10	product family	SAS	ecn no	ELX-M-26592-1	rel level	Released
chr	-	-						
appr	Koon-Poh Tay	2017/05/17	Product - Customer Drw		sheet 2 of 4			
Amphenol FCI				12G SAS RECEPTACLE		10120863		rev
				WIDE BASE HYBRID TYPE ASSY				E
cat. no.				-				

© 2016 AFCI Amphenol FCI

PRODUCT NO	DIM L	PICK-UP CAP	RECOMMENDED P.C. BOARD THICKNESS	TYPE OF CLIP	PACKAGING
	(SOLDER TAIL)				
10120863-003LF	2.10	NO	2.36mm (0.093") / 3.43mm (0.135")	METAL BLADE A $\triangle E$	TRAY
10120863-003CLF		YES			TAPE & REEL
10120863-003C-TRLF		YES			
10120863-004LF	1.70	NO	1.57mm (0.062") / 2.36mm (0.093") / 3.43mm (0.135")	METAL BLADE B	TRAY
10120863-004CLF		YES			TAPE & REEL
10120863-004C-TRLF		YES			

10120863-003
(WITH CLOSURE ON HOLD DOWN AREA)

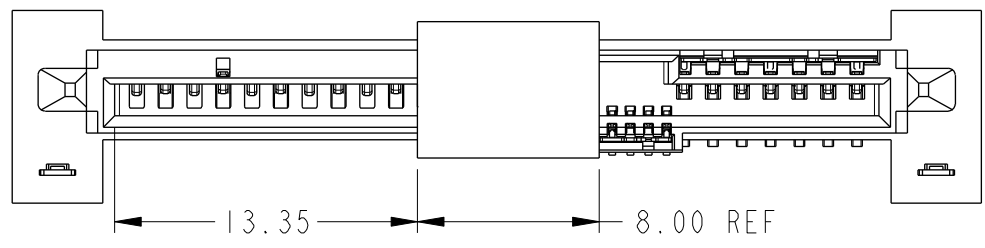

10120863-004
(WITH CLOSURE ON HOLD DOWN AREA) $\triangle E$

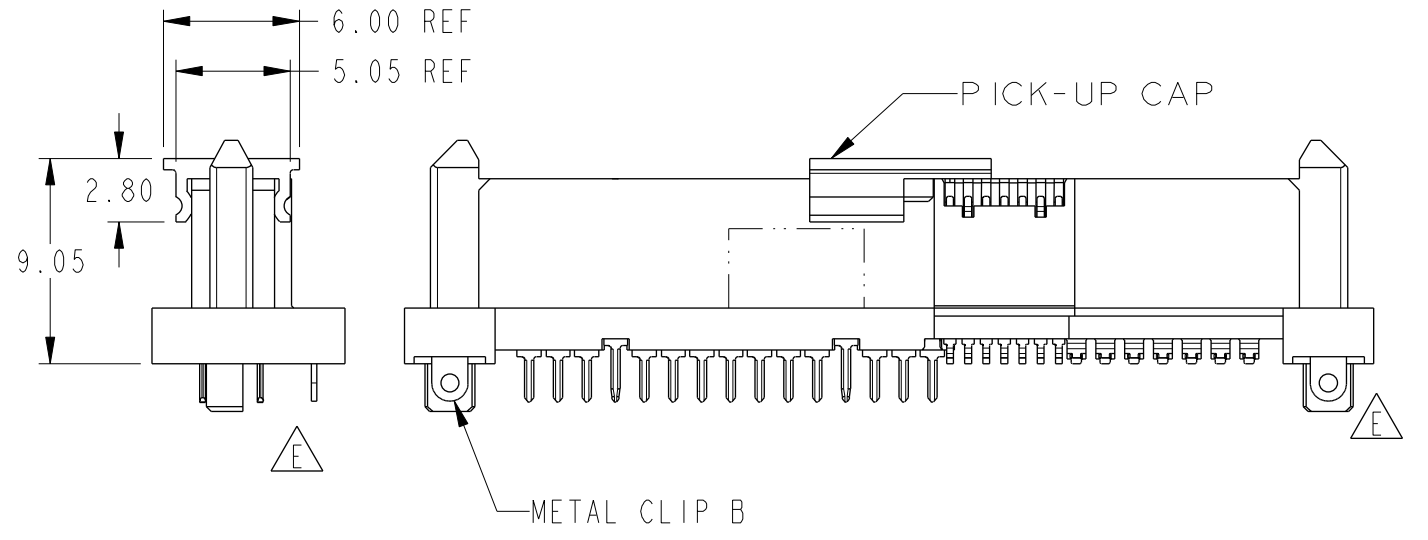
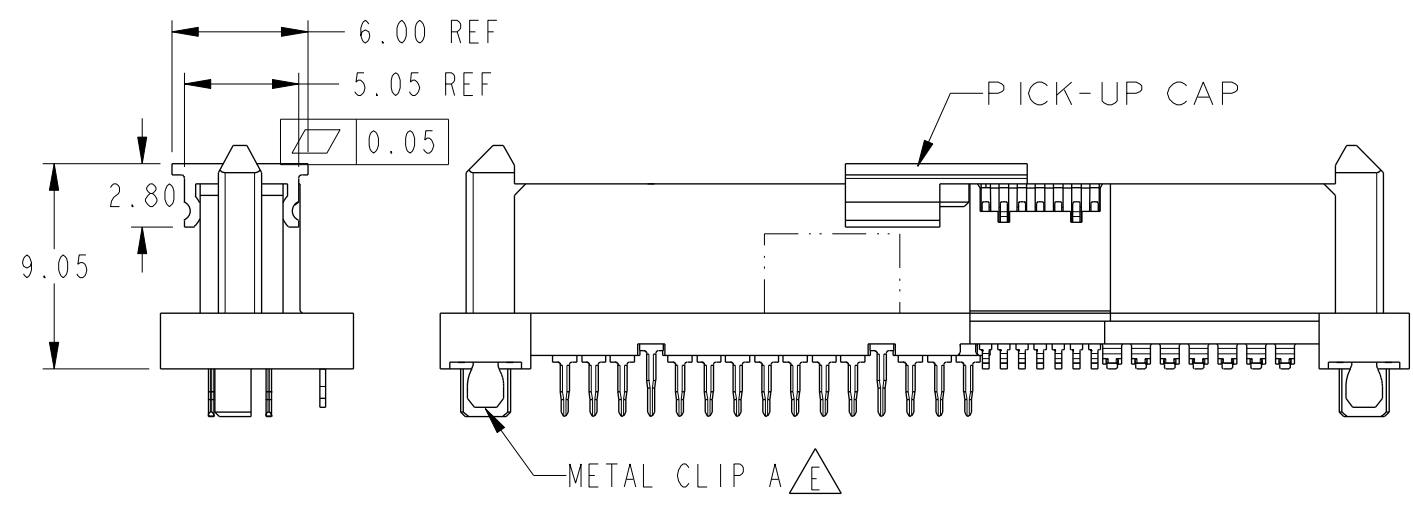
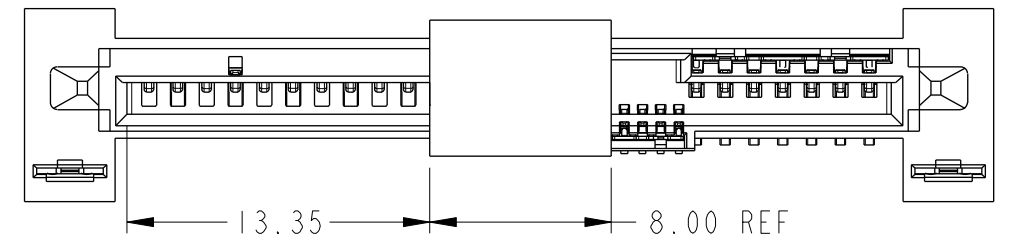

PART WITH PICK-UP CAP, SEE NOTE ④

spec ref	-	dr	M Srinivasan	2013/06/19	projection	MM	size	A3	scale	1:1	
tolerance std	ISO 1101	eng	Noorhazlinda	2017/04/10			ecn no	ELX-M-26592-1			
TOLERANCES UNLESS OTHERWISE SPECIFIED		chr	-	-			product family	SAS	rel level	Released	
surface	linear	appr	Koon-Poh Tay	2017/05/17			cat. no.	-	Product - Customer Drw	sheet 3 of 4	
	angular				12G SAS RECEPTACLE WIDE BASE HYBRID TYPE ASSY		dwg no	10120863		rev	E

PRODUCT NO
SEE TABLE

NOTES:

- 1 MATERIAL:
 - 1)HOUSING: HIGH TEMP TERMOPLASTIC, UL 94V-0
COLOR: BLACK
 - 2)TERMINAL: COPPER ALLOY
 - 3)HOLD DOWN: COPPER ALLOY
- 2 FINISH
 - 1)TERMINAL: 30μ" Au PLATING (CONTACT POINT) OVER
50μ" NICKEL
 - 2)SOLDER TAIL: 75μ" min Sn OVER 50μ" NICKEL
 - 3)HOLD DOWN: 75μ" min Sn OVER 50μ" NICKEL
- 3 PER SFF REV 1.3 EXCEPT 0.8mm PITCH BUMP AREA
- 4 PART WITH PICK-UP CAP, P/N XXXXXXXX-XXXC LF
- 5 THE STD PACKAGING IS IN TRAY
- 6 FOR TAPE & REEL PACKAGING, SUFFIX "-TR" ADDED AFTER
PRODUCT NUMBER (E.G. XXXXXXXX-XXXC-TRLF)
- 7 THE HOUSING WILL WITHSTAND EXPOSURE TO 260°C PEAK
TEMPERATURE FOR 10 SECONDS IN A CONVECTION, INFRA-RED
OR VAPOUR PHASE REFLOW OVEN.
- 8 THIS PRODUCT MEETS EUROPEAN UNION DIRECTIVES AND
OTHER COUNTRY REGULATIONS AS DESCRIBED IN GS-47-0004
- 9 PART NUMBERS ENDING IN "LF" MEANS FOR NOTE 8 LEAD FREE
IDENTIFICATION
- 10 A Δ SYMBOL WILL BE NEXT TO ANY DIMENSION, VIEW OR NOTE
WHICH HAS BEEN MODIFIED WITH THE CURRENT DRAWING REVISION
- 11 DATE CODE LOCATION. DATE CODE NO. YYWWD (E.G. 14225)
- 12 CORING AT NON FUNCTIONAL AREAS ARE SUBJECT TO CHANGE
WITHOUT NOTICES.

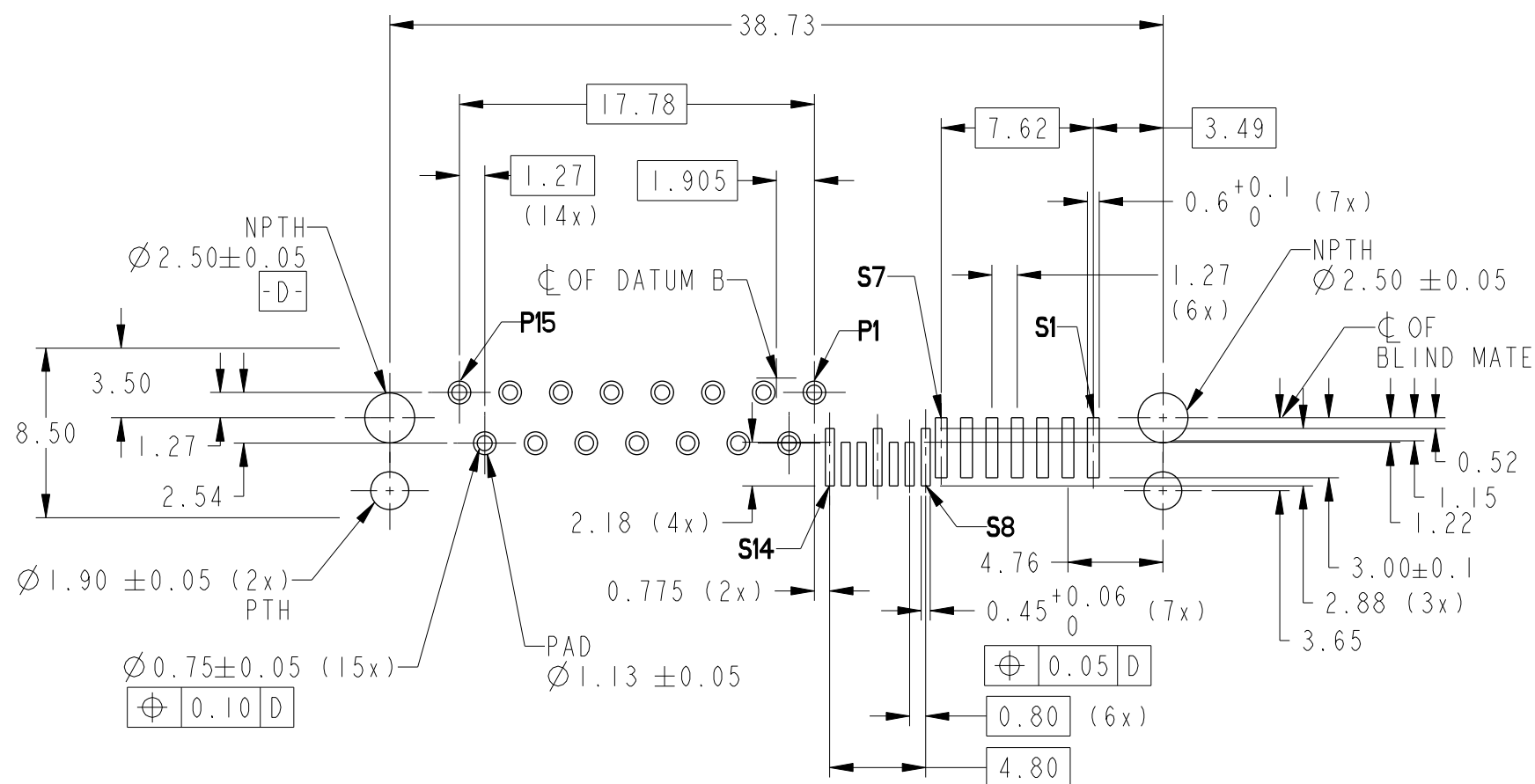

PLATED HOLES (15X)
FHS - 29.5 mils
Pad - 44.5 mils

RECOMMENDED PCB LAYOUT
(WITH ROUND SHAPE PTH FOR CLIP)

spec ref	-	dr	M Srinivasan	2013/06/19	projection	MM	size	A3	scale	1:1
tolerance std	ISO 1101	eng	Noorhazlinda	2017/04/10			ecn no	ELX-M-26592-1	rel level	Released
TOLERANCES UNLESS OTHERWISE SPECIFIED		chr	-	apppr						
surface	linear	0.X	± -		12G SAS RECEPTACLE		dwg no	10120863	rev	E
		0.XX	±.20		WIDE BASE HYBRID TYPE ASSY					
	angular	0°	±2°		cat. no.	-				