

NOTES: UNLESS OTHERWISE SPECIFIED

1. MATERIAL:
HOUSING: THERMOPLASTIC
SEAL: SILICONE RUBBER
CONTACT: COPPER ALLOY
2. MODIFICATIONS: FLANGE; PCB MOUNT, RIGHT ANGLE
3. SPECIFICATIONS:
3.1 CURRENT RATING: 13 AMPS
3.2 OPERATING TEMPERATURE: -55°C TO +125°C
3.3 DIELECTRIC WITHSTANDING VOLTAGE: LESS THAN 2 MILLIAMPS CURRENT LEAKAGE @ 1500 VOLTS AC.
3.4 INSULATION RESISTANCE: 1000 MEGOHMS MIN @ 25°C.
3.5 MOISTURE RESISTANCE: IP67 (MATED CONDITION)
3.6 MATING CYCLE DURABILITY: 100 CYCLES
3.7 RoHS COMPLIANT
4. MATING PART: AT06-4S* PLUG
(* = MODIFICATIONS)
5. ALL DIMENSIONS ARE FOR REFERENCE USE ONLY.
6. POTTED CONNECTORS SPECIFIED FOR UP TO 5 P.S.I. APPLICATIONS.

AT13-4P-BMXX VARIANTS		
CONTACT PLATING	POTTING OR NOT IN RESERVOIR	PART NUMBER
GOLD	NO POTTING	AT13-4P-BM01
GOLD	POTTING	AT13-4P-BM02
TIN	NO POTTING	AT13-4P-BM03
TIN	POTTING	AT13-4P-BM04

REVISIONS					
REV	ECO	DESCRIPTION	DATE	BY	APPR
A1	--	RELEASE NEW DRAWING	20JUN18	JONY	TOMMY
A2	--	REVISED DRAWING	10JUL20	JHEAD	DH

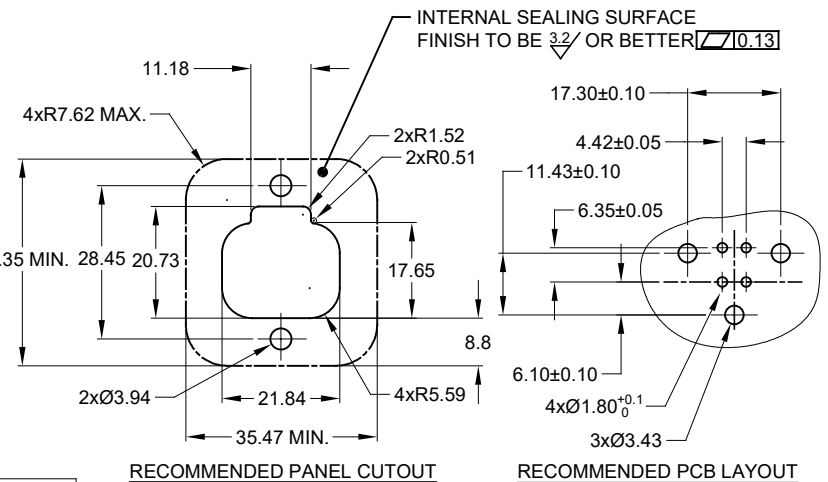
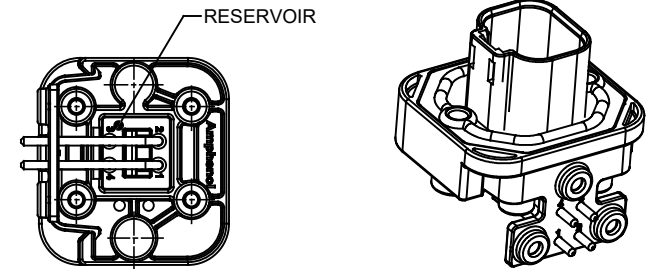

RECOMMENDED PANEL CUTOUT

RECOMMENDED PCB LAYOUT

AT13-4P-BMXX		REF: DT13-4P		DESCRIPTION		ITEM
QUANTITY	PART NUMBER	MATERIALS LIST				
UNLESS OTHERWISE SPECIFIED 1) All dimensions are in metric (mm). 2) Tolerances are as follows: 1 PL DEC ±0.30 Fractions ± 1/64 2 PL DEC ±0.15 Angles ±1° 3 PL DEC ±0.08						
SIGNATURES		DATE		 Sine Systems - www.amphenol-sine.com 44724 Morley Drive Clinton Township, MI 48036 BOARDLOCK PCB MOUNT RECEPTACLE, 4 PIN, RA FLANGE, AT SERIES		
DRAWN: JONY,XIE		20JUN18				
CHECKED: ORION,LI		20JUN18				
ENGINEER:						
APPROVAL: TOMMY,XIE		20JUN18		CUSTOMER:		
MATERIAL SPECIFICATIONS:		CUSTOMER:		THIS DRAWING IS SUPPLIED FOR INFORMATION ONLY. DESIGN FEATURES, SPECIFICATIONS AND PERFORMANCE DATA SHOWN HEREON ARE THE PROPERTY OF THE AMPHENOL CORPORATION. NO RIGHTS OF REPRODUCTION ARE IMPLIED. ALL DIMENSIONS ARE SUBJECT TO NORMAL MANUFACTURING VARIATIONS.		
PROCESS SPECIFICATIONS:		CUSTOMER:		SIZE: B	TYPE: C-	DWG NO: AT13-4P-BMXX
NEXT ASSY:		CUSTOMER:		SCALE: NONE	REVISION: A2	
						SHEET 1 OF 1

ATTORNEY: PCB MOUNT RECEPT, PIN RA FLANGE, AT SERIES DWG NO: AT13-4P-BMXX REV: A2 SH: 1 OF: 1