

SMD ■ B EASV3015ICRGBA0

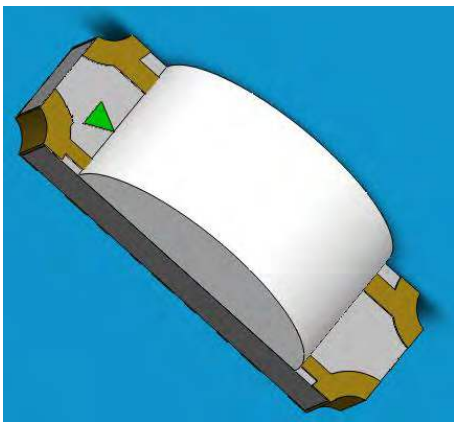

Features

- . Package in 8mm tape on 7" diameter reel.
- . Compatible with automatic placement equipment.
- . Compatible with infrared and vapor phase reflow solder process.
- . Full-color type.
- . 8 bit PWM control with 256 grayscales for each RGB chip.
- . Pb-free
- . The product itself will remain within RoHS compliant version.
- . Compliance with EU REACH.
- . Compliance Halogen Free .(Br <900 ppm ,Cl <900 ppm , Br+Cl < 1500 ppm)

Description

- . The EASV3015ICRGBA0 SMD LED is much smaller than lead frame type components, thus enable smaller board size, higher packing density, reduced storage space and finally smaller equipment to be obtained.
- . Besides, lightweight makes them ideal for miniature applications. etc.
- . The EASV3015ICRGBA0 with a 3-channels LED driver with 8 bit PWM linear control.

Applications

- . Indoor/Outdoor LED video display.
- . Full color LED light strip.
- . LED decorative lighting.
- . Backlighting in dashboard and switch.
- . Telecommunication: indicator and backlighting in telephone and fax.
- . Flat backlight for LCD, switch and symbol.
- . General use.

Device Selection Guide

Code	Chip Materials	Emitted Color	Resin Color
RS	AlGaInP	Brilliant Red	White Diffused
GH	InGaN	Brilliant Green	
BH	InGaN	Blue	

Absolute Maximum Ratings (Ta=25°C)

Parameter	Symbol	Code	Rating	Unit
Supply Voltage	V _{DD}		+3.8~+5.5	V
Output Voltage	V _{OUT}		17	V
Input Voltage	V _{IN}		-0.5~V _{DD} +0.5	V
Electrostatic Discharge(HBM)	ESD		2000	V
Operating Temperature	T _{opr}		-20 ~ +70	°C
Storage Temperature	T _{stg}		-40 ~ +90	°C
Soldering Temperature	T _{sol}		Reflow Soldering : 260 °C for 10 sec. Hand Soldering : 350 °C for 3 sec.	

Recommended Operating Condition (Ta=-20~70°C , V_{SS}=0V)

Parameter	Symbol	Condition	Min	Typ.	Max.	Unit
Supply Voltage	V _{DD}	-----	-----	5.0	-----	V
Input Voltage(High)	V _{iH}	-----	0.7V _{DD}	-----	V _{DD}	0V
Input Voltage(Low)	V _{iL}	-----	0	-----	0.3V _{DD}	V

Recommended Operating Condition (Ta=-20~70°C , Vss=0V)

Parameter	Symbol	Condition	Min	Typ.	Max.	Unit
Propagation Delay Time	T _{PLZ}	DIN→DOUT CL=15pF, RL=10KΩ	-----	-----	300	ns
Falling Time	T _{THZ}	CL=300pF OUTR/OUTG/OUTB	-----	-----	20	μs
Input Capacitor	C _i		-----	-----	15	pF

Timing Wave Form

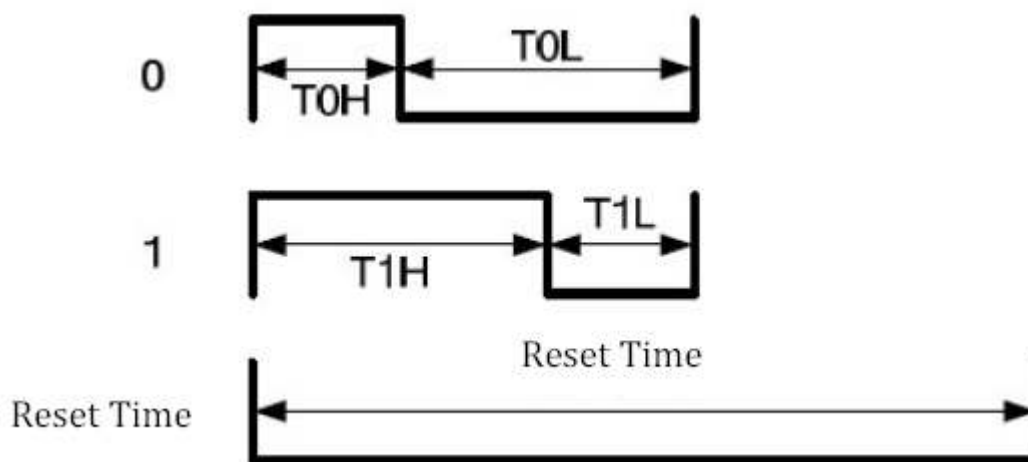

High Speed mode

Item	Description	Typical	Allowance
T _{0H}	0 code • High-level time	300ns	±80ns
T _{0L}	0 code • Low-level time	900ns	±80ns
T _{1H}	1 code • High-level time	900ns	±80ns
T _{1L}	1 code • Low-level time	300ns	±80ns
RES	Reset time	>50us	

Data Communication

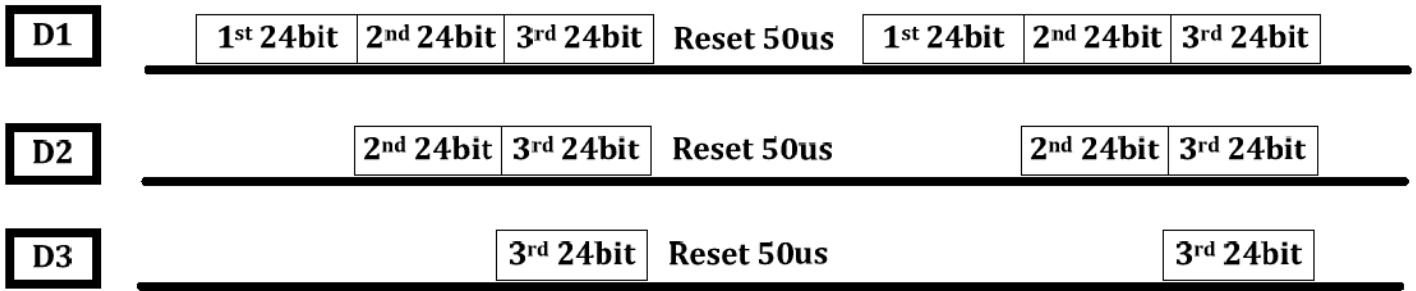

Single Data in 24bit for RGB

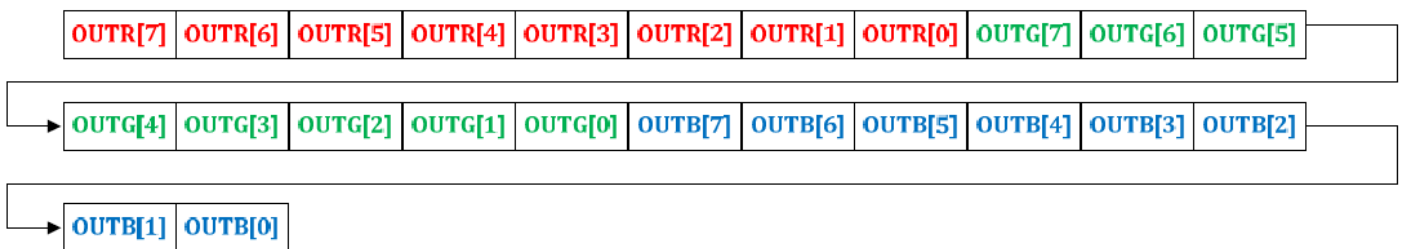

5V Application circuit

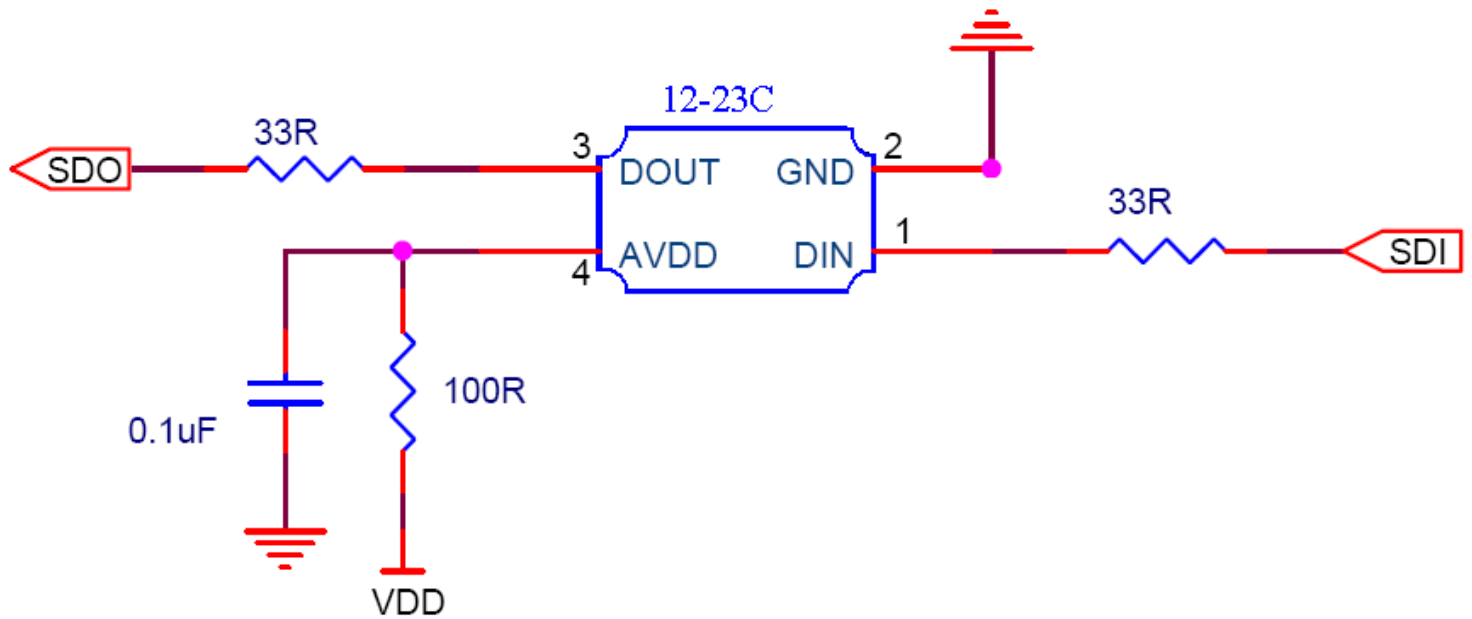

When EASV3015ICRGBA0 is set to operate on 5V power system, a 0.1uF capacitor is recommended to add between power supply and ground terminal. The capacitor is suggested to put as closer as possible to IC position. There are frequent resistors were used on different drain voltage as listed table.

Electro-Optical Characteristics (Ta=25°C)

Parameter	Symbol	Code	Min.	Typ.	Max.	Unit	Condition
Luminous Intensity	I _v	RS	22.5	-----	72.0	mcd	
		GH	45.0	-----	140.0		
		BH	18.0	-----	57.0		
Viewing Angle	2θ _{1/2}		-----	130	-----	Deg	
Peak Wavelength	λ _p	RS	-----	632	-----	nm	I _F =5mA
		GH	-----	518	-----		
		BH	-----	468	-----		
Dominant Wavelength	λ _d	RS	617.5	-----	629.5	nm	
		GH	525.0	-----	540.0		
		BH	464.5	-----	476.5		
Spectrum Radiation Bandwidth	Δλ	RS	-----	20	-----	nm	
		GH	-----	35	-----		
		BH	-----	25	-----		

Note:

1. Tolerance of Luminous Intensity: ±11%
2. Tolerance of Dominant Wavelength: ±1nm

**Bin Range of Luminous Intensity
RS**

Bin Code	Min.	Max.	Unit	Condition
M2	22.5	28.5	mcd	I _F =5mA
N1	28.5	36.0		
N2	36.0	45.0		
P1	45.0	57.0		
P2	57.0	72.0		

GH

Bin Code	Min.	Max.	Unit	Condition
P1	45.0	57.0	mcd	I _F =5mA
P2	57.0	72.0		
Q1	72.0	90.0		
Q2	90.0	112.0		
R1	112.0	140.0		

BH

Bin Code	Min.	Max.	Unit	Condition
M1	18.0	22.5	mcd	I _F =5mA
M2	22.5	28.5		
N1	28.5	36.0		
N2	36.0	45.0		
P1	45.0	57.0		

Note:
Tolerance of Luminous Intensity: ±11%

**Bin Range Of Dom. Wavelength
RS**

Bin Code	Min.	Max.	Unit	Condition
E4	617.5	621.5	nm	I _F =5mA
E5	621.5	625.5		
E6	625.5	629.5		

GH

Bin Code	Min.	Max.	Unit	Condition
Y	525.0	530.0	nm	I _F =5mA
Z	530.0	535.0		
V	535.0	540.0		

BH

Bin Code	Min.	Max.	Unit	Condition
A9	464.5	467.5	nm	I _F =5mA
A10	467.5	470.5		
A11	470.5	473.5		
A12	473.5	476.5		

Note:
Tolerance of Dominant Wavelength ±1nm

Package Dimension

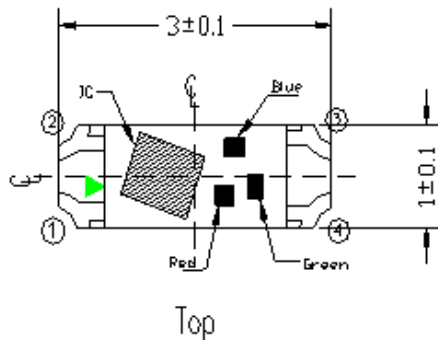

- ① DIN
- ② GND
- ③ DOUT
- ④ AVDD

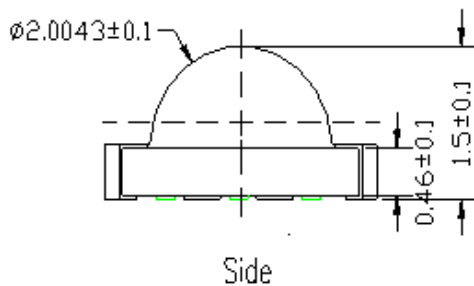

Recommend Sodering Pad

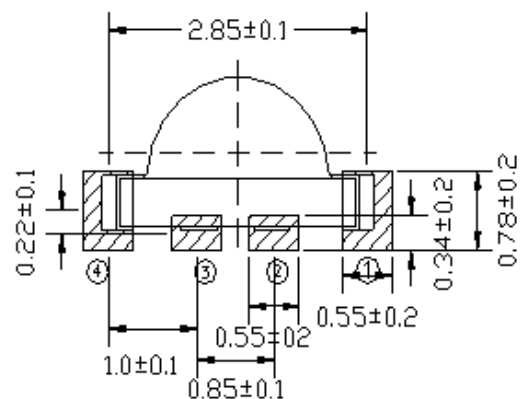
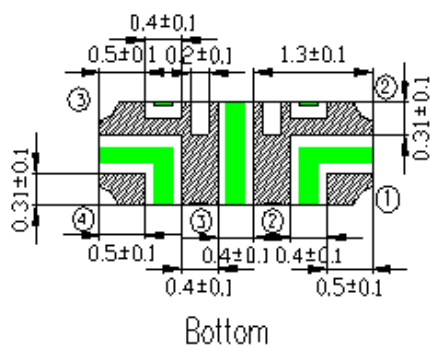

Suggested pad dimension is just for reference only.
Please modify the pad dimension based on individual need.

Note: Tolerances unless mentioned ± 0.1 mm. Unit = mm

PIN Function

NO.	Symbol	PIN	Function description
1	DIN	DATA IN	Control data signal input
2	GND	GROUND	Data & Power Grounding
3	DOUT	DATA OUT	Control data signal output
4	AVDD	POWER VOLTAGE	Power Voltage, connect to "+5V"

**Moisture Resistant Packing Materials
Label Explanation**

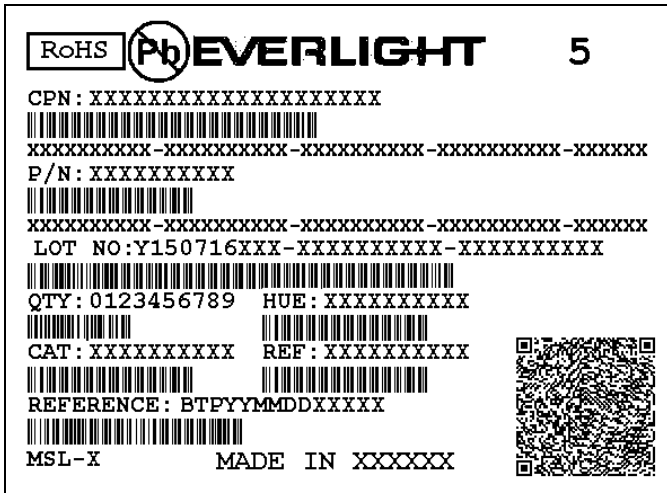

- CPN: Customer's Product Number
- P/N: Product Number
- QTY: Packing Quantity
- CAT: Luminous Intensity Rank
- HUE: Chromaticity Coordinates & Dom. Wavelength Rank
- REF: Forward Voltage Rank
- LOT No: Lot Number

Reel Dimensions

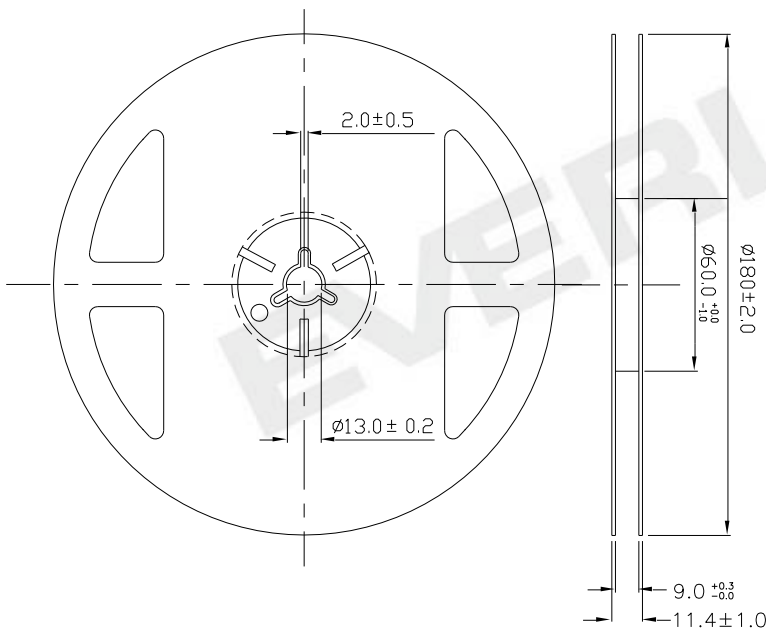

Note: The tolerances unless mentioned is $\pm 0.1\text{mm}$,Unit = mm

Carrier Tape Dimensions: Loaded quantity 2000 PCS per reel

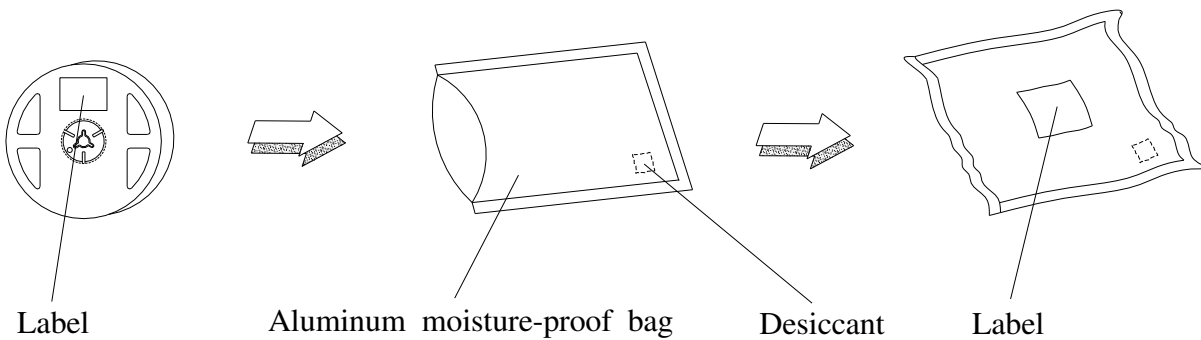
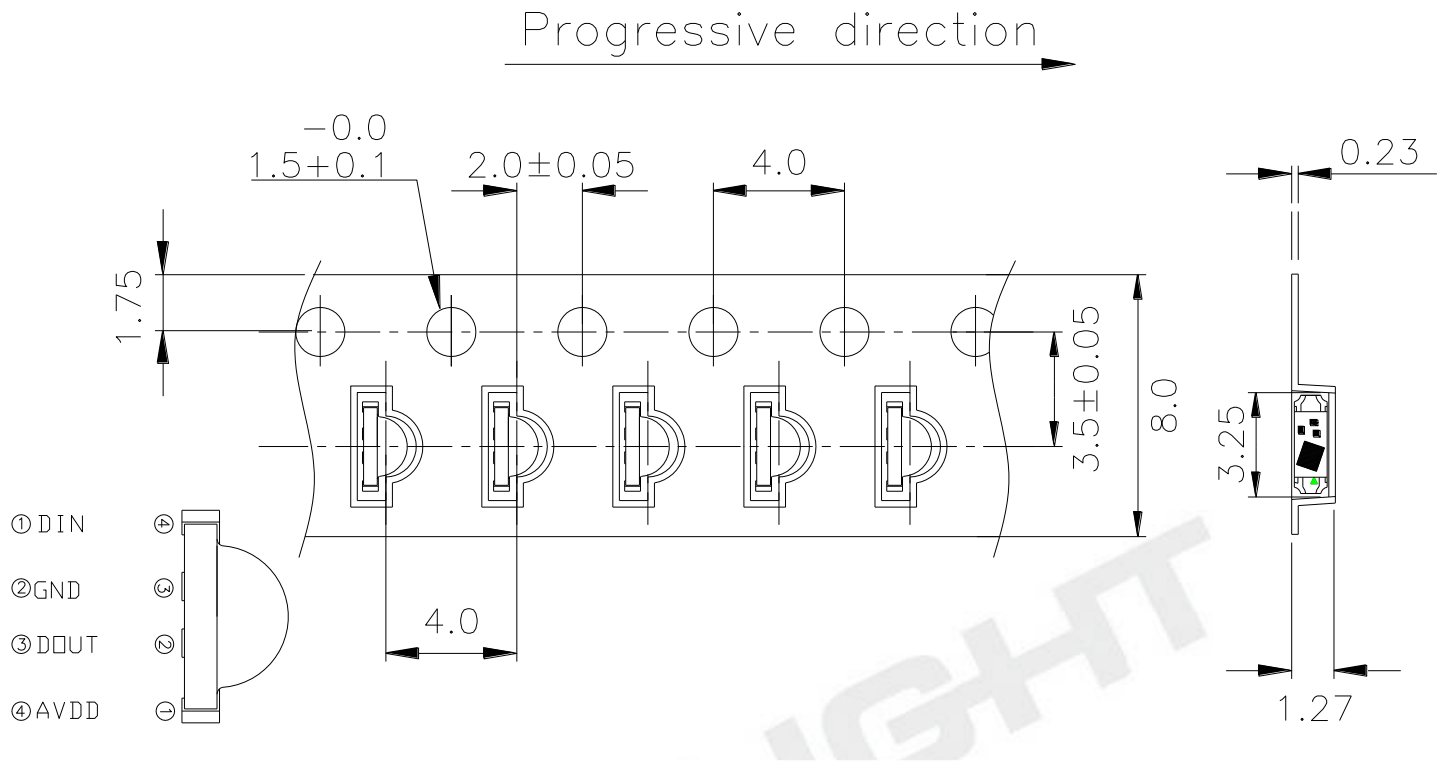

Precautions For Use

1. Over-current-proof

Customer must apply resistors for protection, otherwise slight voltage shift will cause big current change (Burn out will happen).

2. Storage

2.1 Do not open moisture proof bag before the products are ready to use.

2.2 Before opening the package: The LEDs should be kept at 30°C or less and 90%RH or less.

2.3 After opening the package: The LEDs floor life is 24hrs under 30°C or less and 60% RH or less..

If unused LEDs remain, it should be stored in moisture proof packages

2.4 If the moisture absorbent material (silica gel) has faded away or the LEDs have exceeded the storage time, baking treatment should be performed using the following conditions.

Baking treatment : 60±5°C for 24 hours

3. Soldering Condition

3.1 Pb-free solder ter

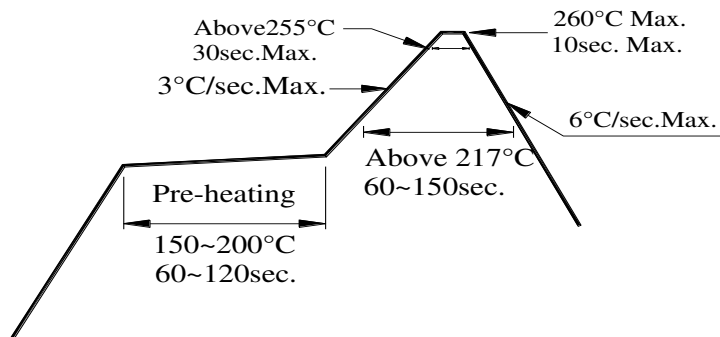

3.2 Reflow soldering should not be done more than two times.

3.3 When soldering, do not put stress on the LEDs during heating.

3.4 After soldering, do not warp the circuit board.

4. Soldering Iron

Each terminal is to go to the tip of soldering iron temperature less than 350°C for 3 seconds within once in less than the soldering iron capacity 25W. Leave two seconds and more intervals, and do soldering of each terminal. Be careful because the damage of the product is often started at the time of the hand solder.

5. Repairing

Repair should not be done after the LEDs have been soldered. When repairing is unavoidable, a double-head soldering iron should be used (as below figure). It should be confirmed beforehand whether the characteristics of the LEDs will or will not be damaged by repairing.

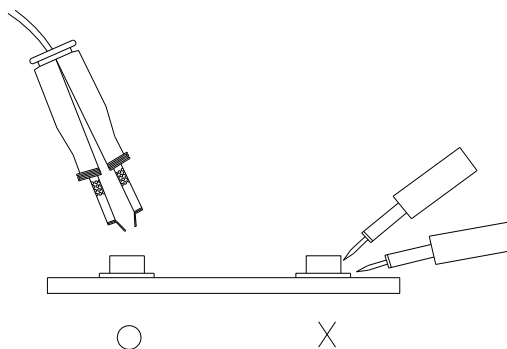

Application Restrictions

High reliability applications such as military/aerospace, automotive safety/security systems, and medical equipment may require different product. If you have any concerns, please contact Everlight before using this product in your application. This specification guarantees the quality and performance of the product as an individual component. Do not use this product beyond the specification described in this document.

EVERLIGHT

DISCLAIMER

1. EVERLIGHT reserves the right(s) on the adjustment of product material mix for the specification.
2. The product meets EVERLIGHT published specification for a period of twelve (12) months from date of shipment.
3. The graphs shown in this datasheet are representing typical data only and do not show guaranteed values.
4. When using this product, please observe the absolute maximum ratings and the instructions for using outlined in these specification sheets. EVERLIGHT assumes no responsibility for any damage resulting from the use of the product which does not comply with the absolute maximum ratings and the instructions included in these specification sheets.
5. These specification sheets include materials protected under copyright of EVERLIGHT. Reproduction in any form is prohibited without obtaining EVERLIGHT's prior consent.
6. This product is not intended to be used for military, aircraft, automotive, medical, life sustaining or life saving applications or any other application which can result in human injury or death. Please contact authorized Everlight sales agent for special application request.

EVERLIGHT