

Modular Plug Connectors Compliant to Enhanced Category 5 Standards

TM21P Series (Shielded Type)

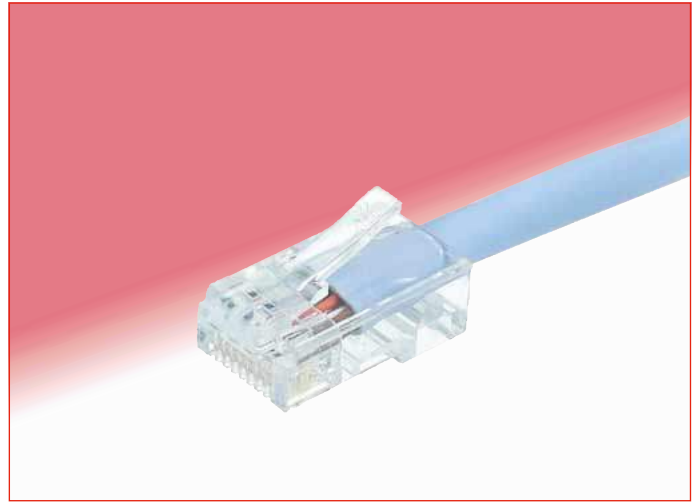

TM22P-88P (Non-shielded Type)



■ Features

1. Supports High-Speed LAN Transmission

Conforms to requirements of TIA/EIA-568B data wiring standard, meeting transmission performance of Enhanced Category 5. Supports Gigabit Ethernet (1000BASE-T) and Fast Ethernet (100BASE-TX) high-speed LAN transmission.

2. EMI protection (TM21*P-88P)

360° coverage of the engagement area with a metal shield assures protection against electromagnetic interference. When mated with corresponding connector the shield surfaces are securely connected to provide continuous circuit.

3. Protected latch tab (TM21P-88P)

Flexible case extends over the release tab preventing the possibility of breaking-off during handling of the complete cable assembly.

4. Termination of conductors

Self located 24 AWG conductors (solid or stranded) are terminated against pre-inserted contacts using simple tooling.

5. Simplified termination (TM21*P-88P)

Removeable one piece cover allows easy access to the termination areas.

6. Conforms to the ISO 8877 Standard (ISDN Interface Connector)

■ Applications

Telecom Hubs, Routers, Bridges and ATM Transmission Equipment, Ethernet Switches and Networking Equipment, Test and Measurement Equipment and other equipment requiring this type of simple and reliable connection.

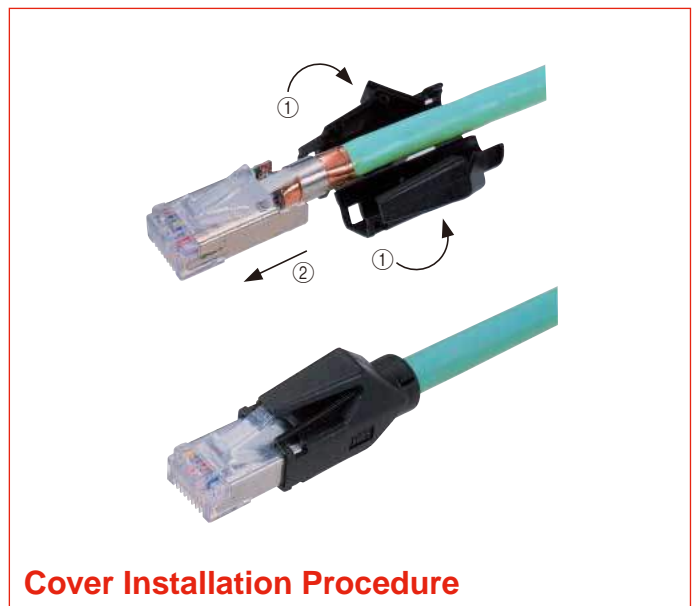

Cover Installation Procedure

Product Specification

Rating	Current rating 1A	Operating temperature range -25°C to +60°C (Note)
	Voltage rating 125 V AC	

Item	Specification	Conditions
1. Insulation resistance	100 M ohms min.	100 V DC
2. Withstanding voltage (between adjacent contacts)	No flashover or insulation breakdown	500 V AC / one minute
3. Withstanding voltage (between contact and shield)	No flashover or insulation breakdown	1500 V AC / one minute
4. Contact resistance	230 m ohms max.	100mA DC
5. Vibration	No electrical discontinuity of 5 ms or more Contact resistance: 250m ohms max.	Frequency: 10 to 55 Hz, single amplitude of 0.75 mm, 2 hours / 3 axis
6. Shock	No electrical discontinuity of 5 ms. min. Contact resistance: 250m ohms max.	Acceleration of 490 m/s ² , 11 ms duration, sine half-wave waveform, 3 cycles in each of the 3 axis
7. Durability (mating/un-mating)	Contact resistance: 250m ohms max.	200
8. Temperature cycle	Contact resistance: 250 m ohms max. Insulation resistance: 100 M ohms min.	Temperature: -55°C → +5°C to +35°C → +85°C → +5°C to +35°C Duration: 30 → 5 → 30 → 5 (Minutes) 5 cycles
9. Humidity	Contact resistance: 250 m ohms max. Insulation resistance: 1 M ohms min. (High humidity) Insulation resistance: 10 M ohms min. (Dry state)	500 hours at temperature of 40°C and humidity of 90% to 95%
10. Salt Spray	Contact resistance: 250 m ohms max.	Exposed to density 5% salt water for 48 hours

Note :Includes temperature rise caused by current flow.

Materials

Part	Material	Finish	Remarks
Insulator	Polycarbonate	Color: Clear	UL94V-2
Contacts	Copper alloy	Contact area: Gold plating	—
Shield	Copper alloy	Tin plating	—
Conductor holding tray	Polycarbonate	Color: Clear	UL94V-2
Cover	Polyamide	Color: Light beige (Note)	UL94V-2

Note :Cover available in various colors. Refer to page 3.

Ordering information

●Plugs- Shielded

TM21 C P - 8 8P

① ② ① ③ ④

① Series name	TM21P: Shielded
② Cover Type	Blank: Protective latch cover C: Short cover
③ Size	8: For 8 contacts
④ Inserted contacts	8P: 8

●Plugs - Non-shielded

TM22P - 8 8P

① ② ③

① Series name	TM22P : Non-shielded
② Size	8 : For 8 contacts
③ Inserted contacts	8P: 8

■ Plug Connectors

● Shielded

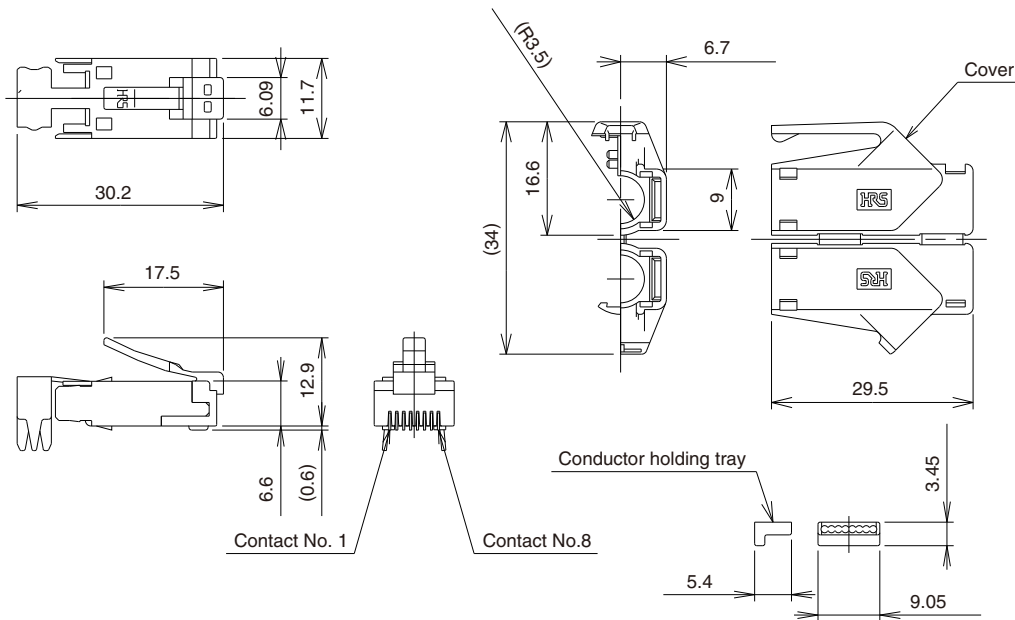
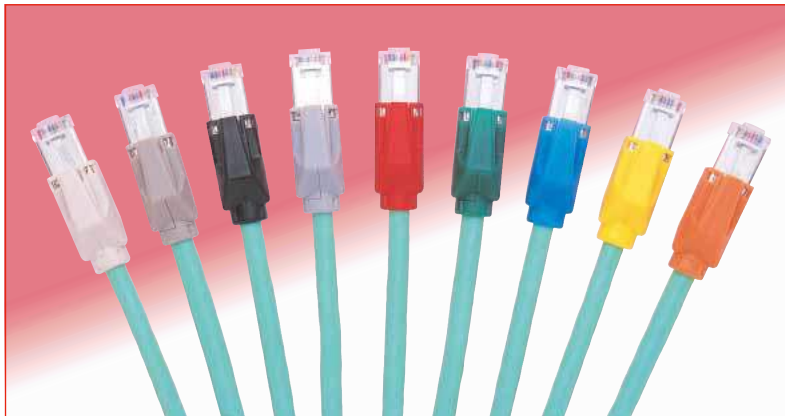
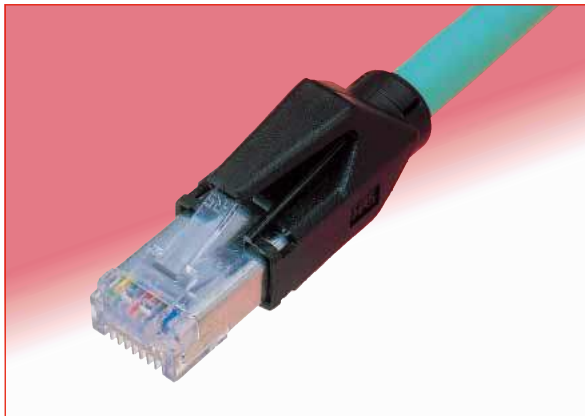

Part Number	CL No.	Cover Color	RoHS
TM21P-88P	222-2862-9	Light beige	YES
TM21P-88P(02)	222-2862-9-02	Medium gray	
TM21P-88P(03)	222-2862-9-03	Black	
TM21P-88P(04)	222-2862-9-04	Natural light gray	
TM21P-88P(05)	222-2862-9-05	Red	
TM21P-88P(06)	222-2862-9-06	Green	
TM21P-88P(07)	222-2862-9-07	Blue	
TM21P-88P(08)	222-2862-9-08	Yellow	
TM21P-88P(09)	222-2862-9-09	Orange	

◆ Cover installed

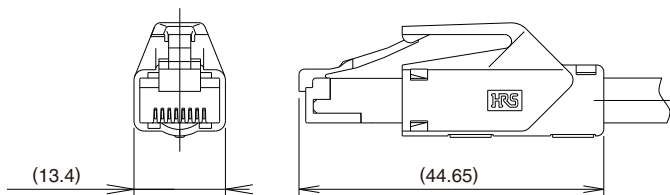

◆ Mated with corresponding receptacle (shown for reference only)

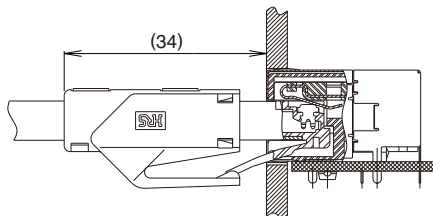

■ Plug Connectors

● Shielded-Short Cover

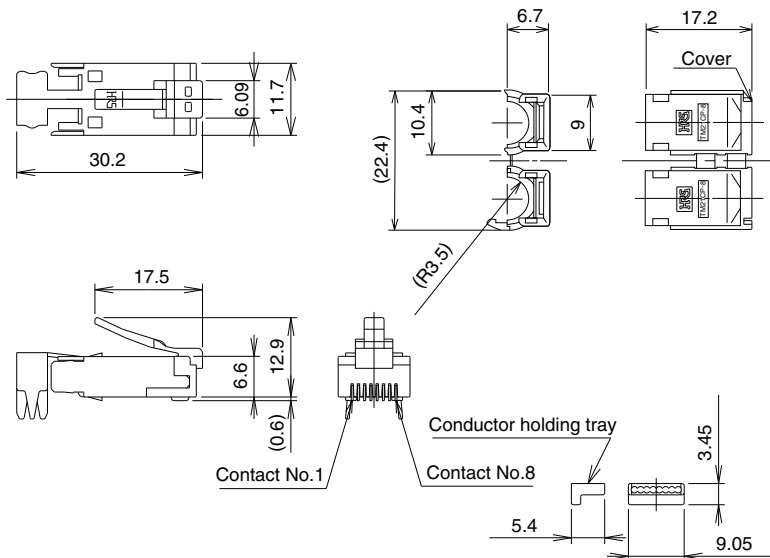

Part Number	CL No.	Cover color	RoHS
TM21CP-88P(03)	222-2884-1-03	Black	YES

Note: For other colors contact Hirose sales representative.

◆ Cover installed

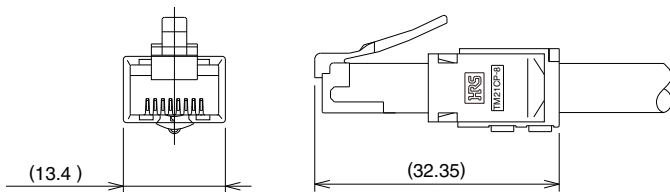

◆ Mated with corresponding receptacle (shown for reference only)

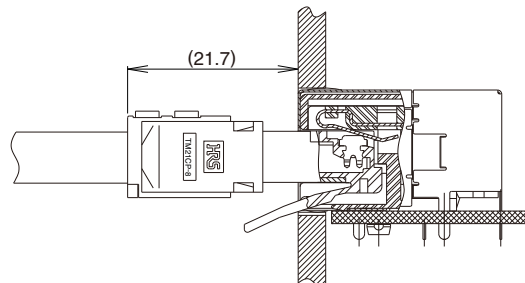

◆ Applicable Shielded Cable Specifications

Specifications		
	Conductor	Solid copper conductor: 0.5mm dia. Stranded copper conductor: AWG#24 (Dia. 0.2mm x 7 pcs)
	Individual conductor insulation dia.	(0.9mm to 1.0mm)
	Drain wire	AWG#26 (tin coated)
	Overall jacket dia.	(dia. 6.6mm)

Note: For cable termination procedures refer to:

[TM21P-88P Cable Termination Procedure Manual] (ETA-E2349) and [TM21CP-88P Cable termination Procedure Manual] (ETA-E2353).

Some cables may not meet the required service ratings. Contact Hirose sales representative for specific cable applications recommendations.

■ Plug Connectors

● Non-shielded

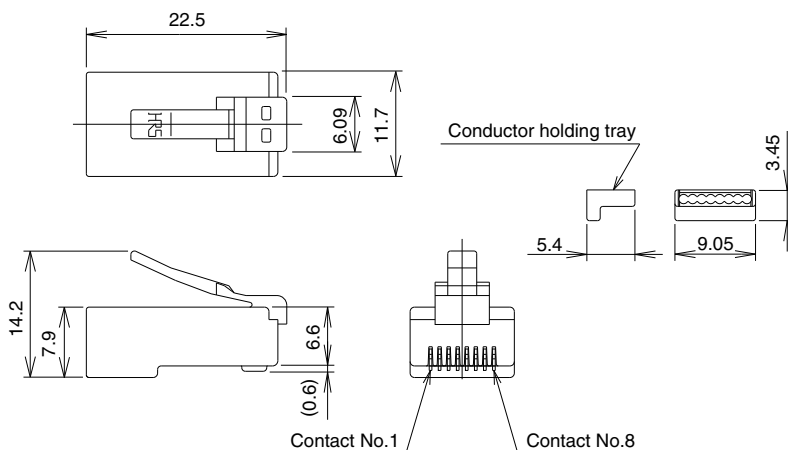

Part Number	CL No.	RoHS
TM22P-88P	222-2899-9	YES

◆ Mated with corresponding receptacle (shown for reference only)

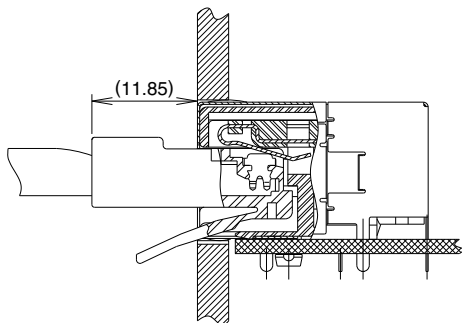

◆ Applicable Non-shielded Cable Specifications

Specifications		
	Conductor	Solid copper conductor: 0.5mm dia.
		Stranded copper conductor: AWG#24 (Dia. 0.2mm x 7 pcs)
	Individual conductor insulation dia.	(0.9mm to 1.0mm)
	Overall jacket dia.	(dia. 5.4mm to 5.7mm)

Note: For cable termination procedures refer to:

[TM22P-88P Cable Termination Procedure Manual] (ETA-E2381).

Some cables may not meet the required service ratings. Contact Hirose sales representative for specific cable applications recommendations.

◆ Hand termination tools

● For contact/conductor termination (For cable and shield crimping)

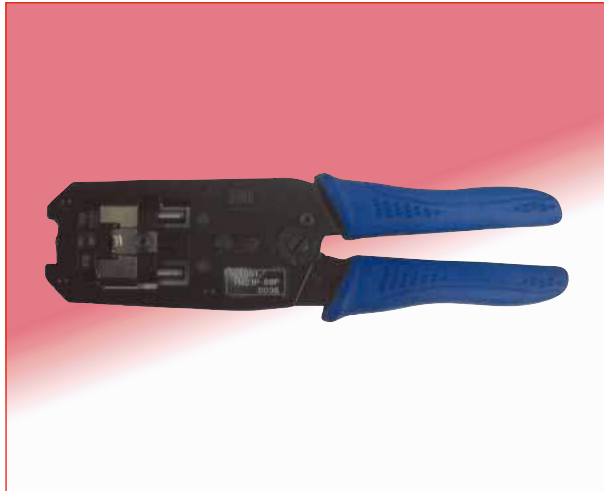

Part Number	CL No.	Applicable connector
HT601 / TM21P-88P	902-2133-1	TM21P-88P TM21CP-88P

● For contact/conductor termination (Non-shielded connectors)

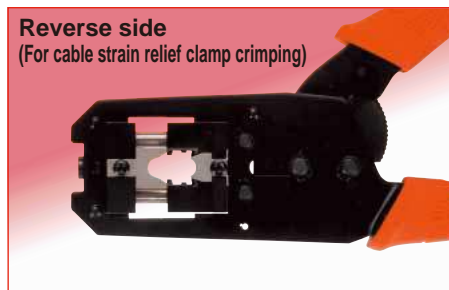

Part Number	CL No.	Applicable connector
HT601-TM23/22P-88P	CL902-2128-1	TM22P-88P
		TM23P-88P

◆ Technical Documentation

● CAT5e Transmission Characteristics Data

These are the representative values of the various transmission characteristics data for connector assemblies TM21P-88P and TM21R-5C-88-LP when fully mated.

• Signal Attenuation

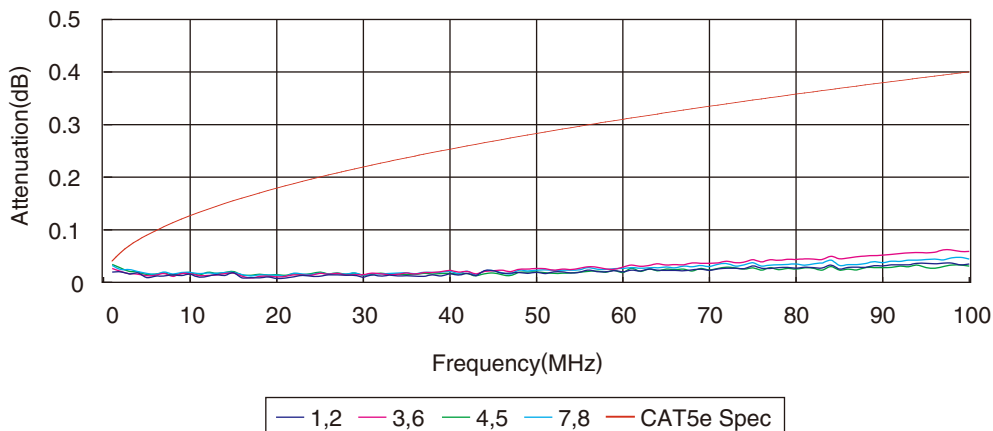

(Each two numbers are for the pair of individual contact position.)

• Near-End Crosstalk Attenuation (NEXT)

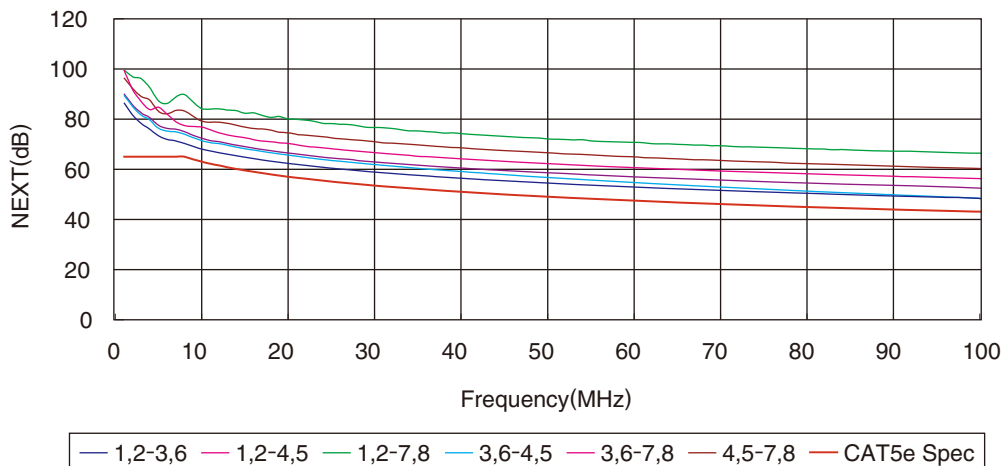

• Return Loss

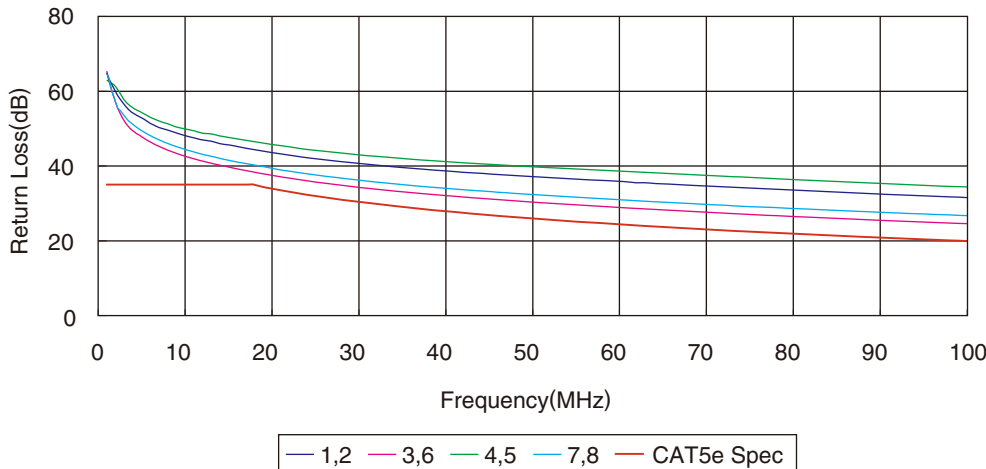

• Far-End Crosstalk Attenuation (FEXT)

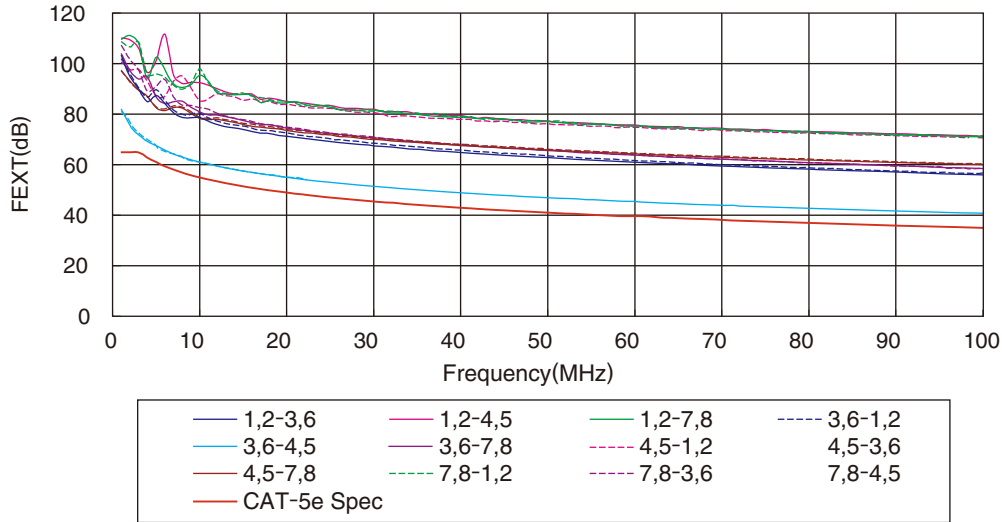

(Each two numbers are for pair of individual contact position.)

• Propagation Delay

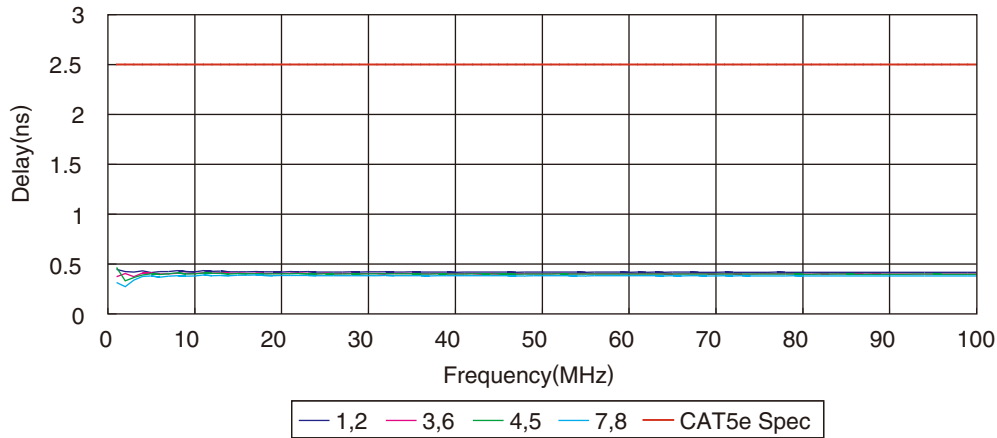

• Propagation Delay skew

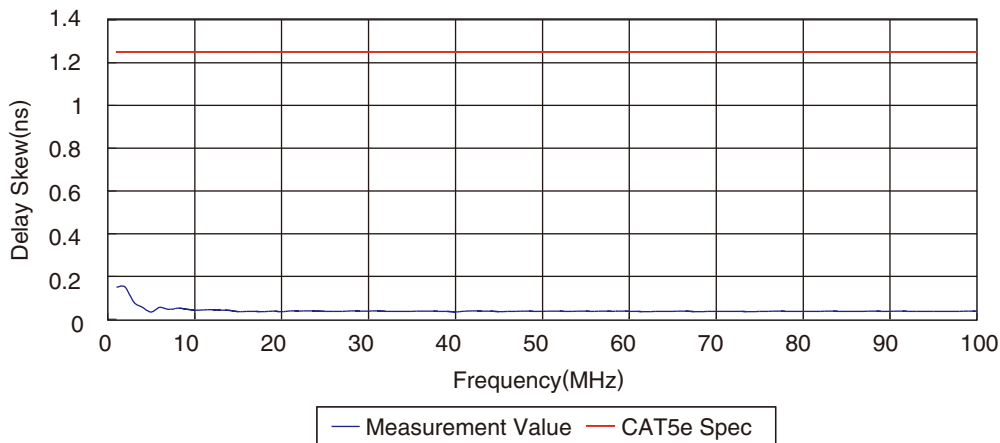

HIROSE ELECTRIC CO.,LTD.

5-23,OSAKI 5-CHOME,SHINAGAWA-KU,TOKYO 141-8587,JAPAN
 PHONE: 81-3-3491-9741, FAX: 81-3-3493-2933
<http://www.hirose.com>
<http://www.hirose-connectors.com>