

Silicon Photodiode in Top-View PLCC-2 Package



OP980

Features:

- Wide acceptance angle, 100°
- Fast response time
- Linear response vs Irradiance
- Plastic leadless chip carrier (PLCC-2)
- Low Capacitance
- Top Sensing Area
- Tape and reel packaging
- Moisture Sensitivity Level: MSL2 or >



Description:

The **OP980** is a high speed, low-noise and high sensitivity PIN silicon photodiode mounted in a miniature SMD package. The device has a flat window lens, which enables a wide acceptance angle at 100°. Due to its clear lens, the OP980 responds to visible and near infrared light. It is packaged in a plastic leadless chip carrier that is compatible with most automated pick and place mounting equipment. *The OP980 is mechanically and spectrally matched to the OP280 and OP180 infrared LED.*

Applications:

- Non-contact position sensing
- Datum detection
- Computer peripherals
- Smoke detectors
- Touch Sensors
- Machine automation
- Optical encoders
- Reflective sensors
- Counters and sorters
- Miniature optical switches

Ordering Information		
Part Number	Sensor	Viewing Angle
OP980	Photodiode	100°

Package Outline Dimensions

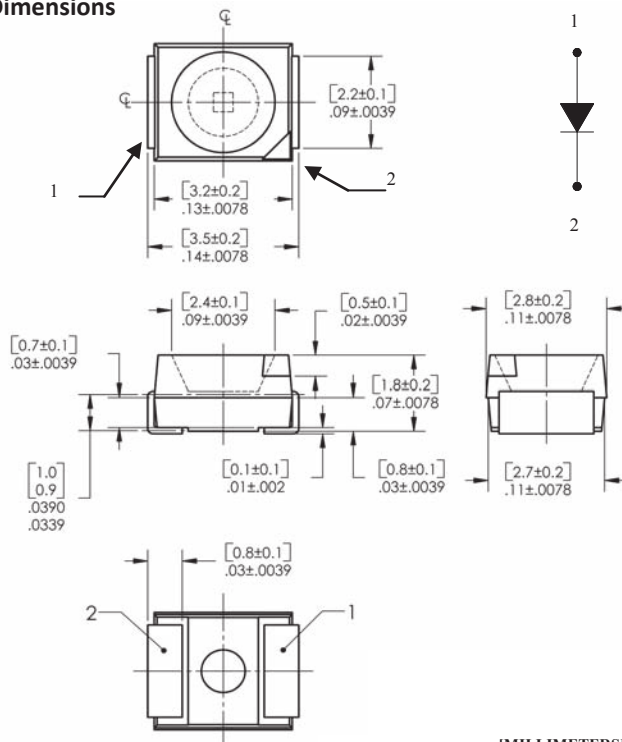

Recommended Solder Patterns

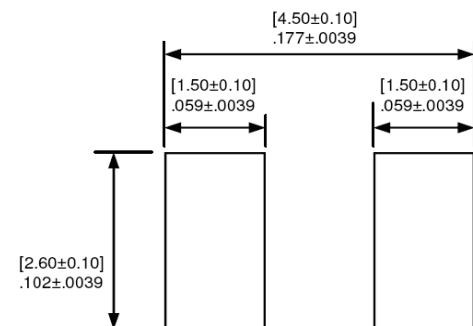

Pin #	Transistor
1	Anode
2	Cathode



DIMENSIONS ARE IN: [MILLIMETERS]
[INCHES]

General Note
TT Electronics reserves the right to make changes in product specification without notice or liability. All information is subject to TT Electronics' own data and is considered accurate at time of going to print.

OPTEK Technology, Inc.
1645 Wallace Drive, Carrollton, TX 75006 | Ph: +1 972 323 2200
www.optekinc.com | www.ttelectronics.com

Silicon Photodiode in Top-View PLCC-2 Package



OP980

Absolute Maximum Ratings ($T_A = 25^\circ\text{C}$ unless otherwise noted)						
Storage Temperature Range						-40° C to +100° C
Operating Temperature Range						-25° C to +85° C
Lead Soldering Temperature						260° C ⁽¹⁾
Electrical Characteristics ($T_A = 25^\circ\text{C}$ unless otherwise noted)						
SYMBOL	PARAMETER	MIN	TYP	MAX	UNITS	TEST CONDITIONS
I_L	Light Current	0.5	-	-	μA	$V_R = 5.0\text{ V}, E_E = 1.0\text{ mW/cm}^2$ ⁽³⁾
I_D	Dark Current	-	-	60	nA	$V_R = 30.0\text{ V}, E_E = 0.0\text{ mW/cm}^2$ ⁽³⁾
$V_{R(BR)}$	Reverse Breakdown Voltage	60	-	-	V	$I_R = 10\ \mu\text{A}$
V_F	Forward Voltage	-	-	1.2	V	$I_F = 1\text{ mA}, E_e = 0.0\text{ mW/cm}^2$
λ_{pk}	Peak Sensitivity Wavelength	-	890	-	nm	$V_R = 5.0$
t_r	Rise Time	-	50	-	ns	$V_R = 5.0, R_L = 1\text{ k}$
t_f	Fall Time	-	50	-	ns	$V_R = 5.0, R_L = 1\text{ k}$

Notes:

- Solder time less than 5 seconds at temperature extreme.
- Derate linearly at 1.33 mW/° C above 25° C.
- $E_{e(APT)}$ is an unfiltered GaAlAs LED with peak emission wavelength of 890nm. The measurement of the apertured radiant incidence upon a sensing area 0.081" (2.06mm) in diameter, perpendicular to and centered on the mechanical axis of the lens, and 0.590" (14.99mm) from the measurement surface. Measurement surface will be considered the tip of the top-view lens. $E_{e(APT)}$ is not necessarily uniform within the measured area.

Electrical Characteristic Performance Curves

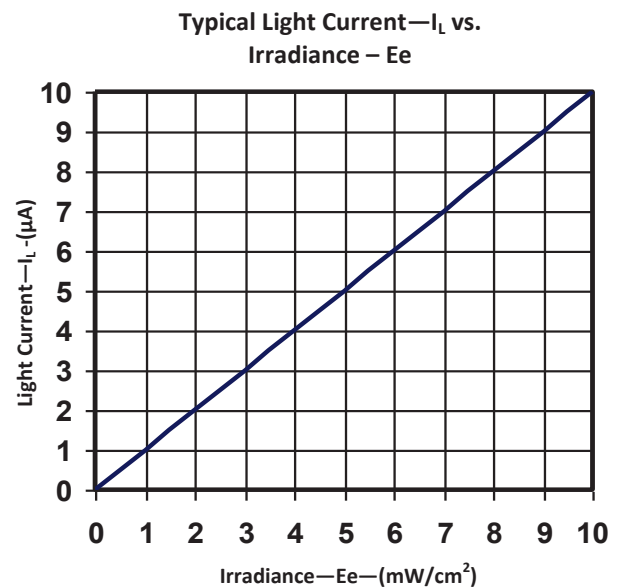
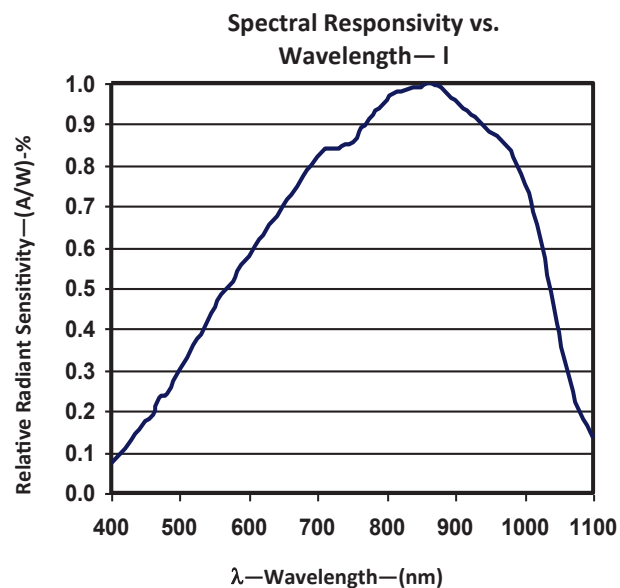

General Note
TT Electronics reserves the right to make changes in product specification without notice or liability. All information is subject to TT Electronics' own data and is considered accurate at time of going to print.

OPTEK Technology, Inc.
1645 Wallace Drive, Carrollton, TX 75006 | Ph: +1 972 323 2200
www.optekinc.com | www.ttelectronics.com

Silicon Photodiode in Top-View PLCC-2 Package



OP980

More Typical Performance Curves

Total Capacitance— C_T (pF) vs.
Reverse Bias Voltage— V_R (V)

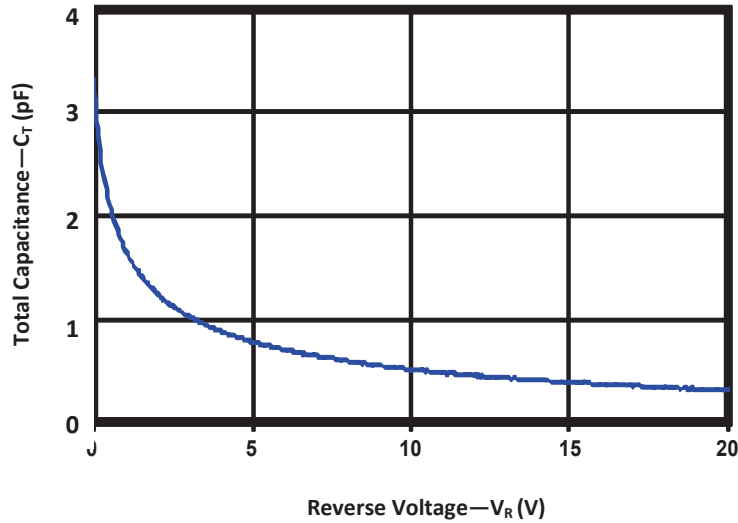

Dark Current— I_D vs.
Irradiance

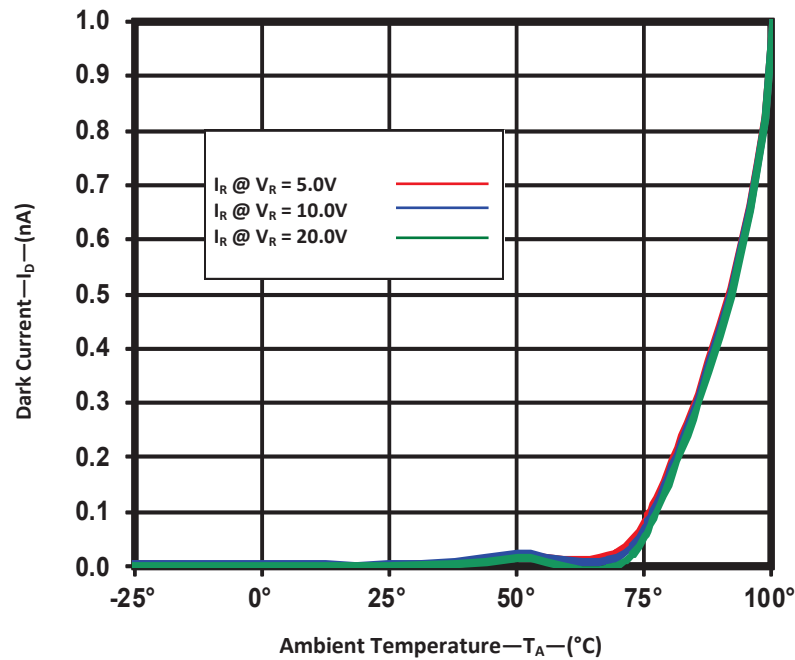

General Note
TT Electronics reserves the right to make changes in product specification without notice or liability. All information is subject to TT Electronics' own data and is considered accurate at time of going to print.

OPTEK Technology, Inc.
1645 Wallace Drive, Carrollton, TX 75006 | Ph: +1 972 323 2200
www.optekinc.com | www.ttelectronics.com

Silicon Photodiode in Top-View PLCC-2 Package



OP980

Packaging

Reel Packaging Dimensions

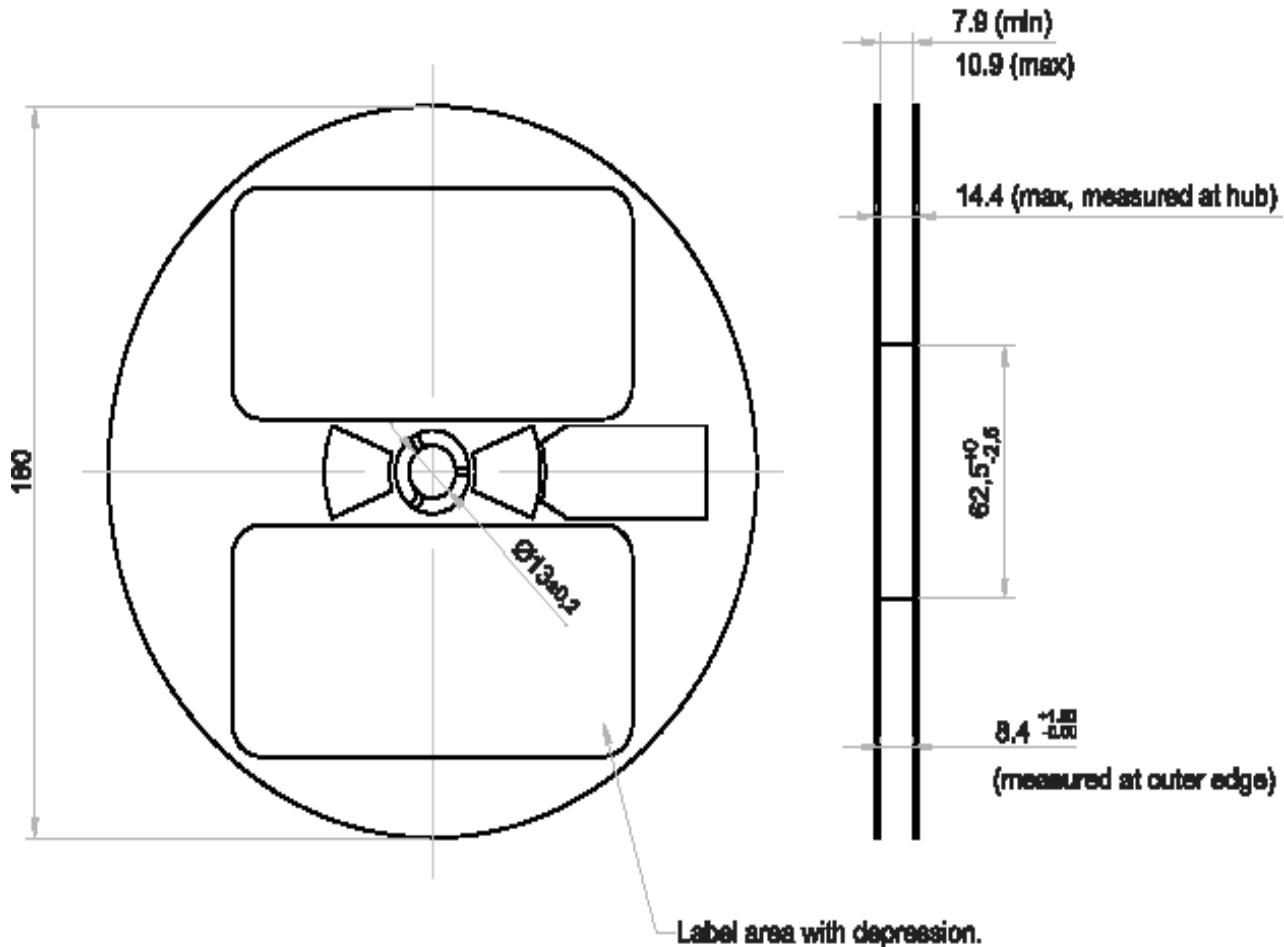

Dimensions are in: mm
Tolerance: ±0.01

General Note
TT Electronics reserves the right to make changes in product specification without notice or liability. All information is subject to TT Electronics' own data and is considered accurate at time of going to print.

OPTEK Technology, Inc.
1645 Wallace Drive, Carrollton, TX 75006 | Ph: +1 972 323 2200
www.optekinc.com | www.ttelectronics.com

Silicon Photodiode in Top-View PLCC-2 Package



OP980

Taping and Orientation

- Reels come in quantity of 2000 units.
- Reel diameter is 180mm.

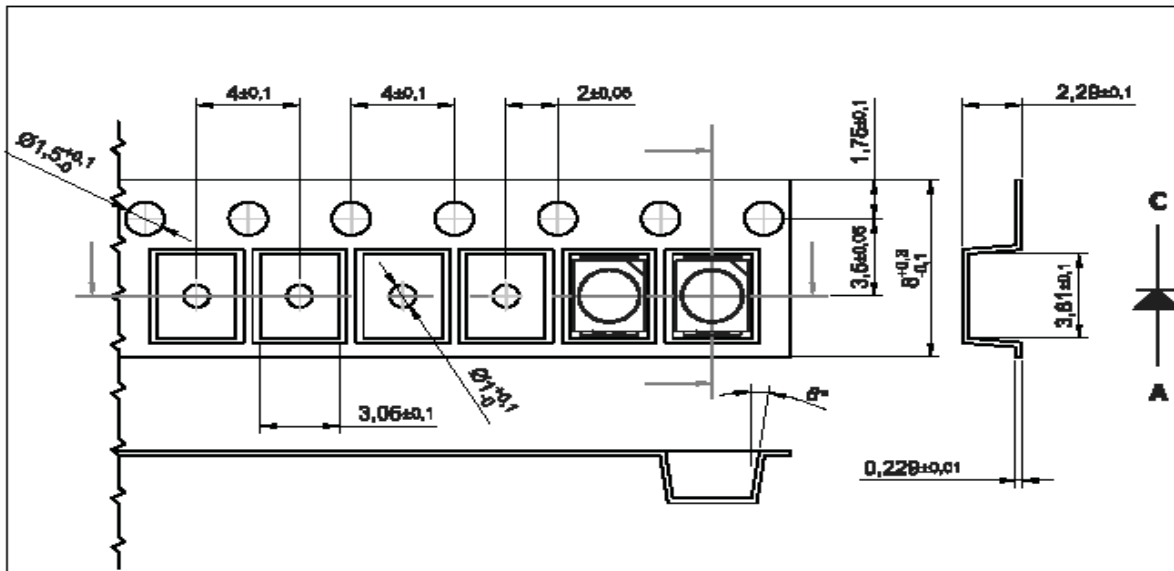

Tape Feed Direction

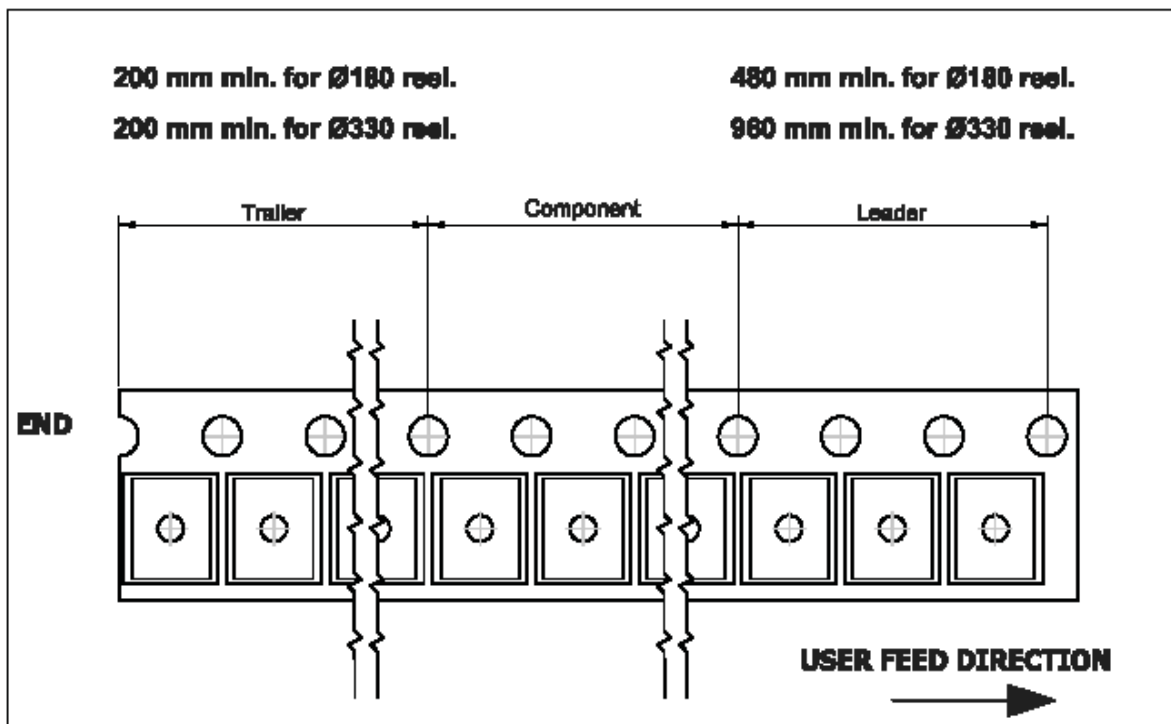

General Note
TT Electronics reserves the right to make changes in product specification without notice or liability. All information is subject to TT Electronics' own data and is considered accurate at time of going to print.

OPTEK Technology, Inc.
1645 Wallace Drive, Carrollton, TX 75006 | Ph: +1 972 323 2200
www.optekinc.com | www.ttelectronics.com