

- 1
- 2
- 3
- 4
- 5
- 6
- 7
- 8
- 9
- 10
- 11
- 12
- 13
- 14
- 15
- 16
- 17
- 18

BASE

Glass-fibre reinforced polyamide based (PA) technopolymer, black colour, matte finish.

ARTICULATED THROUGH STEM

Threaded zinc-plated steel with regulation hexagon.
Assembled to the base by means of zinc-plated steel set screw and washer.

CUP WASHER FOR STEM BEARING

Glossy zinc-plated steel.

STANDARD EXECUTIONS

- **LV.A-ACV**: without no-slip disk.
- **LV.A-ACV-AS**: with NBR rubber no-slip disk, hardness 90 Shore A, supplied assembled with reinforced zinc-plated steel plate fixed by means of two screws.

FEATURES

The special knurling under the lower lip of the base provides excellent stability and grip when using the levelling element without no-slip disk even on surfaces that are not perfectly flat.

The components of the levelling elements (base and stem) are supplied already assembled.

ACCESSORIES ON REQUEST

Zinc-plated steel nut (see Nuts NT. on page 1283).

SPECIAL EXECUTIONS ON REQUEST

AISI 304 stainless steel stems.



ELESA Original design

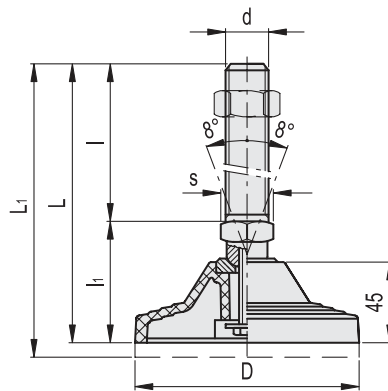

| Conversion Table | |
|-------------------|------|
| 1 mm = 0.039 inch | |
| D | |
| mm | inch |
| 125 | 4.92 |

LV.A-ACV

LV.A-ACV-AS

METRIC

| Code | Description | Code | Description | D | d | L | L1# | l | li | s | Max. limit stati load* [N] | ⚖️ | ⚖️ # |
|--------|----------------------|--------|-------------------------|-----|-----|-----|-----|-----|----|----|----------------------------|------|------|
| 306921 | LV.A-125-ACV-M20x136 | 310921 | LV.A-125-ACV-AS-M20x136 | 125 | M20 | 200 | 210 | 136 | 64 | 24 | 40000 | 580 | 830 |
| 306925 | LV.A-125-ACV-M20x186 | 310925 | LV.A-125-ACV-AS-M20x186 | 125 | M20 | 250 | 260 | 186 | 64 | 24 | 40000 | 690 | 940 |
| 306931 | LV.A-125-ACV-M24x136 | 310931 | LV.A-125-ACV-AS-M24x136 | 125 | M24 | 200 | 210 | 136 | 64 | 24 | 40000 | 730 | 980 |
| 306935 | LV.A-125-ACV-M24x186 | 310935 | LV.A-125-ACV-AS-M24x186 | 125 | M24 | 250 | 260 | 186 | 64 | 24 | 40000 | 840 | 1090 |
| 306941 | LV.A-125-ACV-M30x136 | 310941 | LV.A-125-ACV-AS-M30x136 | 125 | M30 | 200 | 210 | 136 | 64 | 30 | 40000 | 940 | 1190 |
| 306945 | LV.A-125-ACV-M30x186 | 310945 | LV.A-125-ACV-AS-M30x186 | 125 | M30 | 250 | 260 | 186 | 64 | 30 | 40000 | 1030 | 1280 |

* The max static load is the value above which the load applied to the element may cause some plastic material breakage, in particular conditions of use. Obviously, a factor that takes into consideration the importance and the safety level of the specific application must be applied to this value.

Data with no-slip disk mounted.