

bq24780S EVM

The bq24780S evaluation module (EVM) is an SMBus 1- to 4-cell hybrid power boost mode battery charge controller with power and processor hot monitoring. The input voltage range is between 4.5 V and 24 V, with a programmable output of 1–4 cells charge voltage and 128-mA to 8.128-A charge current. This EVM does not include the EV2400 interface device; it must be ordered separately to evaluate the bq24780S EVM.

Contents

1	Introduction	3
1.1	EVM Features	3
1.2	I/O Descriptions	3
1.3	Controls and Key Parameters Setting	3
1.4	Recommended Operating Conditions	3
2	Test Summary	4
2.1	Equipment	4
2.2	Equipment Setup.....	5
3	Procedure	7
3.1	AC Adapter Detection Threshold	7
3.2	Charger Parameter Settings.....	7
3.3	Charge Current and AC Current Regulation (DPM).....	7
3.4	Boost Mode	9
3.5	Power Path Selection	9
4	PCB Layout Guideline	10
5	Board Layout, Schematic, and Bill of Materials	11
5.1	PWR583 PCB Layouts	11
5.2	Schematics	14
5.3	Bill of Materials	15

List of Figures

1	Connections of the EV2400 Kit	5
2	Original Test Setup for PWR583 (bq24780S EVM)	6
3	Main Window of bq24780S Evaluation Software	6
4	Test Setup for PWR583.....	8
5	Top Assembly.....	11
6	Top Layer.....	11
7	Mid-Layer 1	12
8	Mid-Layer 2	12
9	Bottom Layer.....	13
10	Bottom Assembly.....	13
11	bq24780SEVM-583 Schematic.....	14

List of Tables

1	I/O Descriptions	3
2	Controls and Key Parameters Setting	3
3	Recommended Operating Conditions	3

Microsoft, Windows are registered trademarks of Microsoft Corporation.

4	EV2400 and bq24780S EVM Connections	5
5	bq24780SEVM-583 Bill of Materials	15

1 Introduction

1.1 EVM Features

Refer to the data sheet ([SLUSC27](#)) for detailed features and operation.

1.2 I/O Descriptions

[Table 1](#) lists the I/O descriptions.

Table 1. I/O Descriptions

Jack	Description
J1– DCIN	Connect to AC adapter positive output
J1– GND	Connect to AC adapter, negative output
J2 – SYS	Connect to system
J2 – GND	Power ground, same as J1 – GND
J2 – BAT	Connect to battery positive
J3 – 1 GND	Analog ground
J3 – 2 SDA	Communication interface
J3 – 3 SCL	
J3 – 4 3V3	External 3.3-V power supply
J3 – 5 CMPIN	Integrated comparator input (pin 13)
J3 – 6 CMPOUT	Integrated comparator output (pin 14)

1.3 Controls and Key Parameters Setting

[Table 2](#) lists the controls and key parameter settings of the EVM.

Table 2. Controls and Key Parameters Setting

Jack	Description	Factory Setting
JP1	Connect battery positive input (BAT) to TPS3898 SENSE pin through resistor divider (R33/R34)	Jumper not installed
JP2	Connect REGN to TPS3898 VCC pin	Jumper not installed
JP3	Connect BAT to bq24780 CMPIN pin through resistor divider (R35/R36)	Jumper not installed
JP4	Connect bq24780 CMPOUT to bq24780/BATPRES pin	Jumper not installed
JP5	Connect TPS3898/SENSE_OUT pin to bq24780/BATPRES pin	Jumper not installed
JP6	Connect battery positive input (BAT) to diode D1	Jumper Installed

1.4 Recommended Operating Conditions

[Table 3](#) provides the recommended operating conditions.

Table 3. Recommended Operating Conditions

Description		MIN	TYP	MAX	UNIT
$V_{IN}^{(1)}$	Supply voltage	18	19–20	23	V
V_{BAT}	Battery voltage		3–16.8	17.408	V
I_{AC}	Supply current			4.5	A
I_S	Output current			8	A
T_J	Operating junction temperature range	0		125	°C

⁽¹⁾ ACDET bias, R5 and R6, is set for this range. For lower adapter voltages, this divider has to be modified. With the proper bias, $V_{IN\ MIN}$ can be as low as 4.5 VDC. See the data sheet ([SLUSC27](#)) for more information.

2 Test Summary

[Section 2.1](#) and [Section 2.2](#) explain the equipment and the equipment setup.

2.1 Equipment

2.1.1 Power Supplies

Power Supply #1 (PS#1): a power supply capable of supplying 20 V at 5 A is required.

Power Supply #2 (PS#2): a power supply capable of supplying 5 V at 1 A is required.

Power Supply #3 (PS#3): a power supply capable of supplying 20 V at 3 A is required.

2.1.2 Loads

LOAD #1: A 30 V (or above), 5-A (or above) electronic load that can operate at constant current mode.

LOAD #2: An HP 6060B 3–60 V/0–60 A, 300-W system DC electronic load, or equivalent.

2.1.3 Meters

Seven Fluke 75 multimeters, (equivalent or better), or four equivalent voltage meters and three equivalent current meters.

The current meters must be capable of measuring 5 A+ current.

2.1.4 Computer

A computer with at least one USB port and a USB cable. The EV2400 USB driver and the bq24780 SMB evaluation software must be properly installed.

2.1.5 SMBUS Communication Kit

This EVM is compatible with both the EV2400 and EV2300 hardware kit. TI recommends using the EV2400 hardware kit.

2.1.6 Install Battery Management Studio (bqStudio) Software

Double click the *Battery Management Studio software* installation file, follow the installation steps.

2.1.7 Upon First Insertion of EV2400 Into USB Port of PC

Follow the instructions of the *Found New Hardware Wizard*

- Allow Microsoft® Windows® to connect to Windows Update to search for software, then click *Next*
- Select *Install software automatically (Recommended)*, then click *Next*
- If a window pops up informing that the TI USB Firmware Updater has not passed Windows Logo testing click *Continue Anyway*
- If a target file already exists **and** is newer, do not overwrite the newer file
- Click *Finish*

2.2 Equipment Setup

- Set power supply #1 (PS#1) for 0 V ±100 mVDC, with the current limit set to > 5 A. Turn off supply.
- Connect PS#1 output in series with a current meter (multimeter) to J1 (VIN, GND)
- Connect a voltage meter across J1 (VIN, GND)
- Set power supply #2 (PS#2) for 3.3 V ±100 mVDC, with the current limit set to > 0.2 A. Turn off supply.
- Connect PS#2 output to J3 (3V3, GND)
- Connect a voltage meter across J2 (BAT, GND)
- Connect a voltage meter across J2 (SYS, GND)
- Connect J3 (SDA, SCL) and J3 (GND) to the EV2400 kit *SMB* port. Refer to [Table 4](#) for EVM connections. Connect the USB port of the EV2400 kit to the USB port of the computer. The connections are shown in [Figure 2](#).

Table 4. EV2400 and bq24780S EVM Connections

bq24780S EVM	EV2400
GND (J3)	VSS 1.1
SCL (J3)	SCL 1.2
SDA (J3)	SDA 1.3

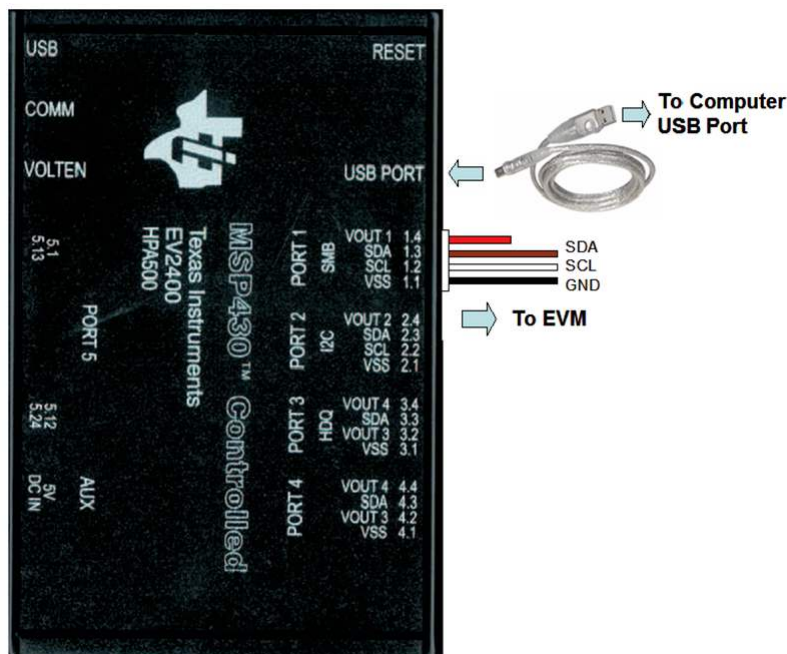

Figure 1. Connections of the EV2400 Kit

After completing the previous steps, the test setup for PWR583 appears as shown in Figure 2.

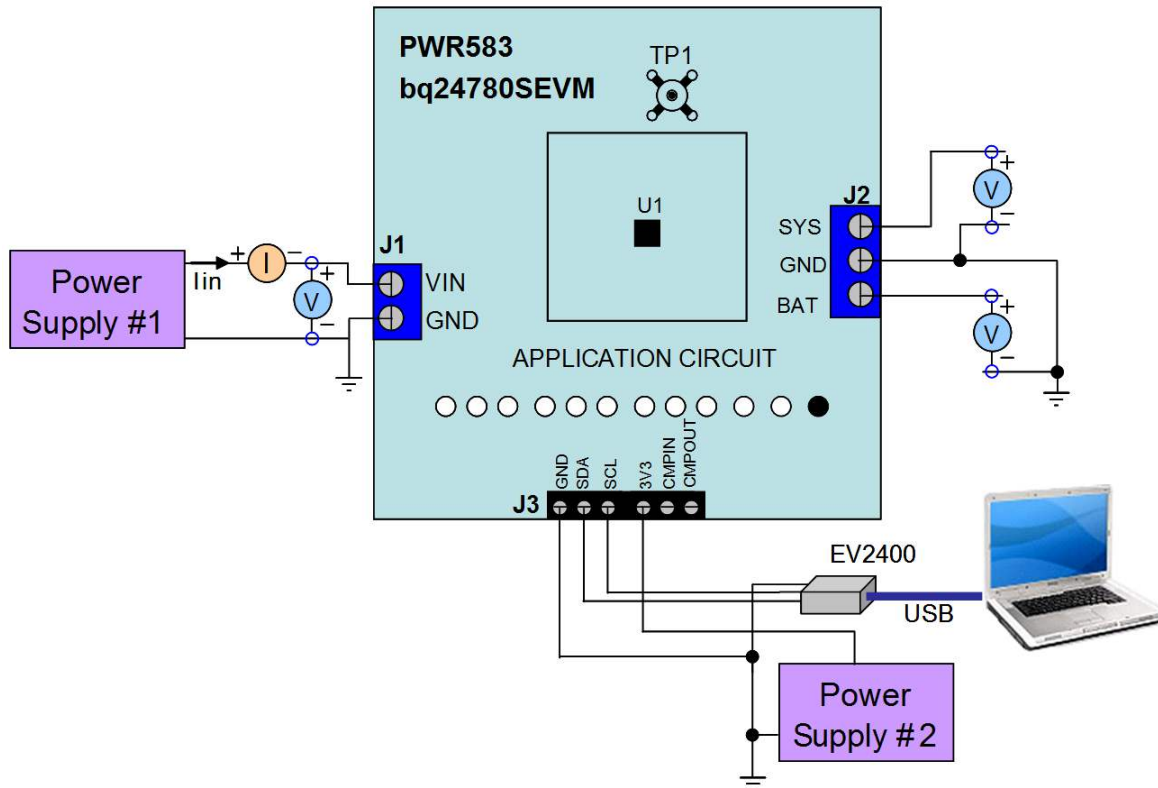

Figure 2. Original Test Setup for PWR583 (bq24780S EVM)

Turn on the computer. Launch the bqstudio evaluation software and select *charger* and *bq24780S*. And then click the *Registers* button. The main window of the bq24780S software is shown in Figure 3.

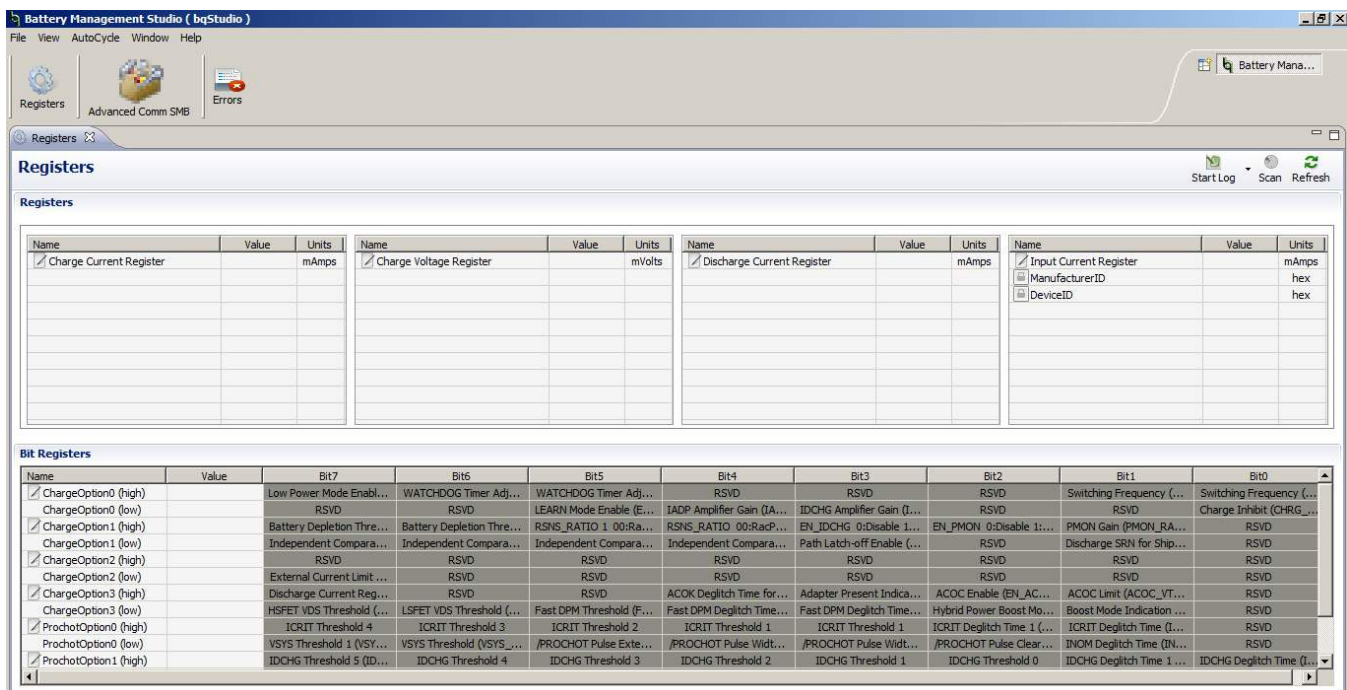

Figure 3. Main Window of bq24780S Evaluation Software

3 Procedure

3.1 AC Adapter Detection Threshold

Use the following steps for AC adapter detection threshold:

1. Ensure [Equipment Setup](#) steps are followed. Turn on PS#2.

NOTE: Load #1 and Load #2 are not connected during this step.

2. Turn on PS#1
3. Increase the output voltage of PS#1 to 19.5 V
 - Measure → V[TP(ACDET)] = 2.6 V ±0.1 V
 - Measure → V[TP(ACOK)] = 3.3 V ±0.1 V
 - Measure → V[J2(SYS)] = 19.5 V ±0.5 V
 - Measure → V[TP(REGN)] = 5.4 V ±0.5 V
 - Measure → V[TP(ACDRV, CMSRC)] = 6 V ±0.5 V
 - Measure → V[J2(BAT, GND)] = 2 V ±2 V

3.2 Charger Parameter Settings

In the main software window, click the *Refresh* button on the top right corner. Make sure there is no error information.

Type “512” (mA) in *ChargeCurrent* Register and click *OK*. This sets the battery charge current regulation threshold.

Type “12592” (mV) in *ChargeVoltage* Register and click *OK*. This sets the battery voltage regulation threshold:

- Measure → V(J2(BAT)) = 12.6 V ±200 mV

3.3 Charge Current and AC Current Regulation (DPM)

1. Connect Load #2 in series with a current meter (multimeter) to J2 (BAT, GND). Make sure a voltage meter is connected across J2 (BAT, GND). Turn on Load #2. Use the constant voltage mode. Set output voltage to 10.5 V.
2. Connect the output of Load #1 in series with a current meter (multimeter) to J2 (SYS, GND). Make sure a voltage meter is connected across J2 (SYS, GND). Turn on the power of Load #1.

The setup is now like [Figure 4](#) for PWR583.

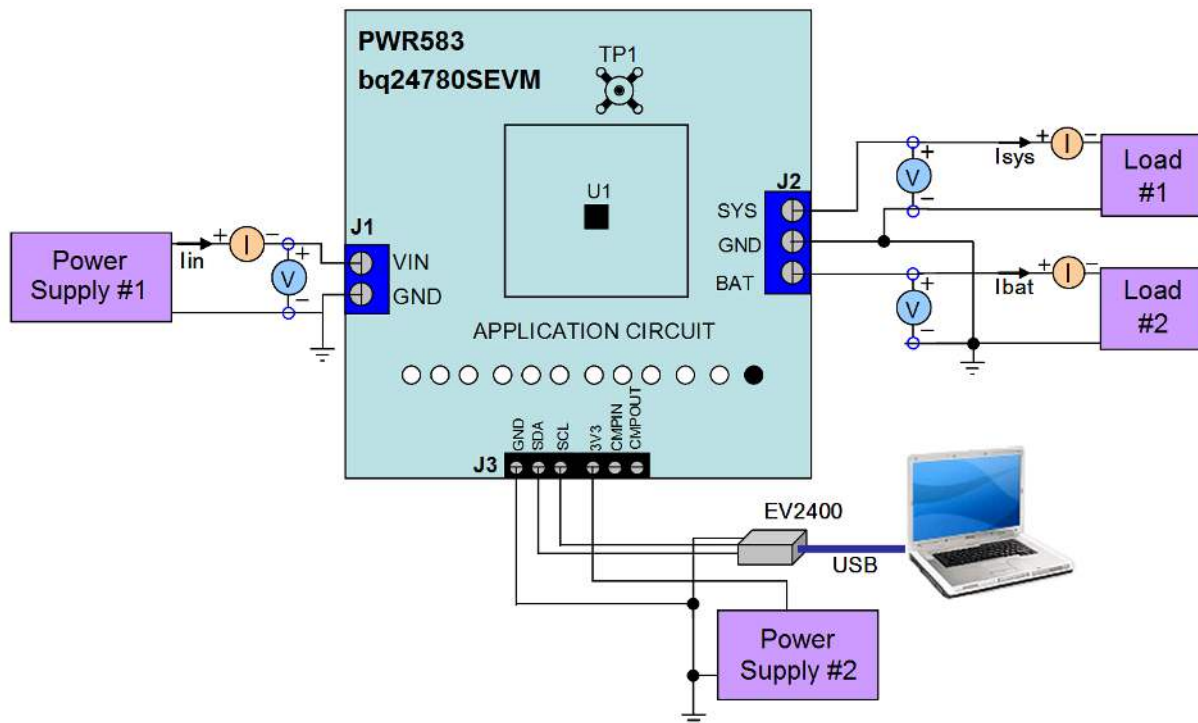

Figure 4. Test Setup for PWR583

3. Type "2944" (mA) in *ChargeCurrent* Register and click *OK*.
This sets the battery charge current regulation threshold to 2.944 A.
 - Measure → IBAT = 3000 mA ±300 mA
 - Measure → V[TP(I_{IADP})] = 340 mV ±40 mV
4. Set Load #1 current to 3.0 A ±50 mA but disable the output. Make sure ISYS = 0 A ±10 mA. Enable the output of Load #1.
 - Measure → ISYS = 3000 mA ±300 mA
 - Measure → IBAT = 1800 mA ±300 mA
 - Measure → IIN = 4100 mA ±400 mA
 - Measure → V[TP(I_{IADP})] = 820 mV ±100 mV
5. Turn off the Load #1.
 - Measure → ISYS = 0 ±100 mA
 - IBAT = 3000 mA ±300 mA

3.4 Boost Mode

Use the following steps for boost mode:

1. Enter "1A44" in *ChargeOption3* value to enable the turbo boost function
2. Change Load #2 with PS#3. Make sure a voltage meter is connected across J2 (BAT, GND).
3. Enable the output of PS#3. Make sure the output voltage is 10 V \pm 500 mV and 3-A current limit.
4. Set Load #1 load current to 5.0 A \pm 50 mA. Enter boost mode.
 - Measure \rightarrow ISYS = 5000 mA \pm 500 mA
 - Measure \rightarrow IBAT = -1700 mA \pm 300 mA
 - Measure \rightarrow IIN = 4100 mA \pm 400 mA
 - Measure \rightarrow V[TP(I_{ADP})] = 820 mV \pm 100 mV
 - Measure \rightarrow V[TP(I_{IDCHG})] = 270 mV \pm 100 mV
5. Set Load #1 load current to 0.5 A \pm 50 mA. Exit boost mode. Back to charging mode.
 - Measure \rightarrow ISYS = 500 mA \pm 50 mA
 - Measure \rightarrow IBAT = 3000 mA \pm 300 mA
 - Measure \rightarrow IIN = 2100 mA \pm 400 mA

3.5 Power Path Selection

The setup for power path selection follows:

1. Change Load #2 with PS#3. Make sure a voltage meter is connected across J2 (BAT, GND)
2. Enable the output of PS#3. Ensure the output voltage is 10 V \pm 500 mV and 3-A current limit.
3. Set Load #1 load current to 0.5 A \pm 50 mA
4. Enter "E109" in *ChargeOption0*, this disables charging
5. Make sure a voltage meter is connected across J2 (BAT, GND)
 - Measure \rightarrow V(J2(SYS)) = 19.5 V \pm 1 V (adapter connected to system)
6. Turn off PS#1
 - Measure \rightarrow V[J2(SYS)] = 10 V \pm 1 V (battery connected to system)
 - Measure \rightarrow V[J2(BAT)] = 10 V \pm 1 V (battery connected to system)

4 PCB Layout Guideline

The switching node rise and fall times should be minimized for minimum switching loss. Proper layout of the components to minimize high frequency current path loop is important to prevent electrical and magnetic field radiation and high-frequency resonant problems. Here is a PCB layout priority list for proper layout. Layout of the PCB according to this specific order is essential.

1. Place input capacitor as close as possible to switching MOSFET's supply and ground connections and use the shortest possible copper trace connection. These parts should be placed on the same layer of PCB instead of on different layers and using vias to make this connection.
2. The IC should be placed close to the switching MOSFET's gate pins and keep the gate drive signal traces short for a clean MOSFET drive. The IC can be placed on the other side of the PCB from the switching MOSFETs.
3. Place the inductor input pin to the switching MOSFET's output pin as close as possible. Minimize the copper area of this trace to lower electrical and magnetic field radiation but make the trace wide enough to carry the charging current. Do not use multiple layers in parallel for this connection. Minimize parasitic capacitance from this area to any other trace or plane.
4. The charging current sensing resistor should be placed right next to the inductor output. Route the sense leads connected across the sensing resistor back to the IC in same layer, close to each other (minimize loop area) and do not route the sense leads through a high-current path. Place decoupling capacitor on these traces next to the IC.
5. Place the output capacitor next to the sensing resistor output and ground.
6. Output capacitor ground connections need to be tied to the same copper that connects to the input capacitor ground before connecting to system ground.
7. Use a single ground connection to tie charger power ground to charger analog ground. Just beneath the IC, use analog ground copper pour but avoid power pins to reduce inductive and capacitive noise coupling.
8. Route analog ground separately from power ground. Connect analog ground and connect power ground separately. Connect analog ground and power ground together using the power pad as the single ground connection point or using a 0- Ω resistor to tie analog ground to power ground (power pad should tie to analog ground in this case, if possible).
9. Decoupling capacitors should be placed next to the IC pins and make the trace connection as short as possible.
10. It is critical that the exposed power pad on the backside of the IC package be soldered to the PCB ground. Ensure that there are sufficient thermal vias directly under the IC, connecting to the ground plane on the other layers.
11. The via size and number should be enough for a given current path.

See the EVM design for the recommended component placement with trace and via locations. For the WQFN information, see [SCBA017](#) and [SLUA271](#).

5 Board Layout, Schematic, and Bill of Materials

This section contains the [PWR583 PCB layouts](#), [schematics](#), and [bill of materials](#).

5.1 PWR583 PCB Layouts

Figure 5 through Figure 10 show the PCB layouts for the PWR583 EVM.

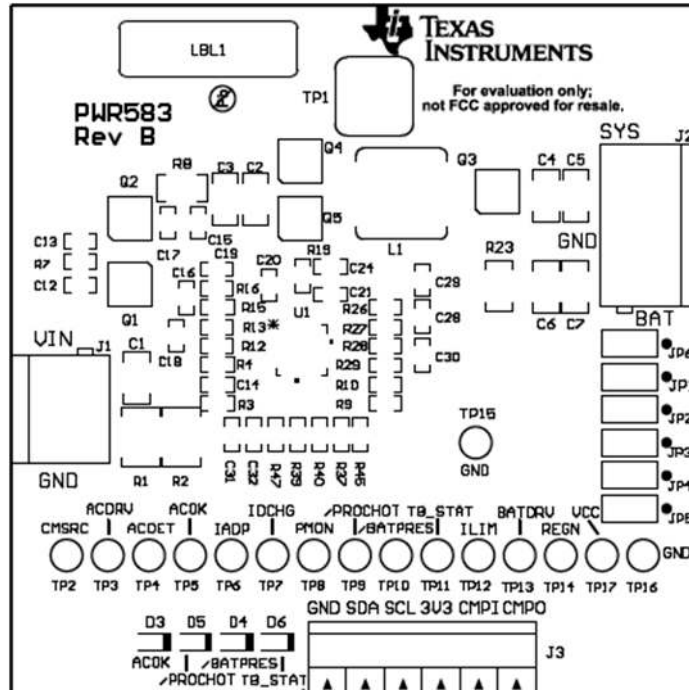

Figure 5. Top Assembly

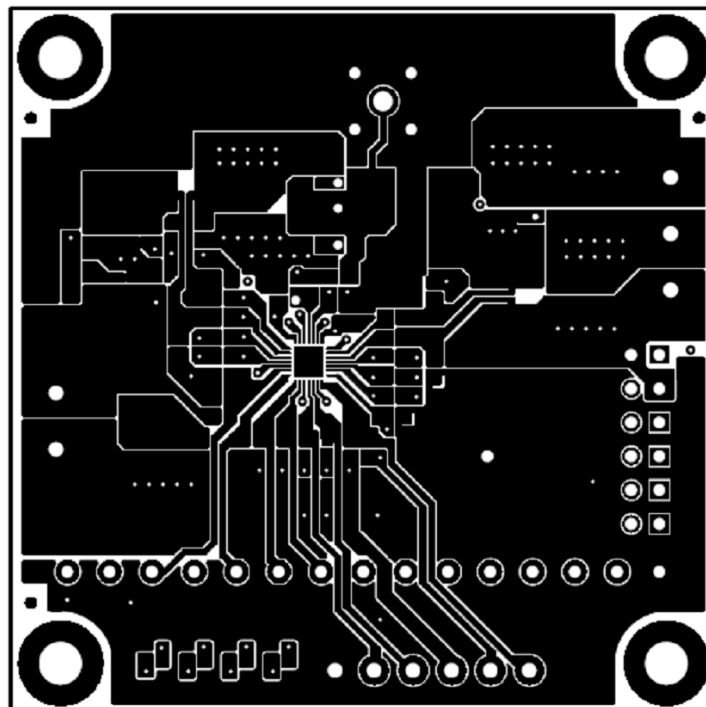

Figure 6. Top Layer

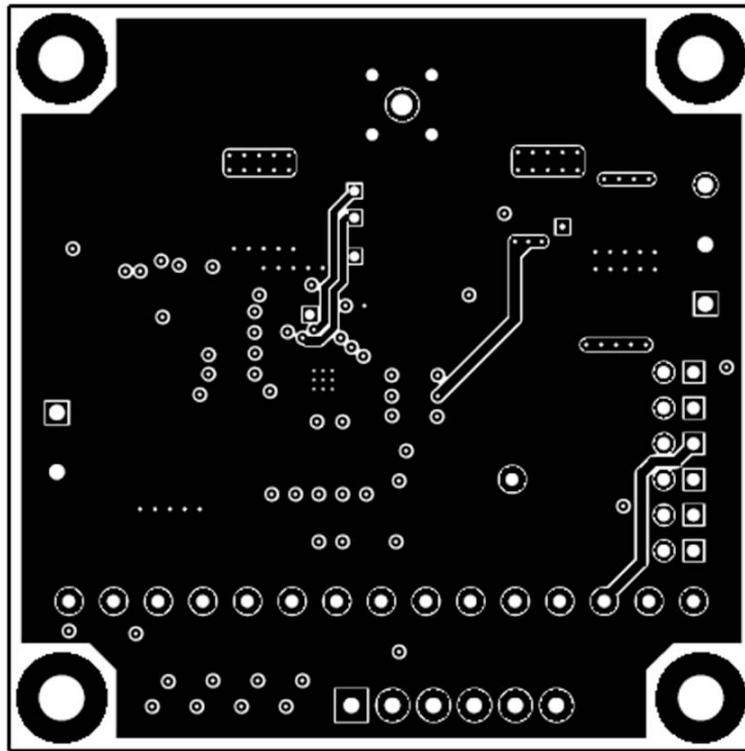

Figure 7. Mid-Layer 1

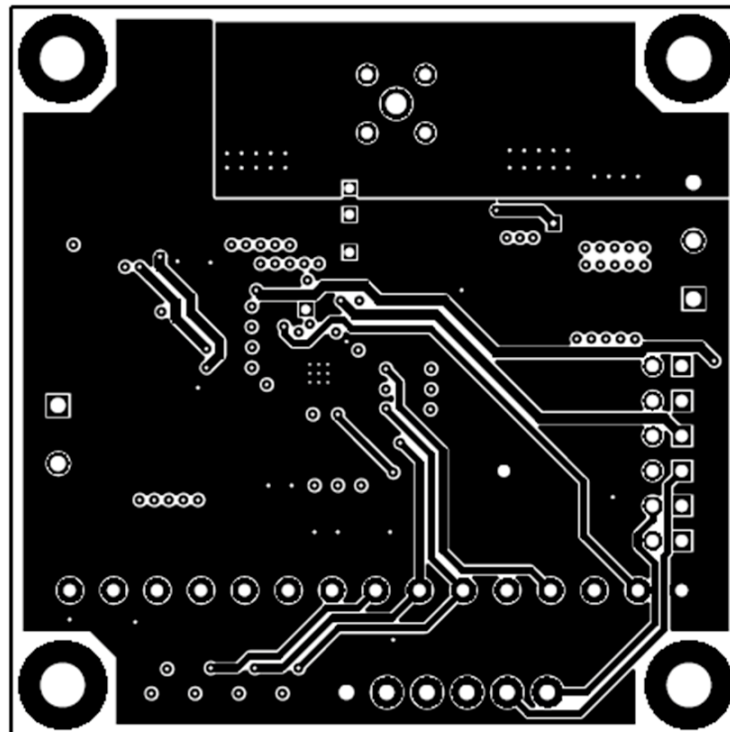

Figure 8. Mid-Layer 2

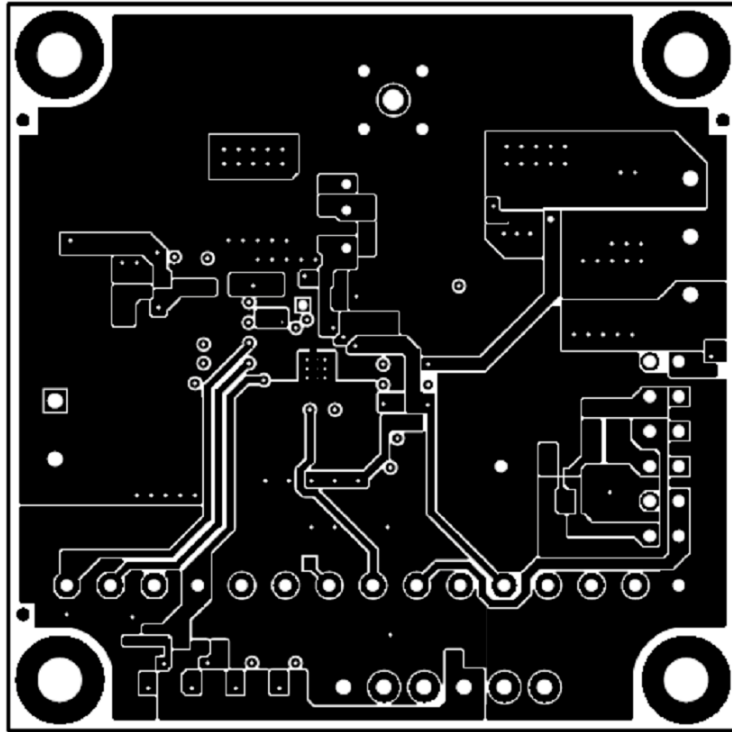

Figure 9. Bottom Layer

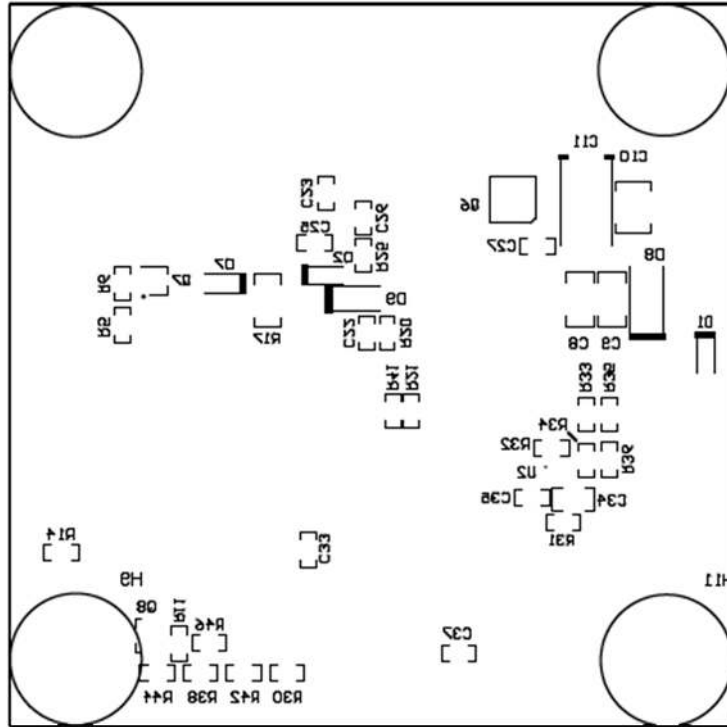

Figure 10. Bottom Assembly

5.2 Schematics

The bq24780SEVM-583 (Figure 11) schematic is provided for reference.

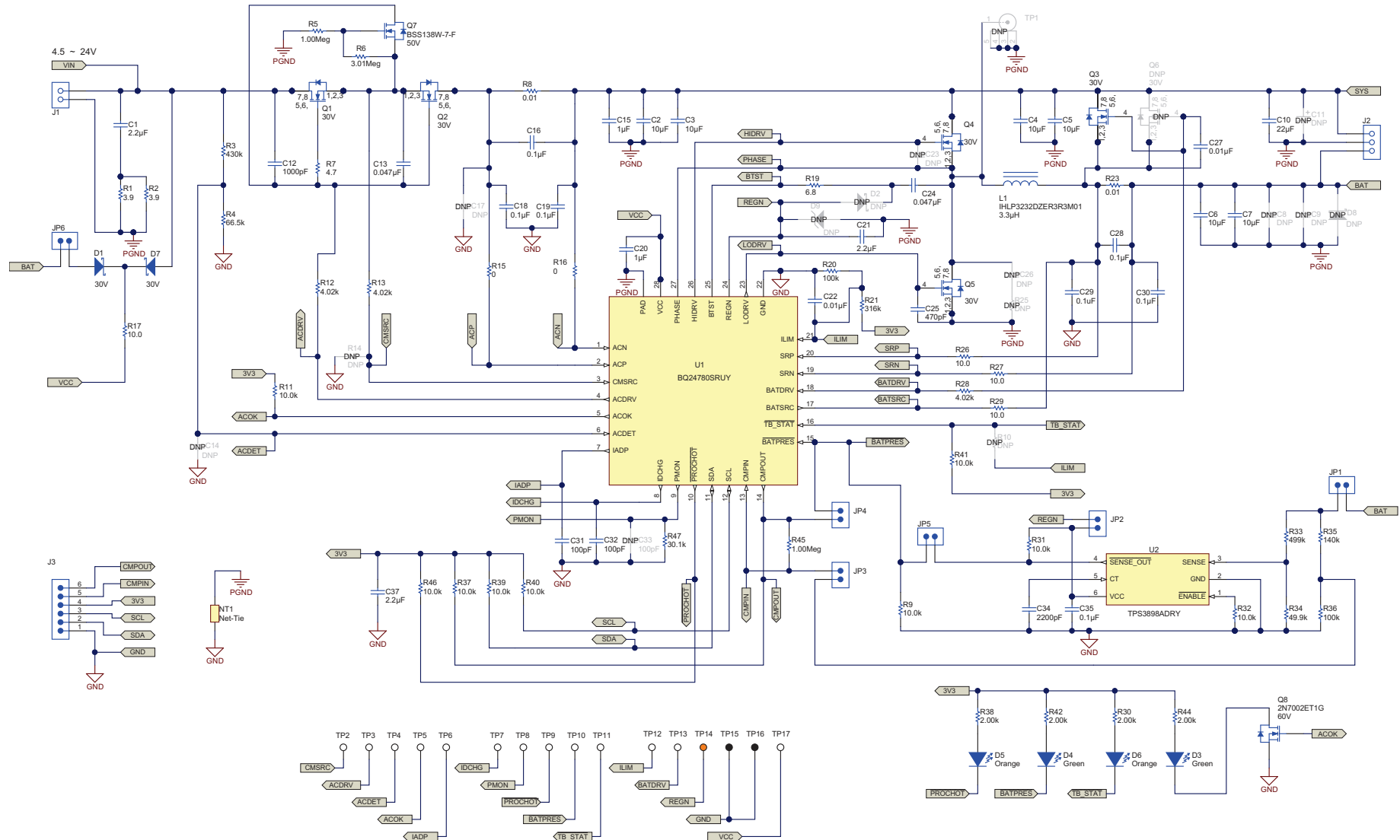

Figure 11. bq24780SEVM-583 Schematic

5.3 Bill of Materials

Table 5 lists the bq24780SEVM-583 BOM.

Table 5. bq24780SEVM-583 Bill of Materials

Designator	Qty	Value	Description	Package Reference	PartNumber	Manufacturer
!PCB	1		Printed Circuit Board		PWR583	Any
C1	1	2.2uF	CAP, CERM, 2.2uF, 25V, +/-10%, X7R, 1206	1206	GRM31MR71E225KA93L	MuRata
C2, C3, C4, C5, C6, C7	6	10uF	CAP, CERM, 10uF, 25V, +/-10%, X5R, 1206	1206	GRM31CR61E106KA12L	MuRata
C10	1	22uF	CAP, CERM, 22uF, 25V, +/-10%, X5R, 1210	1210	GRM32ER61E226KE15L	MuRata
C12	1	1000pF	CAP, CERM, 1000pF, 50V, +/-10%, X7R, 0603	0603	GRM188R71H102KA01D	MuRata
C13, C24	2	0.047uF	CAP, CERM, 0.047uF, 50V, +/-10%, X7R, 0603	0603	GRM188R71H473KA61D	MuRata
C15, C20	2	1uF	CAP, CERM, 1uF, 25V, +/-10%, X7R, 0603	0603	GRM188R71E105KA12D	MuRata
C16, C18, C19, C28, C29, C30, C35	7	0.1uF	CAP, CERM, 0.1uF, 25V, +/-10%, X7R, 0603	0603	GRM188R71E104KA01D	MuRata
C21	1	2.2uF	CAP, CERM, 2.2uF, 16V, +/-10%, X5R, 0603	0603	GRM188R61C225KE15D	MuRata
C22, C27	2	0.01uF	CAP, CERM, 0.01uF, 50V, +/-10%, X7R, 0603	0603	C0603X103K5RACTU	Kemet
C25	1	470pF	CAP, CERM, 470pF, 50V, +/-10%, X7R, 0603	0603	GRM188R71H471KA01D	MuRata
C31, C32	2	100pF	CAP, CERM, 100pF, 50V, +/-5%, C0G/NP0, 0603	0603	C0603C101J5GAC	Kemet
C34	1	2200pF	CAP, CERM, 2200pF, 50V, +/-5%, C0G/NP0, 0805	0805	C2012C0G1H222J	TDK
C37	1	2.2uF	CAP, CERM, 2.2uF, 10V, +/-10%, X7R, 0603	0603	GRM188R71A225KE15D	MuRata
D1, D7	2	30V	Diode, Schottky, 30V, 0.2A, SOD-323	SOD-323	BAT54HT1G	ON Semiconductor
D3, D4	2	Green	LED, Green, SMD	1.6x0.8x0.8mm	LTST-C190GKT	Lite-On
D5, D6	2	Orange	LED, Orange, SMD	1.6x0.8x0.8mm	LTST-C190KFKT	Lite-On
H9, H10, H11, H12	4		Bumpon, Hemisphere, 0.44 X 0.20, Clear	Transparent Bumpon	SJ-5303 (CLEAR)	3M
J1	1		TERMINAL BLOCK 5.08MM VERT 2POS	TERM_BLK, 2pos, 5.08mm	ED120/2DS	On-Shore Technology, Inc.
J2	1		TERMINAL BLOCK 5.08MM VERT 3POS	TERM_BLK, 3pos, 5.08mm	ED120/3DS	On-Shore Technology, Inc.
J3	1		Terminal Block, 6A, 3.5mm Pitch, 6-Pos, TH	20.5x8.2x6.5mm	ED555/6DS	On-Shore Technology, Inc.
JP1, JP2, JP3, JP4, JP5, JP6	6		Header, 100mil, 2x1, Gold plated, TH	Header, 2x1, 100mil	5-146261-1	TE Connectivity
L1	1	3.3uH	Inductor, Shielded, Powdered Iron, 3.3uH, 9.2A, 17.7 ohm, SMD	322x158x322mil	IHLP3232DZER3R3M01	Vishay-Dale
LBL1	1		Thermal Transfer Printable Labels, 0.650" W x 0.200" H - 10,000 per roll	PCB Label 0.650"H x 0.200"W	THT-14-423-10	Brady
Q1, Q2, Q3, Q4, Q5	5	30V	MOSFET, N-CH, 30V, 47A, SON 3.3x3.3mm	SON 3.3x3.3mm	CSD17308Q3	Texas Instruments
Q7	1	50V	MOSFET, N-CH, 50V, 0.2A, SOT-323	SOT-323	BSS138W-7-F	Diodes Inc.
Q8	1	60V	MOSFET, N-CH, 60V, 0.26A, SOT-23	SOT-23	2N7002ET1G	ON Semiconductor
R1, R2	2	3.9	RES, 3.9 ohm, 5%, 0.5W, 1210	1210	ERJ-14YJ3R9U	Panasonic
R3	1	430k	RES, 430k ohm, 1%, 0.1W, 0603	0603	RC0603FR-07430KL	Yageo America
R4	1	66.5k	RES, 66.5k ohm, 1%, 0.1W, 0603	0603	CRCW060366K5FKEA	Vishay-Dale
R5, R45	2	1.00Meg	RES, 1.00Meg ohm, 1%, 0.1W, 0603	0603	CRCW06031M00FKEA	Vishay-Dale
R6	1	3.01Meg	RES, 3.01Meg ohm, 1%, 0.1W, 0603	0603	CRCW06033M01FKEA	Vishay-Dale
R7	1	4.7	RES, 4.7 ohm, 5%, 0.1W, 0603	0603	CRCW06034R70JNEA	Vishay-Dale
R8, R23	2	0.01	RES, 0.01 ohm, 1%, 1W, 1206	1206	WSP1206R0100FEA	Vishay-Dale
R9, R11, R31, R32, R37, R39, R40, R41, R46	9	10.0k	RES, 10.0k ohm, 1%, 0.1W, 0603	0603	CRCW060310K0FKEA	Vishay-Dale
R12, R13, R28	3	4.02k	RES, 4.02k ohm, 1%, 0.1W, 0603	0603	CRCW06034K02FKEA	Vishay-Dale
R15, R16	2	0	RES, 0 ohm, 5%, 0.1W, 0603	0603	CRCW06030000Z0EA	Vishay-Dale
R17	1	10.0	RES, 10.0 ohm, 1%, 0.25W, 1206	1206	ERJ-8ENF10R0V	Panasonic
R19	1	6.8	RES, 6.8 ohm, 5%, 0.1W, 0603	0603	CRCW06036R80JNEA	Vishay-Dale
R20, R36	2	100k	RES, 100k ohm, 5%, 0.1W, 0603	0603	CRCW0603100KJNEA	Vishay-Dale
R21	1	316k	RES, 316k ohm, 1%, 0.1W, 0603	0603	CRCW0603316KFKEA	Vishay-Dale
R26, R27, R29	3	10.0	RES, 10.0 ohm, 1%, 0.1W, 0603	0603	RC0603FR-0710RL	Yageo America
R30, R38, R42, R44	4	2.00k	RES, 2.00k ohm, 1%, 0.1W, 0603	0603	CRCW06032K00FKEA	Vishay-Dale
R33	1	499k	RES, 499k ohm, 1%, 0.1W, 0603	0603	CRCW0603499KFKEA	Vishay-Dale

Table 5. bq24780SEVM-583 Bill of Materials (continued)

Designator	Qty	Value	Description	Package Reference	PartNumber	Manufacturer
R34	1	49.9k	RES, 49.9k ohm, 1%, 0.1W, 0603	0603	CRCW060349K9FKEA	Vishay-Dale
R35	1	140k	RES, 140k ohm, 1%, 0.1W, 0603	0603	CRCW0603140KFKEA	Vishay-Dale
R47	1	30.1k	RES, 30.1k ohm, 1%, 0.1W, 0603	0603	CRCW060330K1FKEA	Vishay-Dale
TP2, TP3, TP4, TP5, TP6, TP7, TP8, TP9, TP10, TP11, TP12, TP13, TP17	13	White	Test Point, TH, Miniature, White	Keystone5002	5002	Keystone
TP14	1	Orange	Test Point, Miniature, Orange, TH	Orange Miniature Testpoint	5003	Keystone
TP15, TP16	2	Black	Test Point, Miniature, Black, TH	Black Miniature Testpoint	5001	Keystone
U1	1		1-4 Cell Turbo Boost Mode Battery Charge Controller with Power Monitoring and /PROCHOT for CPU Throttling, RUY0028A	RUY0028A	BQ24780SRUY	Texas Instruments
U2	1		Single-Channel, Adjustable Supervisory Circuit in Ultra-Small Package, DRY0006A	DRY0006A	TPS3898ADRY	Texas Instruments
C8, C9	0	10uF	CAP, CERM, 10uF, 25V, +/-10%, X5R, 1206	1206	GRM31CR61E106KA12L	MuRata
C11	0	150uF	CAP, TA, 150uF, 16V, +/-20%, 0.05 ohm, SMD	7.3x2.8x4.3mm	16TQC150MYF	Panasonic
C14, C26	0	DNP	CAP, CERM, 0.1uF, 25V, +/-10%, X7R, 0603	0603	GRM188R71E104KA01D	MuRata
C17	0	1uF	CAP, CERM, 1uF, 25V, +/-10%, X7R, 0603	0603	GRM188R71E105KA12D	MuRata
C23	0	0.1uF	CAP, CERM, 0.1uF, 25V, +/-10%, X7R, 0603	0603	GRM188R71E104KA01D	MuRata
C33	0	100pF	CAP, CERM, 100pF, 50V, +/-5%, C0G/NP0, 0603	0603	C0603C101J5GAC	Kemet
D2	0	DNP	Diode, Schottky, 30V, 0.2A, SOD-323	SOD-323	BAT54HT1G	ON Semiconductor
D8	0	DNP	Diode, Schottky, 20V, 1A, SMA	SMA	SS12-E3/61T	Vishay-Semiconductor
D9	0	8.2V	Diode, Zener, 8.2V, 500mW, SOD-123	SOD-123	BZT52C8V2-7-F	Diodes Inc.
FID1, FID2, FID3	0		Fiducial mark. There is nothing to buy or mount.	Fiducial	N/A	N/A
H1, H2, H3, H4	0		Machine Screw, Round, #4-40 x 1/4, Nylon, Philips panhead	Screw	NY PMS 440 0025 PH	B&F Fastener Supply
H5, H6, H7, H8	0		Standoff, Hex, 0.5"L #4-40 Nylon	Standoff	1902C	Keystone
Q6	0	30V	MOSFET, N-CH, 30V, 47A, SON 3.3x3.3mm	SON 3.3x3.3mm	CSD17308Q3	Texas Instruments
R10	0	DNP	RES, 84.5k ohm, 0.1%, 0.1W, 0603	0603	RG1608P-8452-B-T5	Susumu Co Ltd
R14	0	DNP	RES, 0 ohm, 5%, 0.1W, 0603	0603	CRCW0603000Z0EA	Vishay-Dale
R25	0	DNP	RES, 100k ohm, 1%, 0.1W, 0603	0603	CRCW0603100KFKEA	Vishay-Dale
TP1	0		Compact Probe Tip Circuit Board Test Points, TH, 25 per	TH Scope Probe	131-5031-00	Tektronix

STANDARD TERMS AND CONDITIONS FOR EVALUATION MODULES

1. *Delivery:* TI delivers TI evaluation boards, kits, or modules, including any accompanying demonstration software, components, or documentation (collectively, an "EVM" or "EVMs") to the User ("User") in accordance with the terms and conditions set forth herein. Acceptance of the EVM is expressly subject to the following terms and conditions.
 - 1.1 EVMs are intended solely for product or software developers for use in a research and development setting to facilitate feasibility evaluation, experimentation, or scientific analysis of TI semiconductors products. EVMs have no direct function and are not finished products. EVMs shall not be directly or indirectly assembled as a part or subassembly in any finished product. For clarification, any software or software tools provided with the EVM ("Software") shall not be subject to the terms and conditions set forth herein but rather shall be subject to the applicable terms and conditions that accompany such Software
 - 1.2 EVMs are not intended for consumer or household use. EVMs may not be sold, sublicensed, leased, rented, loaned, assigned, or otherwise distributed for commercial purposes by Users, in whole or in part, or used in any finished product or production system.
2. *Limited Warranty and Related Remedies/Disclaimers:*
 - 2.1 These terms and conditions do not apply to Software. The warranty, if any, for Software is covered in the applicable Software License Agreement.
 - 2.2 TI warrants that the TI EVM will conform to TI's published specifications for ninety (90) days after the date TI delivers such EVM to User. Notwithstanding the foregoing, TI shall not be liable for any defects that are caused by neglect, misuse or mistreatment by an entity other than TI, including improper installation or testing, or for any EVMs that have been altered or modified in any way by an entity other than TI. Moreover, TI shall not be liable for any defects that result from User's design, specifications or instructions for such EVMs. Testing and other quality control techniques are used to the extent TI deems necessary or as mandated by government requirements. TI does not test all parameters of each EVM.
 - 2.3 If any EVM fails to conform to the warranty set forth above, TI's sole liability shall be at its option to repair or replace such EVM, or credit User's account for such EVM. TI's liability under this warranty shall be limited to EVMs that are returned during the warranty period to the address designated by TI and that are determined by TI not to conform to such warranty. If TI elects to repair or replace such EVM, TI shall have a reasonable time to repair such EVM or provide replacements. Repaired EVMs shall be warranted for the remainder of the original warranty period. Replaced EVMs shall be warranted for a new full ninety (90) day warranty period.
3. *Regulatory Notices:*
 - 3.1 *United States*
 - 3.1.1 *Notice applicable to EVMs not FCC-Approved:*

This kit is designed to allow product developers to evaluate electronic components, circuitry, or software associated with the kit to determine whether to incorporate such items in a finished product and software developers to write software applications for use with the end product. This kit is not a finished product and when assembled may not be resold or otherwise marketed unless all required FCC equipment authorizations are first obtained. Operation is subject to the condition that this product not cause harmful interference to licensed radio stations and that this product accept harmful interference. Unless the assembled kit is designed to operate under part 15, part 18 or part 95 of this chapter, the operator of the kit must operate under the authority of an FCC license holder or must secure an experimental authorization under part 5 of this chapter.
 - 3.1.2 *For EVMs annotated as FCC – FEDERAL COMMUNICATIONS COMMISSION Part 15 Compliant:*

CAUTION

This device complies with part 15 of the FCC Rules. Operation is subject to the following two conditions: (1) This device may not cause harmful interference, and (2) this device must accept any interference received, including interference that may cause undesired operation.

Changes or modifications not expressly approved by the party responsible for compliance could void the user's authority to operate the equipment.

FCC Interference Statement for Class A EVM devices

NOTE: This equipment has been tested and found to comply with the limits for a Class A digital device, pursuant to part 15 of the FCC Rules. These limits are designed to provide reasonable protection against harmful interference when the equipment is operated in a commercial environment. This equipment generates, uses, and can radiate radio frequency energy and, if not installed and used in accordance with the instruction manual, may cause harmful interference to radio communications. Operation of this equipment in a residential area is likely to cause harmful interference in which case the user will be required to correct the interference at his own expense.

FCC Interference Statement for Class B EVM devices

NOTE: This equipment has been tested and found to comply with the limits for a Class B digital device, pursuant to part 15 of the FCC Rules. These limits are designed to provide reasonable protection against harmful interference in a residential installation. This equipment generates, uses and can radiate radio frequency energy and, if not installed and used in accordance with the instructions, may cause harmful interference to radio communications. However, there is no guarantee that interference will not occur in a particular installation. If this equipment does cause harmful interference to radio or television reception, which can be determined by turning the equipment off and on, the user is encouraged to try to correct the interference by one or more of the following measures:

- Reorient or relocate the receiving antenna.
- Increase the separation between the equipment and receiver.
- Connect the equipment into an outlet on a circuit different from that to which the receiver is connected.
- Consult the dealer or an experienced radio/TV technician for help.

3.2 Canada

3.2.1 For EVMs issued with an Industry Canada Certificate of Conformance to RSS-210

Concerning EVMs Including Radio Transmitters:

This device complies with Industry Canada license-exempt RSS standard(s). Operation is subject to the following two conditions: (1) this device may not cause interference, and (2) this device must accept any interference, including interference that may cause undesired operation of the device.

Concernant les EVMs avec appareils radio:

Le présent appareil est conforme aux CNR d'Industrie Canada applicables aux appareils radio exempts de licence. L'exploitation est autorisée aux deux conditions suivantes: (1) l'appareil ne doit pas produire de brouillage, et (2) l'utilisateur de l'appareil doit accepter tout brouillage radioélectrique subi, même si le brouillage est susceptible d'en compromettre le fonctionnement.

Concerning EVMs Including Detachable Antennas:

Under Industry Canada regulations, this radio transmitter may only operate using an antenna of a type and maximum (or lesser) gain approved for the transmitter by Industry Canada. To reduce potential radio interference to other users, the antenna type and its gain should be so chosen that the equivalent isotropically radiated power (e.i.r.p.) is not more than that necessary for successful communication. This radio transmitter has been approved by Industry Canada to operate with the antenna types listed in the user guide with the maximum permissible gain and required antenna impedance for each antenna type indicated. Antenna types not included in this list, having a gain greater than the maximum gain indicated for that type, are strictly prohibited for use with this device.

Concernant les EVMs avec antennes détachables

Conformément à la réglementation d'Industrie Canada, le présent émetteur radio peut fonctionner avec une antenne d'un type et d'un gain maximal (ou inférieur) approuvé pour l'émetteur par Industrie Canada. Dans le but de réduire les risques de brouillage radioélectrique à l'intention des autres utilisateurs, il faut choisir le type d'antenne et son gain de sorte que la puissance isotrope rayonnée équivalente (p.i.r.e.) ne dépasse pas l'intensité nécessaire à l'établissement d'une communication satisfaisante. Le présent émetteur radio a été approuvé par Industrie Canada pour fonctionner avec les types d'antenne énumérés dans le manuel d'usage et ayant un gain admissible maximal et l'impédance requise pour chaque type d'antenne. Les types d'antenne non inclus dans cette liste, ou dont le gain est supérieur au gain maximal indiqué, sont strictement interdits pour l'exploitation de l'émetteur.

3.3 Japan

3.3.1 *Notice for EVMs delivered in Japan:* Please see http://www.tij.co.jp/lstds/ti_ja/general/eStore/notice_01.page 日本国内に輸入される評価用キット、ボードについては、次のところをご覧ください。
http://www.tij.co.jp/lstds/ti_ja/general/eStore/notice_01.page

3.3.2 *Notice for Users of EVMs Considered "Radio Frequency Products" in Japan:* EVMs entering Japan may not be certified by TI as conforming to Technical Regulations of Radio Law of Japan.

If User uses EVMs in Japan, not certified to Technical Regulations of Radio Law of Japan, User is required by Radio Law of Japan to follow the instructions below with respect to EVMs:

1. Use EVMs in a shielded room or any other test facility as defined in the notification #173 issued by Ministry of Internal Affairs and Communications on March 28, 2006, based on Sub-section 1.1 of Article 6 of the Ministry's Rule for Enforcement of Radio Law of Japan,
2. Use EVMs only after User obtains the license of Test Radio Station as provided in Radio Law of Japan with respect to EVMs, or
3. Use of EVMs only after User obtains the Technical Regulations Conformity Certification as provided in Radio Law of Japan with respect to EVMs. Also, do not transfer EVMs, unless User gives the same notice above to the transferee. Please note that if User does not follow the instructions above, User will be subject to penalties of Radio Law of Japan.

【無線電波を送信する製品の開発キットをお使いになる際の注意事項】 開発キットの中には技術基準適合証明を受けていないものがあります。技術適合証明を受けていないものご使用に際しては、電波法遵守のため、以下のいずれかの措置を取っていただく必要がありますのでご注意ください。

1. 電波法施行規則第6条第1項第1号に基づく平成18年3月28日総務省告示第173号で定められた電波暗室等の試験設備でご使用いただく。
2. 実験局の免許を取得後ご使用いただく。
3. 技術基準適合証明を取得後ご使用いただく。

なお、本製品は、上記の「ご使用にあたっての注意」を譲渡先、移転先に通知しない限り、譲渡、移転できないものとします。

上記を遵守頂けない場合は、電波法の罰則が適用される可能性があることをご留意ください。日本テキサス・インスツルメンツ株式会社

東京都新宿区西新宿 6 丁目 2 4 番 1 号

西新宿三井ビル

3.3.3 *Notice for EVMs for Power Line Communication:* Please see http://www.tij.co.jp/llds/ti_ja/general/eStore/notice_02.page

電力線搬送波通信についての開発キットをお使いになる際の注意事項については、次のところをご覧ください。http://www.tij.co.jp/llds/ti_ja/general/eStore/notice_02.page

4 *EVM Use Restrictions and Warnings:*

4.1 EVMS ARE NOT FOR USE IN FUNCTIONAL SAFETY AND/OR SAFETY CRITICAL EVALUATIONS, INCLUDING BUT NOT LIMITED TO EVALUATIONS OF LIFE SUPPORT APPLICATIONS.

4.2 User must read and apply the user guide and other available documentation provided by TI regarding the EVM prior to handling or using the EVM, including without limitation any warning or restriction notices. The notices contain important safety information related to, for example, temperatures and voltages.

4.3 *Safety-Related Warnings and Restrictions:*

4.3.1 User shall operate the EVM within TI's recommended specifications and environmental considerations stated in the user guide, other available documentation provided by TI, and any other applicable requirements and employ reasonable and customary safeguards. Exceeding the specified performance ratings and specifications (including but not limited to input and output voltage, current, power, and environmental ranges) for the EVM may cause personal injury or death, or property damage. If there are questions concerning performance ratings and specifications, User should contact a TI field representative prior to connecting interface electronics including input power and intended loads. Any loads applied outside of the specified output range may also result in unintended and/or inaccurate operation and/or possible permanent damage to the EVM and/or interface electronics. Please consult the EVM user guide prior to connecting any load to the EVM output. If there is uncertainty as to the load specification, please contact a TI field representative. During normal operation, even with the inputs and outputs kept within the specified allowable ranges, some circuit components may have elevated case temperatures. These components include but are not limited to linear regulators, switching transistors, pass transistors, current sense resistors, and heat sinks, which can be identified using the information in the associated documentation. When working with the EVM, please be aware that the EVM may become very warm.

4.3.2 EVMs are intended solely for use by technically qualified, professional electronics experts who are familiar with the dangers and application risks associated with handling electrical mechanical components, systems, and subsystems. User assumes all responsibility and liability for proper and safe handling and use of the EVM by User or its employees, affiliates, contractors or designees. User assumes all responsibility and liability to ensure that any interfaces (electronic and/or mechanical) between the EVM and any human body are designed with suitable isolation and means to safely limit accessible leakage currents to minimize the risk of electrical shock hazard. User assumes all responsibility and liability for any improper or unsafe handling or use of the EVM by User or its employees, affiliates, contractors or designees.

4.4 User assumes all responsibility and liability to determine whether the EVM is subject to any applicable international, federal, state, or local laws and regulations related to User's handling and use of the EVM and, if applicable, User assumes all responsibility and liability for compliance in all respects with such laws and regulations. User assumes all responsibility and liability for proper disposal and recycling of the EVM consistent with all applicable international, federal, state, and local requirements.

5. *Accuracy of Information:* To the extent TI provides information on the availability and function of EVMs, TI attempts to be as accurate as possible. However, TI does not warrant the accuracy of EVM descriptions, EVM availability or other information on its websites as accurate, complete, reliable, current, or error-free.

6. *Disclaimers:*
- 6.1 EXCEPT AS SET FORTH ABOVE, EVMS AND ANY WRITTEN DESIGN MATERIALS PROVIDED WITH THE EVM (AND THE DESIGN OF THE EVM ITSELF) ARE PROVIDED "AS IS" AND "WITH ALL FAULTS." TI DISCLAIMS ALL OTHER WARRANTIES, EXPRESS OR IMPLIED, REGARDING SUCH ITEMS, INCLUDING BUT NOT LIMITED TO ANY IMPLIED WARRANTIES OF MERCHANTABILITY OR FITNESS FOR A PARTICULAR PURPOSE OR NON-INFRINGEMENT OF ANY THIRD PARTY PATENTS, COPYRIGHTS, TRADE SECRETS OR OTHER INTELLECTUAL PROPERTY RIGHTS.
- 6.2 EXCEPT FOR THE LIMITED RIGHT TO USE THE EVM SET FORTH HEREIN, NOTHING IN THESE TERMS AND CONDITIONS SHALL BE CONSTRUED AS GRANTING OR CONFERRING ANY RIGHTS BY LICENSE, PATENT, OR ANY OTHER INDUSTRIAL OR INTELLECTUAL PROPERTY RIGHT OF TI, ITS SUPPLIERS/LICENSORS OR ANY OTHER THIRD PARTY, TO USE THE EVM IN ANY FINISHED END-USER OR READY-TO-USE FINAL PRODUCT, OR FOR ANY INVENTION, DISCOVERY OR IMPROVEMENT MADE, CONCEIVED OR ACQUIRED PRIOR TO OR AFTER DELIVERY OF THE EVM.
7. *USER'S INDEMNITY OBLIGATIONS AND REPRESENTATIONS.* USER WILL DEFEND, INDEMNIFY AND HOLD TI, ITS LICENSORS AND THEIR REPRESENTATIVES HARMLESS FROM AND AGAINST ANY AND ALL CLAIMS, DAMAGES, LOSSES, EXPENSES, COSTS AND LIABILITIES (COLLECTIVELY, "CLAIMS") ARISING OUT OF OR IN CONNECTION WITH ANY HANDLING OR USE OF THE EVM THAT IS NOT IN ACCORDANCE WITH THESE TERMS AND CONDITIONS. THIS OBLIGATION SHALL APPLY WHETHER CLAIMS ARISE UNDER STATUTE, REGULATION, OR THE LAW OF TORT, CONTRACT OR ANY OTHER LEGAL THEORY, AND EVEN IF THE EVM FAILS TO PERFORM AS DESCRIBED OR EXPECTED.
8. *Limitations on Damages and Liability:*
- 8.1 *General Limitations.* IN NO EVENT SHALL TI BE LIABLE FOR ANY SPECIAL, COLLATERAL, INDIRECT, PUNITIVE, INCIDENTAL, CONSEQUENTIAL, OR EXEMPLARY DAMAGES IN CONNECTION WITH OR ARISING OUT OF THESE TERMS AND CONDITIONS OR THE USE OF THE EVMS PROVIDED HEREUNDER, REGARDLESS OF WHETHER TI HAS BEEN ADVISED OF THE POSSIBILITY OF SUCH DAMAGES. EXCLUDED DAMAGES INCLUDE, BUT ARE NOT LIMITED TO, COST OF REMOVAL OR REINSTALLATION, ANCILLARY COSTS TO THE PROCUREMENT OF SUBSTITUTE GOODS OR SERVICES, RETESTING, OUTSIDE COMPUTER TIME, LABOR COSTS, LOSS OF GOODWILL, LOSS OF PROFITS, LOSS OF SAVINGS, LOSS OF USE, LOSS OF DATA, OR BUSINESS INTERRUPTION. NO CLAIM, SUIT OR ACTION SHALL BE BROUGHT AGAINST TI MORE THAN ONE YEAR AFTER THE RELATED CAUSE OF ACTION HAS OCCURRED.
- 8.2 *Specific Limitations.* IN NO EVENT SHALL TI'S AGGREGATE LIABILITY FROM ANY WARRANTY OR OTHER OBLIGATION ARISING OUT OF OR IN CONNECTION WITH THESE TERMS AND CONDITIONS, OR ANY USE OF ANY TI EVM PROVIDED HEREUNDER, EXCEED THE TOTAL AMOUNT PAID TO TI FOR THE PARTICULAR UNITS SOLD UNDER THESE TERMS AND CONDITIONS WITH RESPECT TO WHICH LOSSES OR DAMAGES ARE CLAIMED. THE EXISTENCE OF MORE THAN ONE CLAIM AGAINST THE PARTICULAR UNITS SOLD TO USER UNDER THESE TERMS AND CONDITIONS SHALL NOT ENLARGE OR EXTEND THIS LIMIT.
9. *Return Policy.* Except as otherwise provided, TI does not offer any refunds, returns, or exchanges. Furthermore, no return of EVM(s) will be accepted if the package has been opened and no return of the EVM(s) will be accepted if they are damaged or otherwise not in a resalable condition. If User feels it has been incorrectly charged for the EVM(s) it ordered or that delivery violates the applicable order, User should contact TI. All refunds will be made in full within thirty (30) working days from the return of the components(s), excluding any postage or packaging costs.
10. *Governing Law:* These terms and conditions shall be governed by and interpreted in accordance with the laws of the State of Texas, without reference to conflict-of-laws principles. User agrees that non-exclusive jurisdiction for any dispute arising out of or relating to these terms and conditions lies within courts located in the State of Texas and consents to venue in Dallas County, Texas. Notwithstanding the foregoing, any judgment may be enforced in any United States or foreign court, and TI may seek injunctive relief in any United States or foreign court.

Mailing Address: Texas Instruments, Post Office Box 655303, Dallas, Texas 75265
Copyright © 2015, Texas Instruments Incorporated

IMPORTANT NOTICE

Texas Instruments Incorporated and its subsidiaries (TI) reserve the right to make corrections, enhancements, improvements and other changes to its semiconductor products and services per JESD46, latest issue, and to discontinue any product or service per JESD48, latest issue. Buyers should obtain the latest relevant information before placing orders and should verify that such information is current and complete. All semiconductor products (also referred to herein as "components") are sold subject to TI's terms and conditions of sale supplied at the time of order acknowledgment.

TI warrants performance of its components to the specifications applicable at the time of sale, in accordance with the warranty in TI's terms and conditions of sale of semiconductor products. Testing and other quality control techniques are used to the extent TI deems necessary to support this warranty. Except where mandated by applicable law, testing of all parameters of each component is not necessarily performed.

TI assumes no liability for applications assistance or the design of Buyers' products. Buyers are responsible for their products and applications using TI components. To minimize the risks associated with Buyers' products and applications, Buyers should provide adequate design and operating safeguards.

TI does not warrant or represent that any license, either express or implied, is granted under any patent right, copyright, mask work right, or other intellectual property right relating to any combination, machine, or process in which TI components or services are used. Information published by TI regarding third-party products or services does not constitute a license to use such products or services or a warranty or endorsement thereof. Use of such information may require a license from a third party under the patents or other intellectual property of the third party, or a license from TI under the patents or other intellectual property of TI.

Reproduction of significant portions of TI information in TI data books or data sheets is permissible only if reproduction is without alteration and is accompanied by all associated warranties, conditions, limitations, and notices. TI is not responsible or liable for such altered documentation. Information of third parties may be subject to additional restrictions.

Resale of TI components or services with statements different from or beyond the parameters stated by TI for that component or service voids all express and any implied warranties for the associated TI component or service and is an unfair and deceptive business practice. TI is not responsible or liable for any such statements.

Buyer acknowledges and agrees that it is solely responsible for compliance with all legal, regulatory and safety-related requirements concerning its products, and any use of TI components in its applications, notwithstanding any applications-related information or support that may be provided by TI. Buyer represents and agrees that it has all the necessary expertise to create and implement safeguards which anticipate dangerous consequences of failures, monitor failures and their consequences, lessen the likelihood of failures that might cause harm and take appropriate remedial actions. Buyer will fully indemnify TI and its representatives against any damages arising out of the use of any TI components in safety-critical applications.

In some cases, TI components may be promoted specifically to facilitate safety-related applications. With such components, TI's goal is to help enable customers to design and create their own end-product solutions that meet applicable functional safety standards and requirements. Nonetheless, such components are subject to these terms.

No TI components are authorized for use in FDA Class III (or similar life-critical medical equipment) unless authorized officers of the parties have executed a special agreement specifically governing such use.

Only those TI components which TI has specifically designated as military grade or "enhanced plastic" are designed and intended for use in military/aerospace applications or environments. Buyer acknowledges and agrees that any military or aerospace use of TI components which have **not** been so designated is solely at the Buyer's risk, and that Buyer is solely responsible for compliance with all legal and regulatory requirements in connection with such use.

TI has specifically designated certain components as meeting ISO/TS16949 requirements, mainly for automotive use. In any case of use of non-designated products, TI will not be responsible for any failure to meet ISO/TS16949.

Products

Audio	www.ti.com/audio
Amplifiers	amplifier.ti.com
Data Converters	dataconverter.ti.com
DLP® Products	www.dlp.com
DSP	dsp.ti.com
Clocks and Timers	www.ti.com/clocks
Interface	interface.ti.com
Logic	logic.ti.com
Power Mgmt	power.ti.com
Microcontrollers	microcontroller.ti.com
RFID	www.ti-rfid.com
OMAP Applications Processors	www.ti.com/omap
Wireless Connectivity	www.ti.com/wirelessconnectivity

Applications

Automotive and Transportation	www.ti.com/automotive
Communications and Telecom	www.ti.com/communications
Computers and Peripherals	www.ti.com/computers
Consumer Electronics	www.ti.com/consumer-apps
Energy and Lighting	www.ti.com/energy
Industrial	www.ti.com/industrial
Medical	www.ti.com/medical
Security	www.ti.com/security
Space, Avionics and Defense	www.ti.com/space-avionics-defense
Video and Imaging	www.ti.com/video

TI E2E Community

e2e.ti.com