

Switching Power Supply Type SPD 240W 3 phases DIN rail mounting



- Universal AC 3 phases input full range
- Installation on DIN rail 7.5 or 15mm
- PFC as standard
- High efficiency up to 90%
- Power ready output
- Parallel connection feature
- Compact dimensions
- UL, cUL listed and TUV/CE

Product Description

The Switching power application where the supplies SPD series are specially designed to be used in all automation and performance are a must.

Ordering Key

SP D 24 240 3

Model _____
 Mounting (D= Din rail) _____
 Output voltage _____
 Output power _____
 Input Type _____

Input type: 3 = three phase (or single phase 400/500VAC³⁾)

Approvals



Output Performances

MODEL NO.	INPUT VOLTAGE	OUTPUT WATTAGE	OUTPUT VOLTAGE	OUTPUT CURRENT	EFF. (min.)	EFF. (typ.)
Single Output Models						
SPD24	3 ϕ 480 VAC	240 WATTS	+24 VDC	10 A	85%	90%
SPD48	3 ϕ 480 VAC	240 WATTS	+48 VDC	5 A	89%	91%

1) When powered with three phases input; with biphasic input value is in the brackets.

2) When S/P switch is set to parallel, it is not possible to trim output voltage.

Output Data

Line regulation	$\pm 1\%$	Rated continuous loading	24V Model	10A @ 24VDC/8.2A @ 28.5VDC
Load regulation			48V Model	5A @ 48VDC/4.2A @ 56VDC
Single mode	$\pm 1\%$	Reverse voltage	12V Model	35VDC
Parallel mode	$\pm 5\%$		24V Model	63VDC
Minimum load	0A	Capacitor load	Vi nom lo nom 24V model	7000 μ F
Turn on time (full resistive load)	1000ms		Voltage rise time	Vi nom lo nom
VI nom, lo nom 12V model with 7000 μ F CAP	1500ms	Vi nom, lo nom 12V model with 7000 μ F CAP		500ms
Transient recovery time	2ms			
Ripple and noise	100mVpp			
Output voltage accuracy	$\pm 1\%$			
Temperature coefficient	$\pm 0.03\%/^{\circ}\text{C}$			
Hold up time Vi	20ms			
Voltage fall time (I _n nom)	150ms max			

Input Data

Rated input voltage	400 - 500VAC		Inrush current time	4 ~ 6 ms	
Voltage range			<small>Vi nom, Io nom</small>		
	AC	340 - 575VAC MAX *	Power dissipation		
	DC	480 - 820VDC MAX *	12V Model	20W	
Input current			24V Model	16W	
<small>(Vi: 400VAC / 500VAC, Io nom)</small>	Typ.	0.65A / 0.55A	Frequency range	47-63Hz	
Rated input current			Leakage current		
<small>(Vi: 340VAC, Io nom)</small>	Max.	0.85A	Input-Output	0.25mA	
Inrush current			Input-FG	3.5mA	
<small>Vi nom, Io nom</small>	Typ.	20A	*not suitable for 600 V applications		
	Max.	25A			

Controls and Protections

Input fuse	2A/600VAC internal/Phase	Over voltage protection	VDC	
Output short circuit	Hiccup mode		Min.	Max.
Power ready output		24V Model	30	33
<small>(only 24V model)</small> on threshold	≥17.6-19.4VDC	48V Model	60	68
Electrical isolation	500VDC	Internal surge voltage protection	Varistor	
Contact rating at 60VDC	0.3A	<small>(IEC 61000-4-5)</small>		
<small>1) Fuse not replaceable by user</small>				

General Data (@ nominal line, full load, 25°C)

Ambient temperature	-40°C to +71°C	MTB (Bellcore issue 6 @ 40°C, GB)	
Derating (>61°C to +71°C)	2.5%/C	24V Model	488000 Hours
Ambient humidity	20 ~ 90% RH	48V Model	519000 Hours
Storage	-25°C to +85°C	Case material	Metal
Protection degree	IP20	Dimensions LxWxD mm(inch)	124 (4.88) x 89 (3.5) x 118.8 (4.68)
Cooling	Free air convection	Weight	1100 g
Pollution degree	2		

Norms and Standards

Vibration resistance	meet IEC 60068-2-6 (Mounting by rail: 10-500Hz, 2G, along X, Y, Z each Axis, 60 min for each Axis)	CQC	GB4943.1-2011, GB9254-2008, GB17625.1-2012
Shock resistance	meet IEC 60068-2-27 (15G, 11ms, 3 Axis, 6 faces, 3 times for each face)	CE	EN 61000-6-3, EN 55022 Class B, EN 61000-3-2, EN 61000-3-3, EN 61000-6-2, EN 55024, EN 61000-4-2 Level 4, EN 61000-4-3 Level 3, EN 61000-4-4 Level 4, EN 61000-4-5 Level 3, L/N-FG Level 4, EN 61000-4-6 Level 3, EN 61000-4-8 Level 4, EN 61000-4-11, ENV 50204 Level 2, EN 61204-3
UL/cUL	UL508 listed, UL60950-1, Recognized, ISA 12.12.01 (Class 1, Division 2, Groups A, B, C and D)		
TUV	EN 60950-1, CB scheme EN 61558-1, EN 61558-2- 17 (meet EN 60204)		

Block Diagram

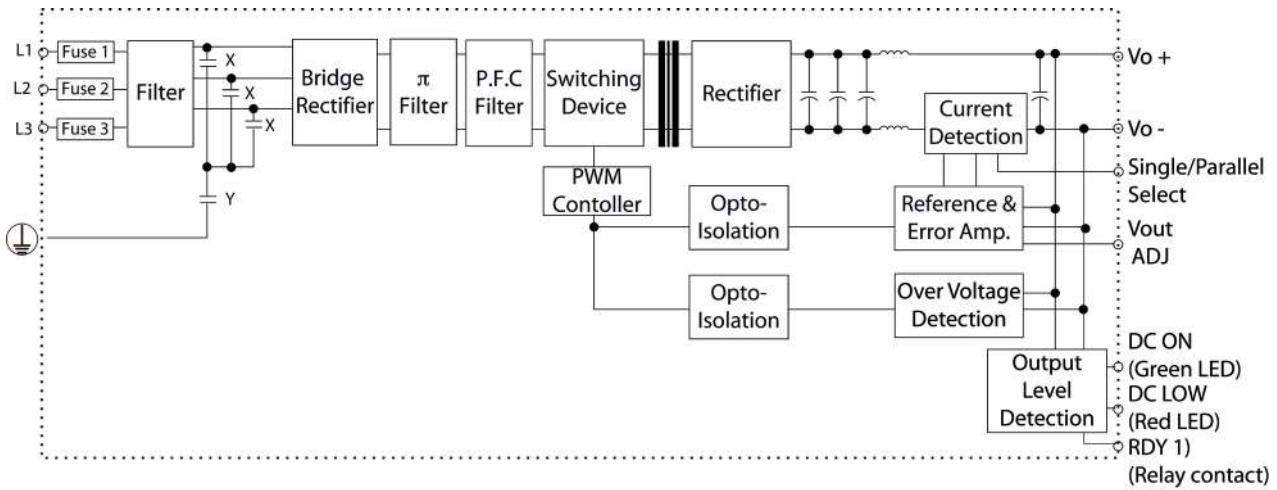

Pin Assignment and Front Controls

Pin No.	Designation	Description
1, 2	V-	Negative output terminal
3, 4	V+	Positive output terminal
5	L3	Input terminals
6	L2	Input terminals
7	L1	Input terminals
8	⊥	Ground this terminal to minimize high-frequency emissions
9	RDY	A normal open relay contact for DC ON level control
10	RDY	(Never connect except 24V model)
	DC ON	Operation indicator LED
	DC LO	DC LOW voltage indicator LED
	Vout ADJ	Trimmer-potentiometer for Vout adjustment
	S/P	Single / Parallel select switch

Derating Diagram

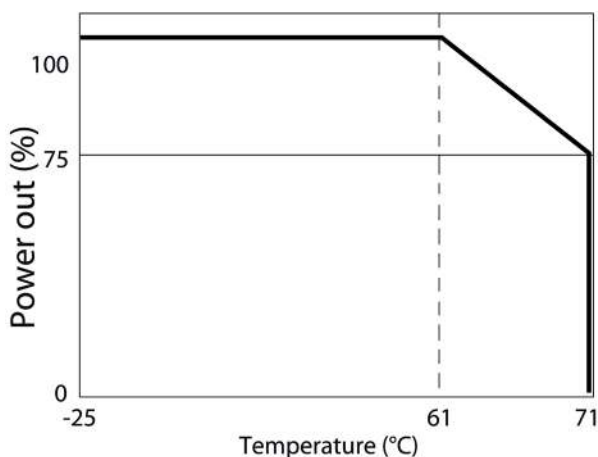

Typ. Efficiency Curve

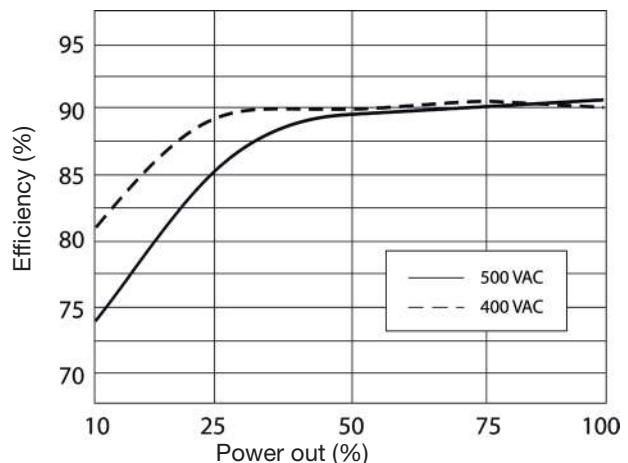

Typ. Current Limited Curve

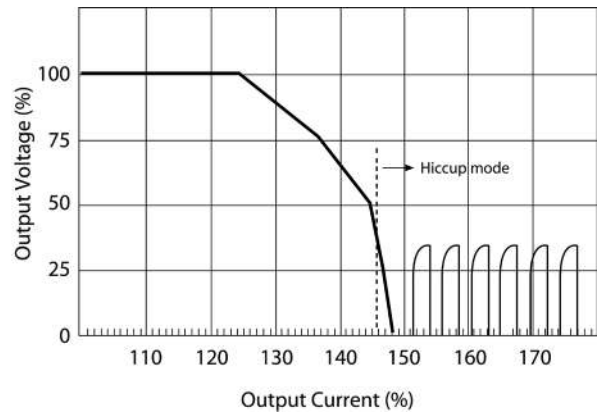
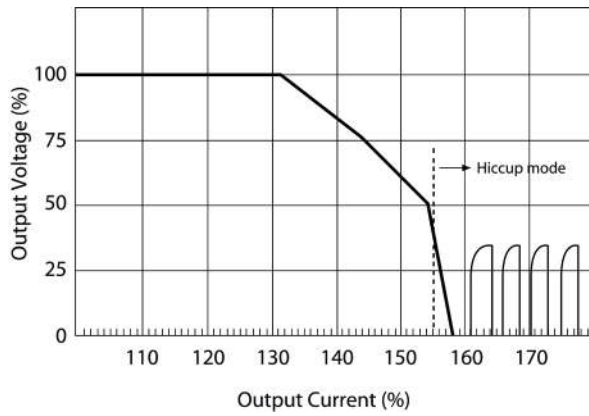

Mechanical Drawings mm (inches)

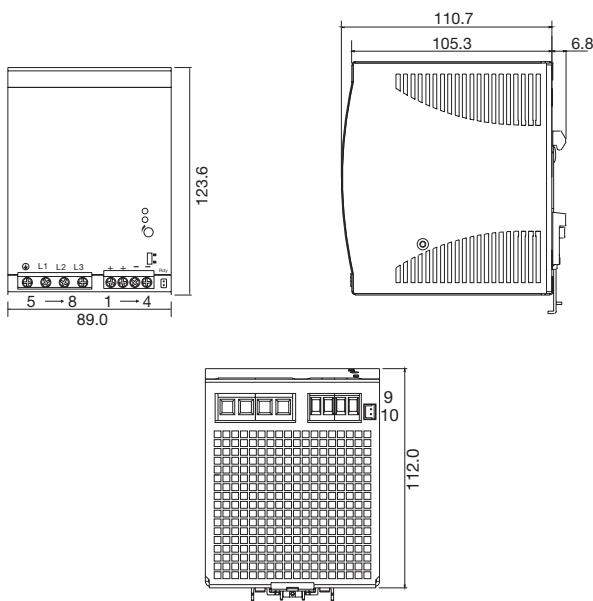

Installation

Ventilation and cooling

Normal convection All sides
 25mm free space for
 cooling is recommended.

Screw connections

10-24AWG flexible or solid
 cable 8mm stripping
 recommend.

Max. torque for screws terminals Input terminal Output terminal

1.008Nm (9.0lb-in)
 0.616Nm (5.5lb-in)