

Double channel high-side driver with CurrentSense analog feedback for automotive applications

Datasheet - production data

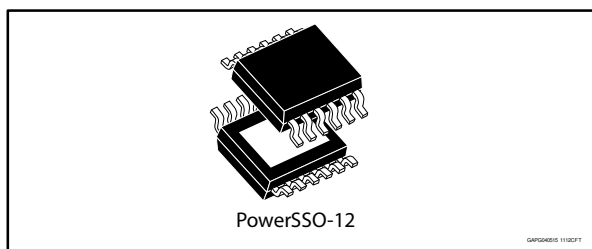

Features

Max transient supply voltage	V_{CC}	40 V
Operating voltage range	V_{CC}	4 V to 28 V
Minimum cranking supply voltage (V_{CC} decreasing)	$V_{USD_Cranking}$	2.85 V
Typ. on-state resistance (per Ch)	R_{ON}	140 m Ω
Current limitation (typ)	I_{LIMH}	12 A
Standby current (max)	I_{STBY}	0.5 μ A

- Automotive qualified
- Extreme low voltage operation for deep cold cranking applications (compliant with LV124, revision 2013)
- General
 - Double channel smart high-side driver with CurrentSense analog feedback
 - Very low standby current
 - Compatible with 3 V and 5 V CMOS outputs
- CurrentSense diagnostic functions
 - Multiplexed analog feedback of: load current with high precision proportional current mirror
 - Overload and short to ground (power limitation) indication
 - Thermal shutdown indication
 - Off-state open-load detection
 - Output short to V_{CC} detection

- Sense enable/ disable
- Protections
 - Undervoltage shutdown
 - Overvoltage clamp
 - Load current limitation
 - Self limiting of fast thermal transients
 - Loss of ground and loss of V_{CC}
 - Reverse battery with external components
 - Electrostatic discharge protection

Applications

- All types of automotive resistive, inductive and capacitive loads
- Specially intended for automotive signal lamps (up to R10W or LED Rear Combinations)

Description

The device is a double channel high-side driver manufactured using ST proprietary VIPower[®] technology and housed in PowerSSO-12 package. The device is designed to drive 12 V automotive grounded loads through a 3 V and 5 V CMOS compatible interface, providing protection and diagnostics.

The device integrates advanced protective functions such as load current limitation, overload active management by power limitation and overtemperature shutdown.

A current sense delivers high precision proportional load current sense in addition to the detection of overload and short circuit to ground, short to V_{CC} and off-state open-load.

A sense enable pin allows off-state diagnosis to be disabled during the module low-power mode as well as external sense resistor sharing among similar devices.

Contents

1	Block diagram and pin description	5
2	Electrical specification.....	7
2.1	Absolute maximum ratings	7
2.2	Thermal data	8
2.3	Main electrical characteristics	8
2.4	Waveforms	18
2.5	Electrical characteristics curves	19
3	Protections.....	23
3.1	Power limitation.....	23
3.2	Thermal shutdown.....	23
3.3	Current limitation	23
3.4	Negative voltage clamp.....	23
4	Application information	24
4.1	GND protection network against reverse battery.....	24
4.1.1	Diode (DGND) in the ground line	25
4.2	Immunity against transient electrical disturbances	25
4.3	MCU I/Os protection.....	26
4.4	Behaviour during engine start transients	26
4.5	CurrentSense - analog current sense	28
4.5.1	Principle of CurrenSense signal generation	29
4.5.2	Short to VCC and OFF-state open-load detection	31
5	Maximum demagnetization energy (VCC = 16 V)	33
6	Package and PCB thermal data	34
6.1	PowerSSO-12 thermal data	34
7	Package information	37
7.1	PowerSSO-12 package information	37
7.2	PowerSSO-12 packing information	38
7.3	PowerSSO-12 marking information.....	40
8	Order codes	41
9	Revision history	42

List of tables

Table 1: Pin functions	5
Table 2: Suggested connections for unused and not connected pins.....	6
Table 3: Absolute maximum ratings	7
Table 4: Thermal data.....	8
Table 5: Electrical characteristics during cranking	8
Table 6: Power section	9
Table 7: Switching.....	9
Table 8: Logic inputs.....	10
Table 9: Protections	11
Table 10: CurrentSense.....	11
Table 11: Truth table.....	17
Table 12: CurrentSense multiplexer addressing	18
Table 13: ISO 7637-2 - electrical transient conduction along supply line.....	26
Table 14: Test parameters, E-11 Start pulses.....	27
Table 15: Cranking operating mode	28
Table 16: CurrentSense pin levels in off-state.....	31
Table 17: PCB properties	34
Table 18: Thermal parameters	36
Table 19: PowerSSO-12 mechanical data.....	38
Table 20: Reel dimensions	38
Table 21: PowerSSO-12 carrier tape dimensions	39
Table 22: Device summary	41
Table 23: Document revision history	42

List of figures

Figure 1: Block diagram.....	5
Figure 2: Configuration diagram (top view).....	6
Figure 3: Current and voltage conventions.....	7
Figure 4: IOOUT/ISENSE versus IOOUT.....	15
Figure 5: Current sense accuracy versus IOOUT.....	15
Figure 6: Switching times and Pulse skew.....	16
Figure 7: CurrentSense timings.....	16
Figure 8: TDSTKON.....	17
Figure 9: Standby mode activation.....	18
Figure 10: Standby state diagram.....	19
Figure 11: OFF-state output current.....	19
Figure 12: Standby current.....	19
Figure 13: IGND(ON) vs. Tcase.....	20
Figure 14: Logic Input high level voltage.....	20
Figure 15: Logic Input low level voltage.....	20
Figure 16: High level logic input current.....	20
Figure 17: Low level logic input current.....	20
Figure 18: Logic Input hysteresis voltage.....	20
Figure 19: Undervoltage shutdown.....	21
Figure 20: On-state resistance vs. Tcase.....	21
Figure 21: On-state resistance vs. Vcc.....	21
Figure 22: Turn-on voltage slope.....	21
Figure 23: Turn-off voltage slope.....	21
Figure 24: Won vs Tcase.....	21
Figure 25: Woff vs Tcase.....	22
Figure 26: ILIMH vs. Tcase.....	22
Figure 27: OFF-state open-load voltage detection threshold.....	22
Figure 28: Vsense clamp vs Tcase.....	22
Figure 29: Vsenseh vs Tcase.....	22
Figure 30: Application diagram.....	24
Figure 31: Simplified internal structure - GND network protection with Schottky diode.....	24
Figure 32: Simplified internal structure - GND network protection with MOSFET.....	25
Figure 33: Cranking profile.....	27
Figure 34: CurrentSense and diagnostic – block diagram.....	28
Figure 35: CurrentSense block diagram.....	29
Figure 36: Analogue HSD – open-load detection in off-state.....	30
Figure 37: Open-load / short to VCC condition.....	31
Figure 38: Maximum turn off current versus inductance.....	33
Figure 39: PowerSSO-12 on two-layers PCB (2s0p to JEDEC JESD 51-5).....	34
Figure 40: PowerSSO-12 on four-layers PCB (2s2p to JEDEC JESD 51-7).....	34
Figure 41: Rthj-amb vs PCB copper area in open box free air condition (one channel on).....	35
Figure 42: PowerSSO-12 thermal impedance junction ambient single pulse (one channel on).....	35
Figure 43: Thermal fitting model of a double-channel HSD in PowerSSO-12.....	36
Figure 44: PowerSSO-12 package dimensions.....	37
Figure 45: PowerSSO-12 reel 13".....	38
Figure 46: PowerSSO-12 carrier tape.....	39
Figure 47: PowerSSO-12 schematic drawing of leader and trailer tape.....	40
Figure 48: PowerSSO-12 marking information.....	40

1 Block diagram and pin description

Figure 1: Block diagram

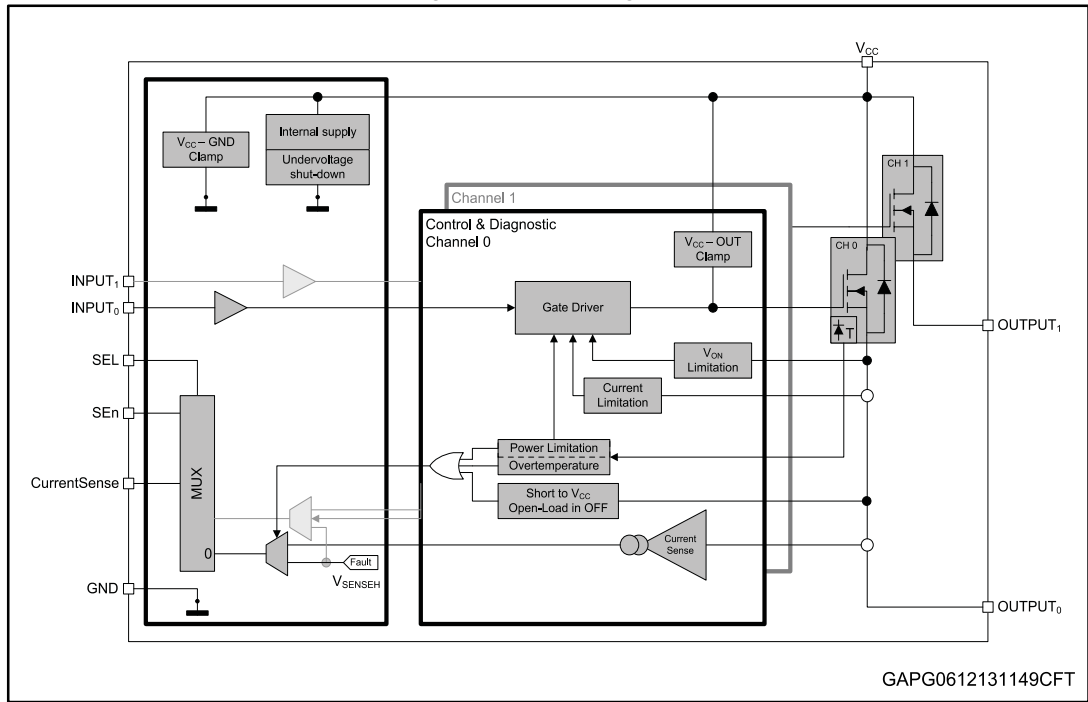

Table 1: Pin functions

Name	Function
V _{CC}	Battery connection.
OUTPUT _{0,1}	Power output.
GND	Ground connection. Must be reverse battery protected by an external diode/resistor network.
INPUT _{0,1}	Voltage controlled input pins with hysteresis, compatible with 3 V and 5 V CMOS outputs. They control output switch state.
CurrentSense	Multiplexed analog sense output pin; it delivers a current proportional to the load current.
SEn	Active high compatible with 3 V and 5 V CMOS outputs pin; it enables the CurrentSense diagnostic pin.
SEL	Active high compatible with 3 V and 5 V CMOS outputs pin; it addresses the CurrentSense multiplexer.

Figure 2: Configuration diagram (top view)

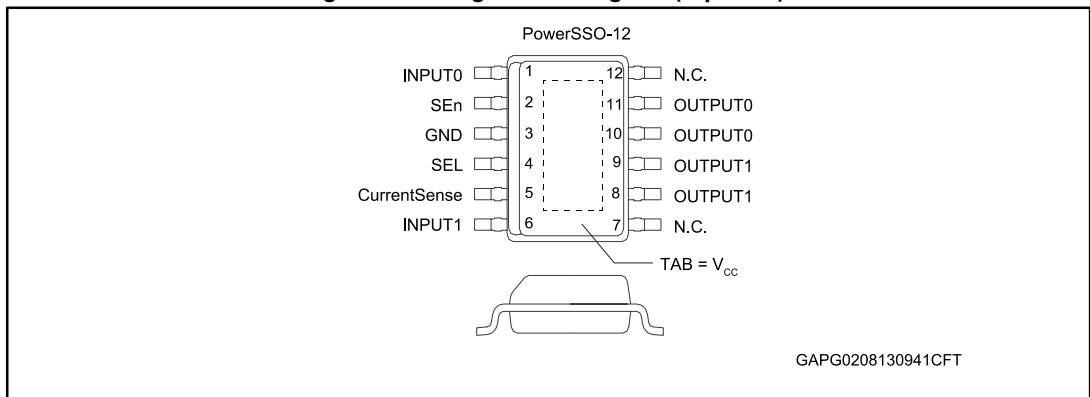

Table 2: Suggested connections for unused and not connected pins

Connection/pin	CurrentSense	N.C.	Output	Input	SE _n , SEL
Floating	Not allowed	X ⁽¹⁾	X	X	X
To ground	Through 1 kΩ resistor	X	Not allowed	Through 15 kΩ resistor	Through 15 kΩ resistor

Notes:

⁽¹⁾X: do not care.

2 Electrical specification

Figure 3: Current and voltage conventions

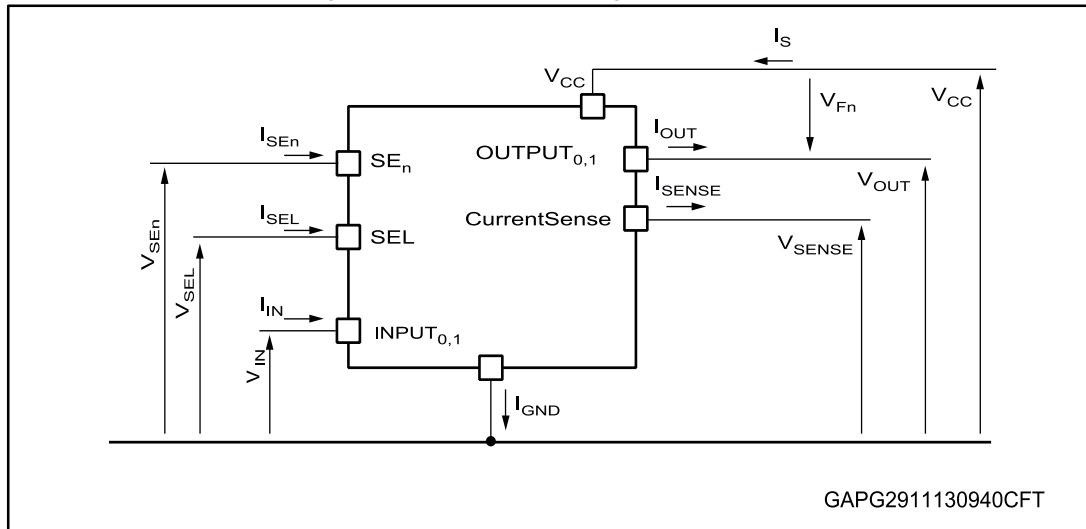

$V_{Fn} = V_{OUTn} - V_{CC}$ during reverse battery condition.

2.1 Absolute maximum ratings

Stressing the device above the rating listed in [Table 3: "Absolute maximum ratings"](#) may cause permanent damage to the device. These are stress ratings only and operation of the device at these or any other conditions above those indicated in the operating sections of this specification is not implied. Exposure to the conditions in table below for extended periods may affect device reliability.

Table 3: Absolute maximum ratings

Symbol	Parameter	Value	Unit
V_{CC}	DC supply voltage	38	V
$-V_{CC}$	Reverse DC supply voltage	0.3	V
V_{CCPK}	Maximum transient supply voltage (ISO 16750-2:2010 Test B clamped to 40 V; $R_L = 4 \Omega$)	40	V
V_{CCJS}	Maximum jump start voltage for single pulse short circuit protection	28	V
$-I_{GND}$	DC reverse ground pin current	200	mA
I_{OUT}	OUTPUT _{0,1} DC output current	Internally limited	A
$-I_{OUT}$	Reverse DC output current	4	
I_{IN}	INPUT _{0,1} DC input current	-1 to 10	mA
I_{SEn}	SEn DC input current		
I_{SEL}	SEL DC input current		
I_{SENSE}	CurrentSense pin DC output current ($V_{GND} = V_{CC}$ and $V_{SENSE} < 0 V$)	10	mA
	CurrentSense pin DC output current in reverse ($V_{CC} < 0V$)	-20	

Symbol	Parameter	Value	Unit
E_{MAX}	Maximum switching energy (single pulse) ($T_{DEMAG} = 0.4 \text{ ms}$; $T_{jstart} = 150 \text{ }^\circ\text{C}$)	10	mJ
V_{ESD}	Electrostatic discharge (JEDEC 22A-114F)		
	• INPUT _{0,1}	4000	V
	• CurrentSense	2000	V
	• SEn, SEL	4000	V
	• OUTPUT _{0,1}	4000	V
	• V _{CC}	4000	V
V_{ESD}	Charge device model (CDM-AEC-Q100-011)	750	V
T_j	Junction operating temperature	-40 to 150	°C
T_{stg}	Storage temperature	-55 to 150	

2.2 Thermal data

Table 4: Thermal data

Symbol	Parameter	Typ. value	Unit
$R_{thj-board}$	Thermal resistance junction-board (JEDEC JESD 51-5 / 51-8) ⁽¹⁾⁽²⁾	7.7	°C/W
$R_{thj-amb}$	Thermal resistance junction-ambient (JEDEC JESD 51-5) ⁽¹⁾⁽³⁾	61	
$R_{thj-amb}$	Thermal resistance junction-ambient (JEDEC JESD 51-7) ⁽¹⁾⁽²⁾	26.5	

Notes:

⁽¹⁾One channel ON.

⁽²⁾Device mounted on four-layers 2s2p PCB.

⁽³⁾Device mounted on two-layers 2s0p PCB with 2 cm² heatsink copper trace.

2.3 Main electrical characteristics

7 V < V_{CC} < 28 V; -40 °C < T_j < 150 °C, unless otherwise specified.

All typical values refer to V_{CC} = 13 V; T_j = 25°C, unless otherwise specified.

Table 5: Electrical characteristics during cranking

Symbol	Parameter	Test conditions	Min.	Typ.	Max.	Unit
$V_{USD_Cranking}$	Minimum cranking supply voltage (V _{CC} decreasing)				2.85	V
R_{ON}	On-state resistance ⁽¹⁾	I _{OUT} = 0.2 A; V _{CC} = 2.85 V; V _{CC} decreasing			1400	mΩ
T_{TSD} ⁽²⁾	Shutdown temperature (V _{CC} decreasing)	V _{CC} = 2.85 V	140			°C

Notes:

⁽¹⁾For each channel.

⁽²⁾Parameter guaranteed by design and characterization; not subject to production test.

Table 6: Power section

Symbol	Parameter	Test conditions	Min.	Typ.	Max.	Unit
V _{CC}	Operating supply voltage		4	13	28	V
V _{USD}	Undervoltage shutdown				2.85	
V _{USDReset}	Undervoltage shutdown reset				5	
V _{USDhyst}	Undervoltage shutdown hysteresis			0.3		
R _{ON}	On-state resistance ⁽¹⁾	I _{OUT} = 1 A; T _j = 25 °C		140		mΩ
		I _{OUT} = 1 A; T _j = 150 °C			280	
		I _{OUT} = 1 A; V _{CC} = 4 V; T _j = 25 °C			210	
V _{clamp}	Clamp voltage	I _S = 20 mA; T _j = -40 °C	38			V
		I _S = 20 mA; 25°C < T _j < 150°C	41	46	52	
I _{STBY}	Supply current in standby at V _{CC} = 13 V ⁽²⁾	V _{CC} = 13 V; V _{IN} = V _{OUT} = V _{SEn} = 0 V; V _{SEL} = 0 V; T _j = 25 °C			0.5	μA
		V _{CC} = 13 V; V _{IN} = V _{OUT} = V _{SEn} = 0 V; V _{SEL} = 0 V; T _j = 85 °C ⁽³⁾			0.5	μA
		V _{CC} = 13 V; V _{IN} = V _{OUT} = V _{SEn} = 0 V; V _{SEL} = 0 V; T _j = 125 °C			3	μA
t _{d_STBY}	Standby mode blanking time	V _{CC} = 13 V; V _{IN} = V _{OUT} = V _{SEL} = 0 V; V _{SEn} = 5 V to 0 V	60	300	550	μA
I _{S(ON)}	Supply current	V _{CC} = 13 V; V _{SEn} = V _{SEL} = 0 V; V _{IN0} = 5 V; V _{IN1} = 5 V; I _{OUT0} = 0 A; I _{OUT1} = 0 A		5	8	mA
I _{GND(ON)}	Control stage current consumption in ON state. All channels active.	V _{CC} = 13 V; V _{SEn} = 5 V; V _{SEL} = 0 V; V _{IN0} = 5 V; V _{IN1} = 5 V; I _{OUT0} = 1 A; I _{OUT1} = 1 A			12	mA
I _{L(off)}	Off-state output current at V _{CC} = 13 V ⁽¹⁾	V _{IN} = V _{OUT} = 0 V; V _{CC} = 13 V; T _j = 25 °C	0	0.01	0.5	μA
		V _{IN} = V _{OUT} = 0 V; V _{CC} = 13 V; T _j = 125 °C	0		3	
V _F	Output - V _{CC} diode voltage ⁽¹⁾	I _{OUT} = -1 A; T _j = 150 °C			0.7	V

Notes:

(1)For each channel.

(2)PowerMOS leakage included.

(3)Parameter specified by design; not subject to production test.

Table 7: Switching

V _{CC} = 13 V; -40°C < T _j < 150°C, unless otherwise specified						
Symbol	Parameter	Test conditions	Min.	Typ.	Max.	Unit
t _{d(on)} ⁽¹⁾	Turn-on delay time at T _j = 25°C	R _L = 13 Ω	10	70	120	μs
t _{d(off)} ⁽¹⁾	Turn-off delay time at T _j = 25°C		10	40	100	
(dV _{OUT} /dt) _{on} ⁽¹⁾	Turn-on voltage slope at T _j = 25°C	R _L = 13 Ω	0.1	0.27	0.7	V/μs
(dV _{OUT} /dt) _{off} ⁽¹⁾	Turn-off voltage slope at T _j = 25°C		0.1	0.35	0.7	

V _{CC} = 13 V; -40°C < T _J < 150°C, unless otherwise specified						
Symbol	Parameter	Test conditions	Min.	Typ.	Max.	Unit
W _{ON}	Switching energy losses at turn-on (t _{won})	R _L = 13 Ω	—	0.15	0.18 ⁽²⁾	mJ
W _{OFF}	Switching energy losses at turn-off (t _{woff})	R _L = 13 Ω	—	0.1	0.18 ⁽²⁾	mJ
t _{SKEW} ⁽¹⁾	Differential pulse skew (t _{PHL} - t _{PLH})	R _L = 13 Ω	-100	-50	0	μs

Notes:

⁽¹⁾See *Figure 6: "Switching times and Pulse skew"*

⁽²⁾Parameter guaranteed by design and characterization; not subject to production test.

Table 8: Logic inputs

7 V < V _{CC} < 28 V; -40°C < T _J < 150°C						
Symbol	Parameter	Test conditions	Min.	Typ.	Max.	Unit
INPUT_{0,1} characteristics						
V _{IL}	Input low level voltage				0.9	V
I _{IL}	Low level input current	V _{IN} = 0.9 V	1			μA
V _{IH}	Input high level voltage		2.1			V
I _{IH}	High level input current	V _{IN} = 2.1 V			10	μA
V _{I(hyst)}	Input hysteresis voltage		0.2			V
V _{ICL}	Input clamp voltage	I _{IN} = 1 mA	5.3		7.2	V
		I _{IN} = -1 mA		-0.7		
SEL characteristics (7 V < V_{CC} < 18 V)						
V _{SELL}	Input low level voltage				0.9	V
I _{SELL}	Low level input current	V _{IN} = 0.9 V	1			μA
V _{SELH}	Input high level voltage		2.1			V
I _{SELH}	High level input current	V _{IN} = 2.1 V			10	μA
V _{SEL(hyst)}	Input hysteresis voltage		0.2			V
V _{SELCL}	Input clamp voltage	I _{IN} = 1 mA	5.3		7.2	V
		I _{IN} = -1 mA		-0.7		
SEn characteristics (7 V < V_{CC} < 18 V)						
V _{SEnL}	Input low level voltage				0.9	V
I _{SEnL}	Low level input current	V _{IN} = 0.9 V	1			μA
V _{SEnH}	Input high level voltage		2.1			V
I _{SEnH}	High level input current	V _{IN} = 2.1 V			10	μA
V _{SEn(hyst)}	Input hysteresis voltage		0.2			V
V _{SEnCL}	Input clamp voltage	I _{IN} = 1 mA	5.3		7.2	V
		I _{IN} = -1 mA		-0.7		

Table 9: Protections

7 V < V _{CC} < 18 V; -40°C < T _j < 150°C						
Symbol	Parameter	Test conditions	Min.	Typ.	Max.	Unit
I _{LIMH}	DC short circuit current	V _{CC} = 13 V	8	12	16	A
		4 V < V _{CC} < 18 V ⁽¹⁾			16	
I _{LIML}	Short circuit current during thermal cycling	V _{CC} = 13 V; T _R < T _j < T _{TSD}		4		
T _{TSD}	Shutdown temperature		150	175	200	°C
T _R	Reset temperature ⁽¹⁾		T _{RS} + 1	T _{RS} + 7		
T _{RS}	Thermal reset of fault diagnostic indication	V _{SEn} = 5 V	135			
T _{HYST}	Thermal hysteresis (T _{TSD} - T _R) ⁽¹⁾			7		
ΔT _{J,SD}	Dynamic temperature	T _j = -40 °C; V _{CC} = 13 V		60		K
V _{DEMAG}	Turn-off output voltage clamp	I _{OUT} = 1 A; L = 6 mH; T _j = -40 °C	V _{CC} - 38			V
		I _{OUT} = 1 A; L = 6 mH; T _j = 25 °C to +150 °C	V _{CC} - 41	V _{CC} - 46	V _{CC} - 52	
V _{ON}	Output voltage drop limitation	I _{OUT} = 0.07 A		20		mV

Notes:

⁽¹⁾Parameter guaranteed by design and characterization; not subject to production test.

Table 10: CurrentSense

7 V < V _{CC} < 18 V; -40°C < T _j < 150°C						
Symbol	Parameter	Test conditions	Min.	Typ.	Max.	Unit
V _{SENSE_CL}	CurrentSense clamp voltage	V _{SEn} = 0 V; I _{SENSE} = 1 mA	-17		-12	V
		V _{SEn} = 0 V; I _{SENSE} = -1 mA		7		V
CurrentSense characteristics						
K _{OL}	I _{OUT} /I _{SENSE}	I _{OUT} = 0.01 A; V _{SENSE} = 0.5 V; V _{SEn} = 5 V	295			
dK _{cal} /K _{cal} ^{(1)/(2)}	Current sense ratio drift at calibration point	I _{OUT} = 0.01 A to 0.025 A; I _{cal} = 17.5 mA; V _{SENSE} = 0.5 V; V _{SEn} = 5 V	-30		30	%
K _{LED}	I _{OUT} /I _{SENSE}	I _{OUT} = 0.025 A; V _{SENSE} = 0.5 V; V _{SEn} = 5 V	330	580	820	
dK _{LED} /K _{LED} ^{(1)/(2)}	Current sense ratio drift	I _{OUT} = 0.025 A; V _{SENSE} = 0.5 V; V _{SEn} = 5 V	-25		25	%
K ₀	I _{OUT} /I _{SENSE}	I _{OUT} = 0.07 A; V _{SENSE} = 0.5 V; V _{SEn} = 5 V	375	550	720	
dK ₀ /K ₀ ^{(1)/(2)}	Current sense ratio drift	I _{OUT} = 0.07 A; V _{SENSE} = 0.5 V; V _{SEn} = 5 V	-20		20	%
K ₁	I _{OUT} /I _{SENSE}	I _{OUT} = 0.15 A; V _{SENSE} = 4 V; V _{SEn} = 5 V	360	500	670	

7 V < V _{CC} < 18 V; -40°C < T _J < 150°C						
Symbol	Parameter	Test conditions	Min.	Typ.	Max.	Unit
dK ₁ /K ₁ ⁽¹⁾⁽²⁾	Current sense ratio drift	I _{OUT} = 0.15 A; V _{SENSE} = 4 V; V _{SEn} = 5 V	-15		15	%
K ₂	I _{OUT} /I _{SENSE}	I _{OUT} = 0.7 A; V _{SENSE} = 4 V; V _{SEn} = 5 V	380	475	570	
dK ₂ /K ₂ ⁽¹⁾⁽²⁾	Current sense ratio drift	I _{OUT} = 0.7 A; V _{SENSE} = 4 V; V _{SEn} = 5 V	-10		10	%
K ₃	I _{OUT} /I _{SENSE}	I _{OUT} = 2 A; V _{SENSE} = 4 V; V _{SEn} = 5 V	430	470	520	
dK ₃ /K ₃ ⁽¹⁾⁽²⁾	Current sense ratio drift	I _{OUT} = 2 A; V _{SENSE} = 4 V; V _{SEn} = 5 V	-5		5	%
I _{SENSE0}	CurrentSense leakage current	CurrentSense disabled: V _{SEn} = 0 V	0		0.5	μA
		CurrentSense disabled: -1 V < V _{SENSE} < 5 V ⁽¹⁾	-0.5		0.5	μA
		CurrentSense enabled: V _{SEn} = 5 V; All channel ON; I _{OUTX} = 0 A; Ch _x diagnostic selected; • E.g. Ch ₀ : V _{IN0} = 5 V; V _{IN1} = 5 V; V _{SEL} = 0 V; I _{OUT0} = 0 A; I _{OUT1} = 1 A	0		2	μA
		CurrentSense enabled: V _{SEn} = 5 V; Ch _x channel OFF; Ch _x diagnostic selected; • E.g. Ch ₀ : V _{IN0} = 0 V; V _{IN1} = 5 V; V _{SEL} = 0 V; I _{OUT1} = 1 A	0		2	μA
V _{OUT_MSD} ⁽¹⁾	Output Voltage for CurrentSense shutdown	V _{SEn} = 5 V; R _{SENSE} = 2.7 kΩ • E.g. Ch ₀ : V _{IN0} = 5 V; V _{SEL} = 0 V; I _{OUT0} = 1 A		5		V
V _{SENSE_SAT}	CurrentSense saturation voltage	V _{CC} = 7 V; R _{SENSE} = 2.7 kΩ; V _{SEn} = 5 V; V _{IN0} = 5 V; V _{SEL} = 0 V; I _{OUT0} = 1 A; T _j = 150°C	5			V
I _{SENSE_SAT} ⁽¹⁾	CS saturation current	V _{CC} = 7 V; V _{SENSE} = 4 V; V _{IN0} = 5 V; V _{SEn} = 5 V; V _{SEL0} = 0 V; V _{SEL1} = 0 V; T _j = 150°C	4			mA



7 V < V _{CC} < 18 V; -40°C < T _j < 150°C						
Symbol	Parameter	Test conditions	Min.	Typ.	Max.	Unit
I _{OUT_SAT} ⁽¹⁾	Output saturation current	V _{CC} = 7 V; V _{SENSE} = 4 V; V _{IN0} = 5 V; V _{SEn} = 5 V; V _{SEL} = 0 V; T _j = 150°C	2.2			A
Off-state diagnostic						
V _{OL}	Off-state open-load voltage detection threshold	V _{SEn} = 5 V; Ch _X OFF; Ch _X diagnostic selected • E.g: Ch ₀ V _{IN0} = 0 V; V _{SEL} = 0 V	2	3	4	V
I _{L(off2)}	Off-state output sink current	V _{IN} = 0 V; V _{OUT} = V _{OL} ; T _j = -40 °C to 125 °C	-100		-15	μA
t _{DSTKON}	Off-state diagnostic delay time from falling edge of INPUT (see Figure 8: "TDSTKON")	V _{SEn} = 5 V; Ch _X ON to OFF transition Ch _X diagnostic selected • E.g: Ch ₀ V _{IN0} = 5 V to 0 V; V _{SEL} = 0 V; I _{OUT0} = 0 A; V _{OUT} = 4 V	100	350	700	μs
t _{D_OL_V}	Settling time for valid OFF-state open load diagnostic indication from rising edge of SEn	V _{IN0} = 0 V; V _{IN1} = 0 V; V _{SEL} = 0 V; V _{OUT0} = 4 V; V _{SEn} = 0 V to 5 V			60	μs
t _{D_VOL}	Off-state diagnostic delay time from rising edge of V _{OUT}	V _{SEn} = 5 V; Ch _X OFF Ch _X diagnostic selected • E.g: Ch ₀ V _{IN0} = 0 V; V _{SEL} = 0 V; V _{OUT} = 0 V to 4 V		5	30	μs
Fault diagnostic feedback (see Table 11: "Truth table")						
V _{SENSEH}	CurrentSense output voltage in fault condition	V _{CC} = 13 V; R _{SENSE} = 1 kΩ • E.g: Ch ₀ in open load V _{IN0} = 0 V; V _{SEn} = 5 V; V _{SEL} = 0 V; I _{OUT0} = 0 A; V _{OUT} = 4 V	5		6.6	V
I _{SENSEH}	CurrentSense output current in fault condition	V _{CC} = 13 V; V _{SENSE} = 5 V	7	20	30	mA
CurrentSense timings (current sense mode - see Figure 7: "CurrentSense timings")⁽³⁾						
t _{DSSENSE1H}	Current sense settling time from rising edge of SEn	V _{IN} = 5 V; V _{SEn} = 0 V to 5 V; R _{SENSE} = 1 kΩ; R _L = 13 Ω			60	μs
t _{DSSENSE1L}	Current sense disable delay time from falling edge of SEn	V _{IN} = 5 V; V _{SEn} = 5 V to 0 V; R _{SENSE} = 1 kΩ; R _L = 13 Ω		5	20	μs

7 V < V _{CC} < 18 V; -40°C < T _j < 150°C						
Symbol	Parameter	Test conditions	Min.	Typ.	Max.	Unit
t _{DSSENSE2H}	Current sense settling time from rising edge of INPUT	V _{IN} = 0 V to 5 V; V _{SEN} = 5 V; R _{SENSE} = 1 kΩ; R _L = 13 Ω		100	250	μs
Δt _{DSSENSE2H}	Current sense settling time from rising edge of I _{OUT} (dynamic response to a step change of I _{OUT})	V _{IN} = 5 V; V _{SEN} = 5 V; R _{SENSE} = 1 kΩ; I _{SENSE} = 90 % of I _{SENSEMAX} ; R _L = 13 Ω			100	μs
t _{DSSENSE2L}	Current sense turn-off delay time from falling edge of INPUT	V _{IN} = 5 V to 0 V; V _{SEN} = 5 V; R _{SENSE} = 1 kΩ; R _L = 13 Ω		50	250	μs
CurrentSense timings (Multiplexer transition times) ⁽³⁾						
t _{D_XtoY}	CurrentSense transition delay from Ch _X to Ch _Y	V _{IN0} = 5 V; V _{IN1} = 5 V; V _{SEN} = 5 V; V _{SEL} = 0 V to 5 V; I _{OUT0} = 0 A; I _{OUT1} = 1 A; R _{SENSE} = 1 kΩ			20	μs
t _{D_CSstoVSENSEH}	CurrentSense transition delay from stable current sense on Ch _X to V _{SENSEH} on Ch _Y	V _{IN0} = 5 V; V _{IN1} = 0 V; V _{SEN} = 5 V; V _{SEL} = 0 V to 5 V; I _{OUT0} = 1 A; V _{OUT1} = 4 V; R _{SENSE} = 1 kΩ			60	μs

Notes:

- (1)Parameter guaranteed by design and characterization; not subject to production test.
(2)All values refer to V_{CC} = 13 V; T_j = 25°C, unless otherwise specified.
(3)Transition delays are measured up to +/- 10% of final conditions.

Figure 4: IO_{UT}/ISENSE versus IO_{UT}

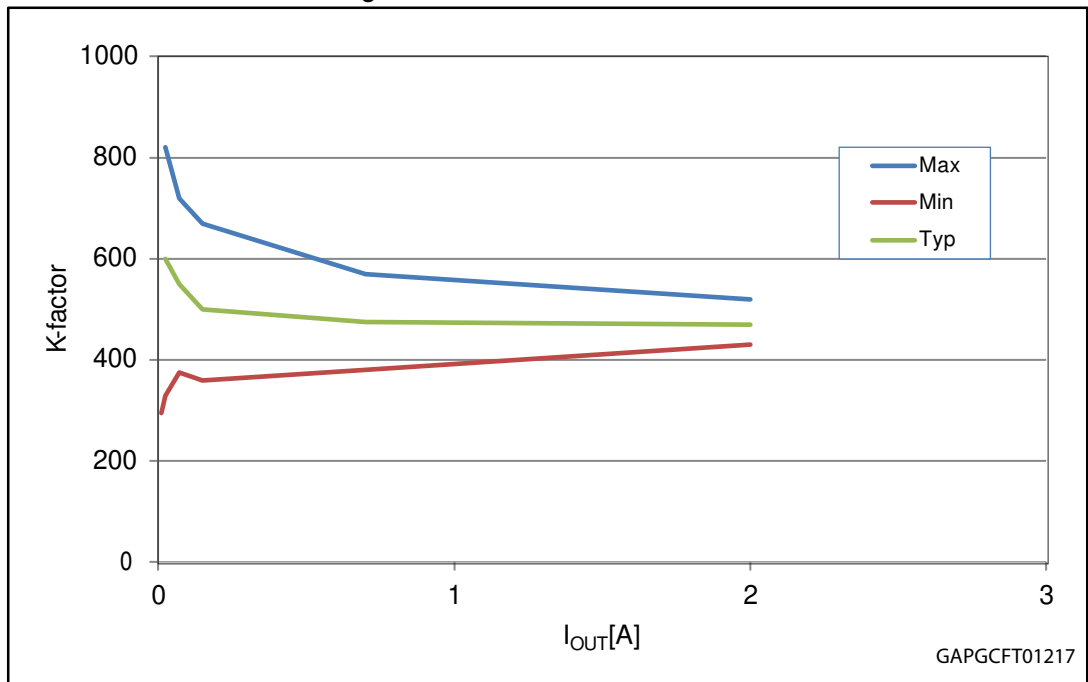

Figure 5: Current sense accuracy versus IO_{UT}

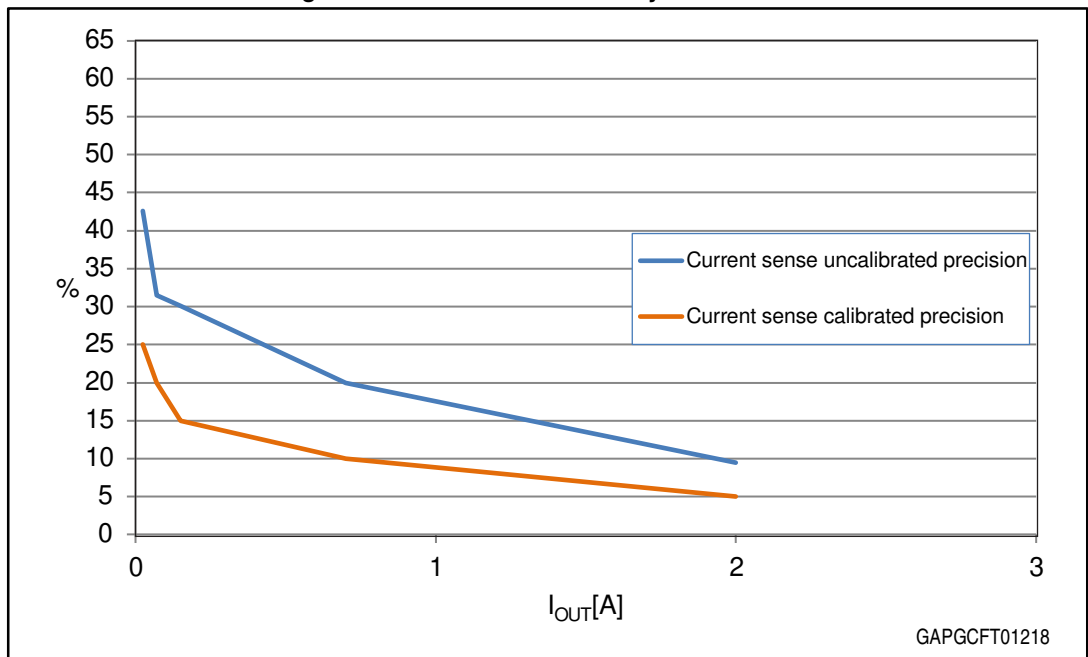

Figure 6: Switching times and Pulse skew

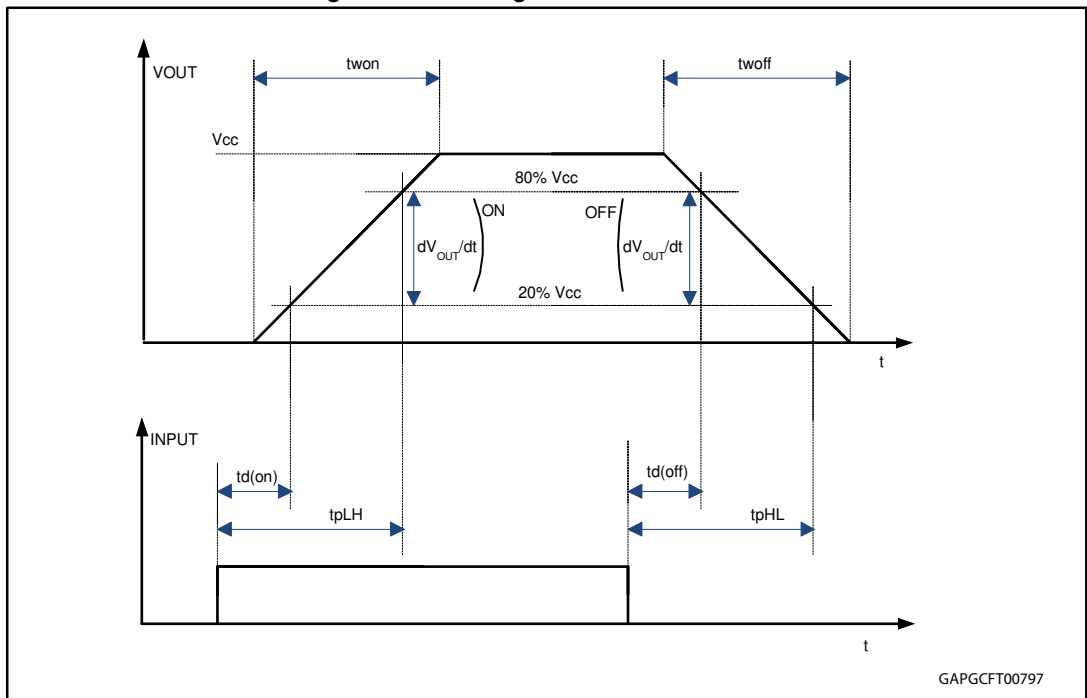

Figure 7: CurrentSense timings

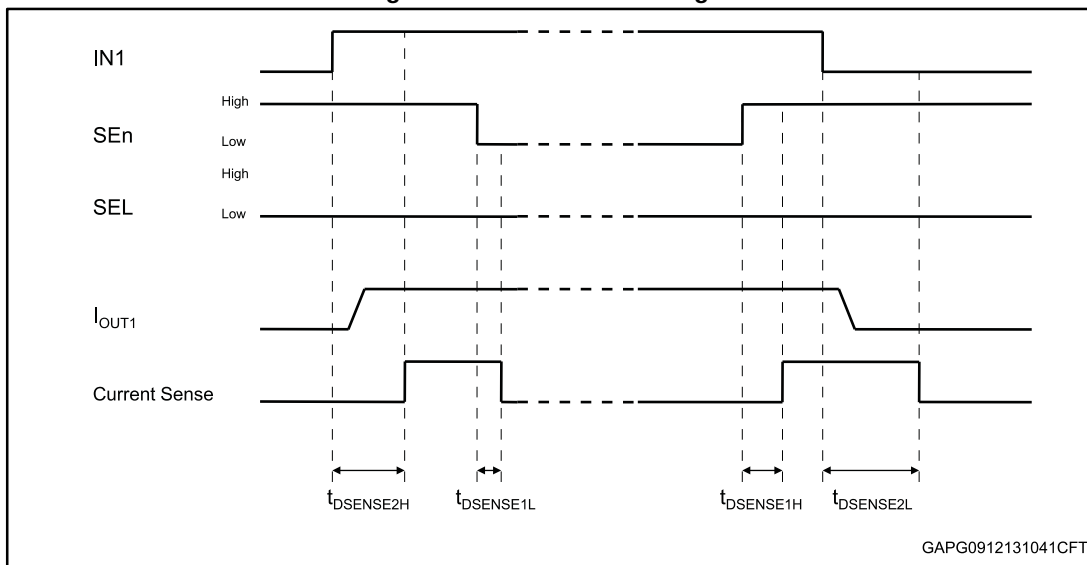

Figure 8: TDSTKON

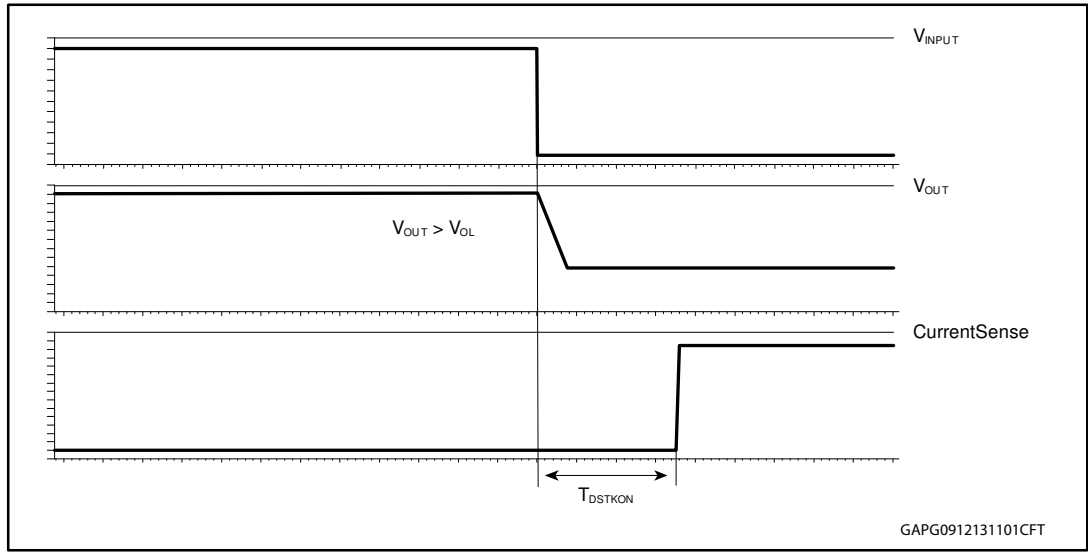

Table 11: Truth table

Mode	Conditions	IN _x	SEn	SEL	OUT _x	CurrentSense	Comments
Standby	All logic inputs low	L	L	L	L	Hi-Z	Low quiescent current consumption
Normal	Nominal load connected; $T_j < 150^\circ\text{C}$	L	See ⁽¹⁾		L	See ⁽¹⁾	
		H			H	See ⁽¹⁾	Outputs configured for auto-restart
		H			H	See ⁽¹⁾	Outputs configured for latch off
Overload	Overload or short to GND causing: $T_j > T_{TSD}$ or $\Delta T_j > \Delta T_{j_SD}$	L	See ⁽¹⁾		L	See ⁽¹⁾	
		H			H	See ⁽¹⁾	Output cycles with temperature hysteresis
		H			L	See ⁽¹⁾	Output latches off
Under-voltage	$V_{CC} < V_{USD}$ (falling)	X	X	X	L L	Hi-Z Hi-Z	Re-start when $V_{CC} > V_{USD} + V_{USDhyst}$ (rising)
Off-state diagnostics	Short to V_{CC}	L	See ⁽¹⁾		H	See ⁽¹⁾	
	Open-load	L			H	See ⁽¹⁾	External pull up
Negative output voltage	Inductive loads turn-off	L	See ⁽¹⁾		$< 0\text{ V}$	See ⁽¹⁾	

Notes:

⁽¹⁾Refer to [Table 12: "CurrentSense multiplexer addressing"](#)

Table 12: CurrentSense multiplexer addressing

SEn	SEL	MUX channel	CurrentSense output			
			Normal mode	Overload	Off-state diag.	Negative output
L	X		Hi-Z			
H	L	Channel 0 diagnostic	$I_{SENSE} = 1/K * I_{OUT0}$	$V_{SENSE} = V_{SENSEH}$	$V_{SENSE} = V_{SENSEH}$	Hi-Z
H	H	Channel 1 diagnostic	$I_{SENSE} = 1/K * I_{OUT1}$	$V_{SENSE} = V_{SENSEH}$	$V_{SENSE} = V_{SENSEH}$	Hi-Z

2.4 Waveforms

Figure 9: Standby mode activation

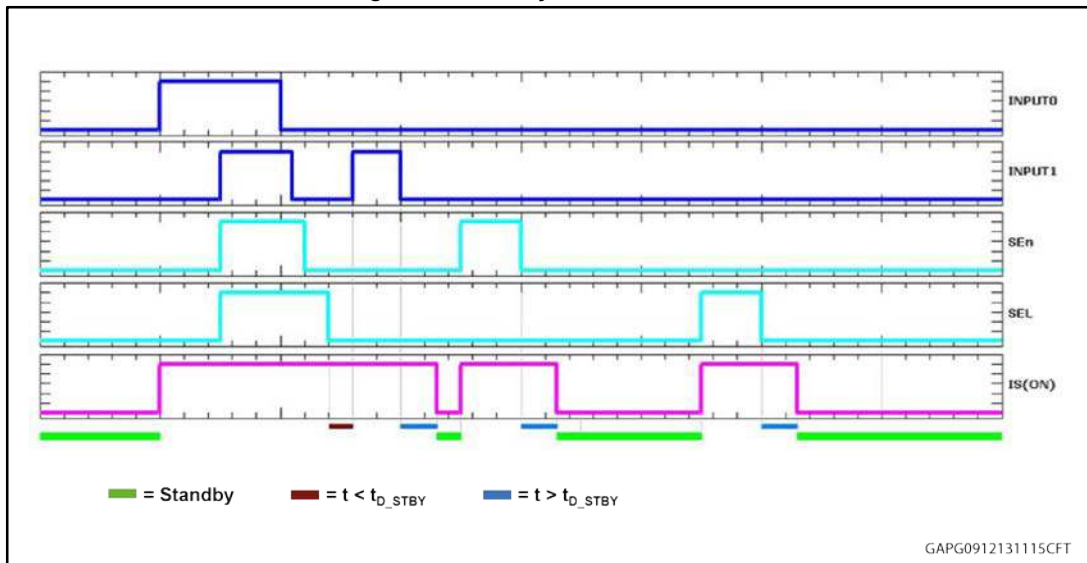
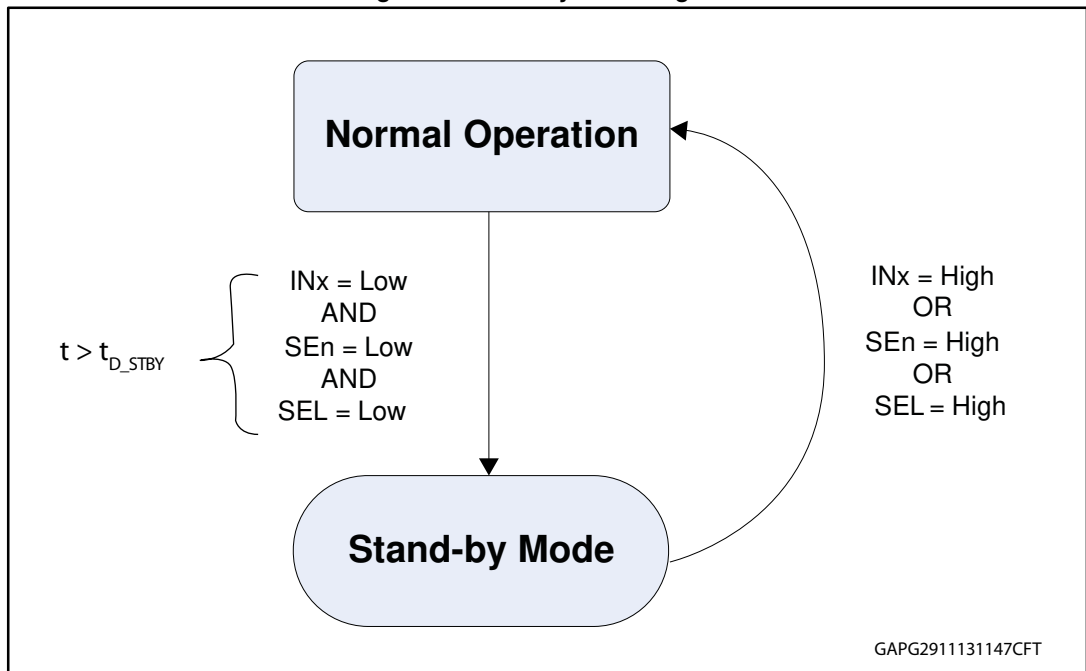
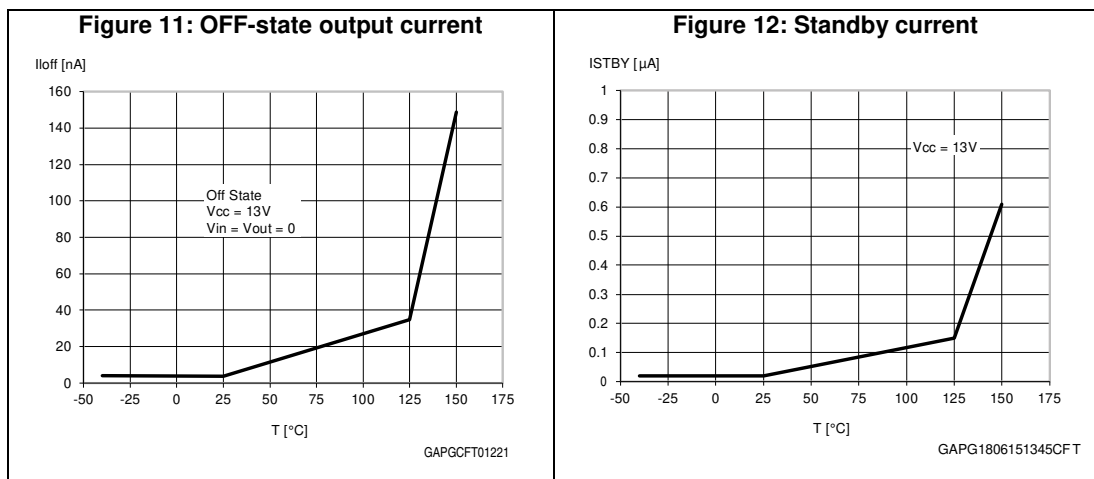

Figure 10: Standby state diagram



2.5 Electrical characteristics curves



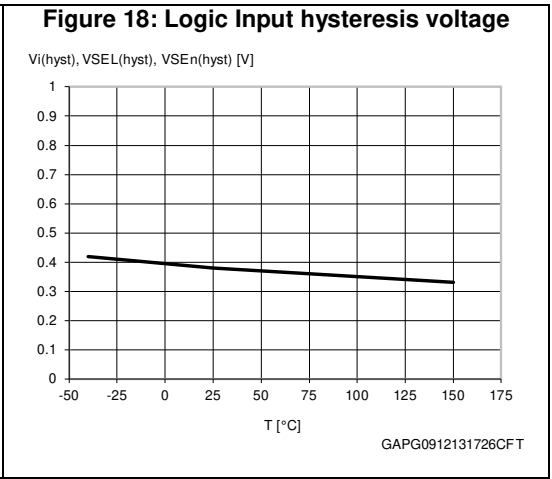
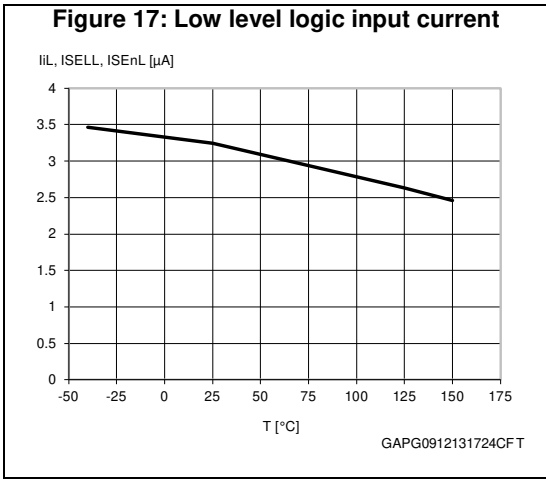
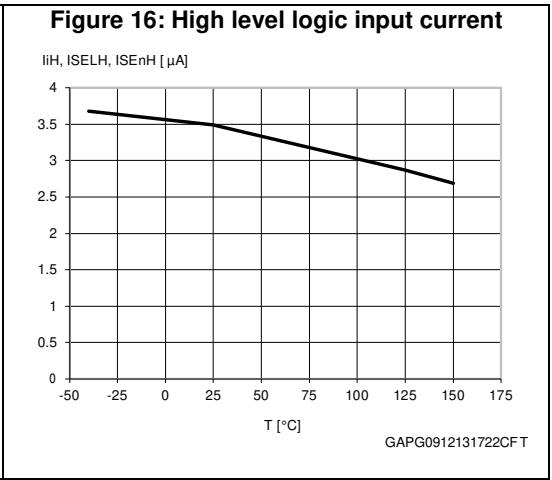
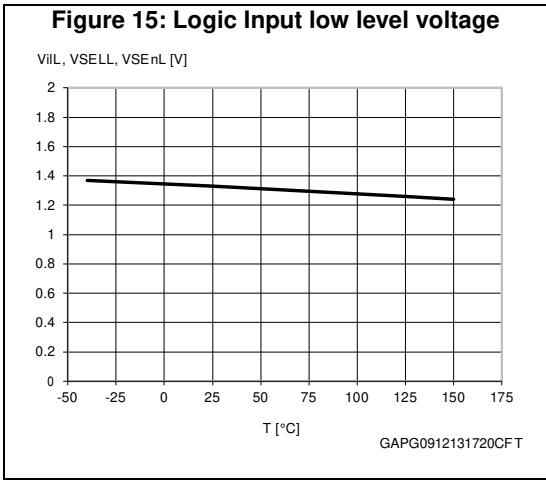
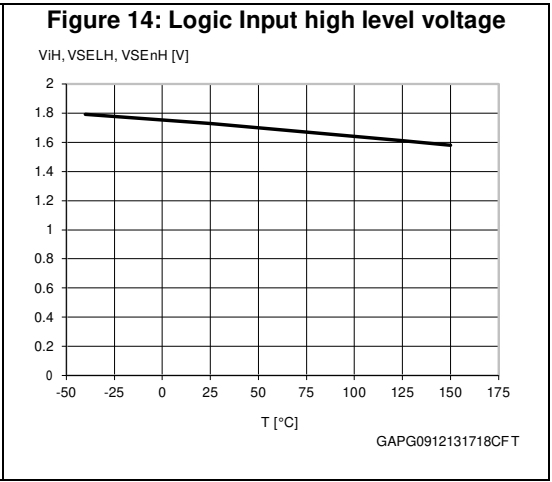
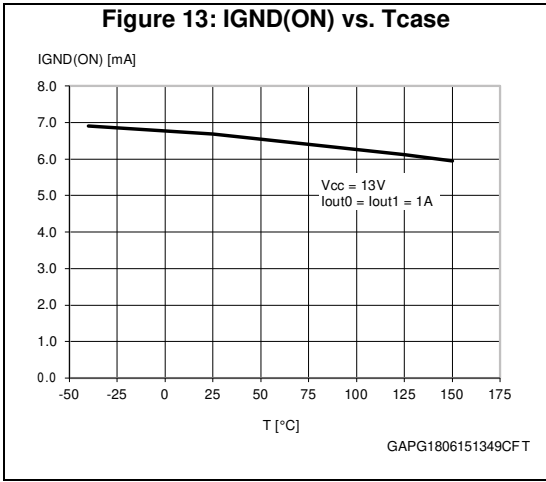

Figure 19: Undervoltage shutdown

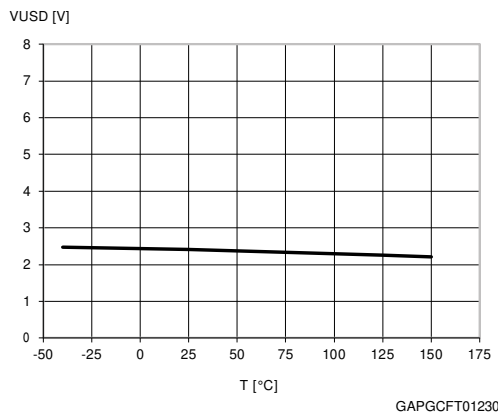

Figure 20: On-state resistance vs. Tcase

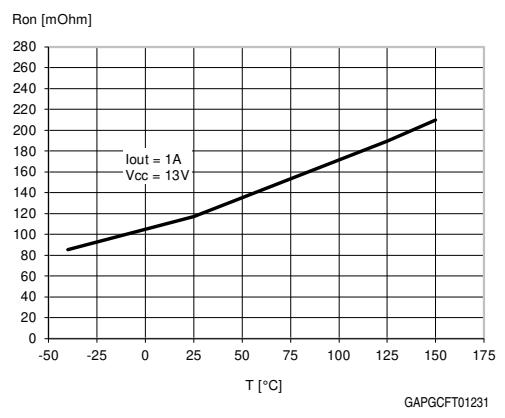

Figure 21: On-state resistance vs. Vcc

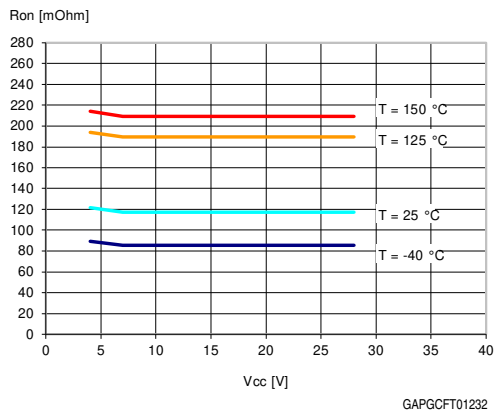

Figure 22: Turn-on voltage slope

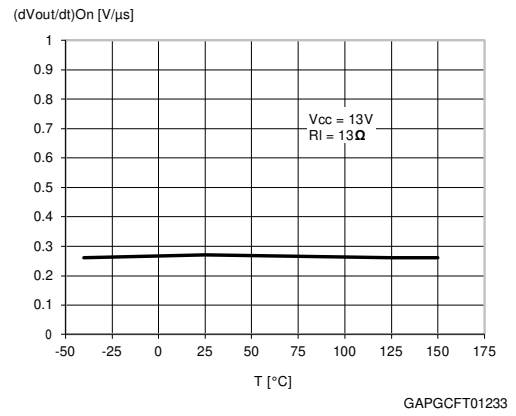

Figure 23: Turn-off voltage slope

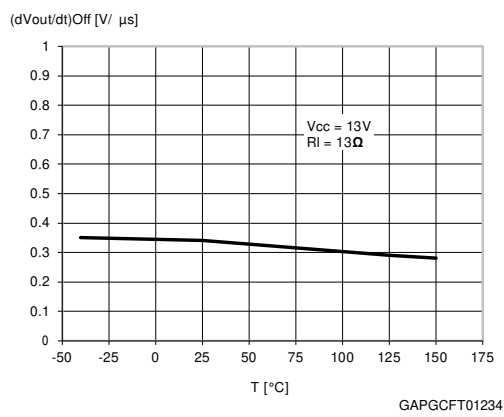
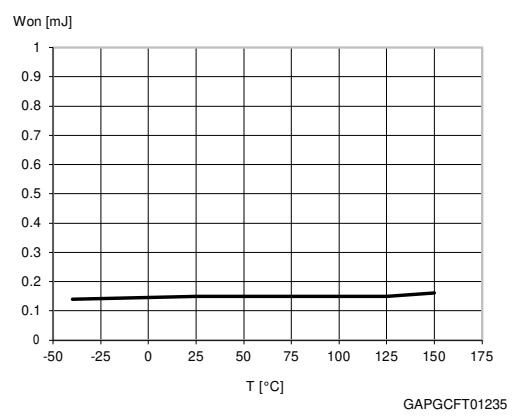
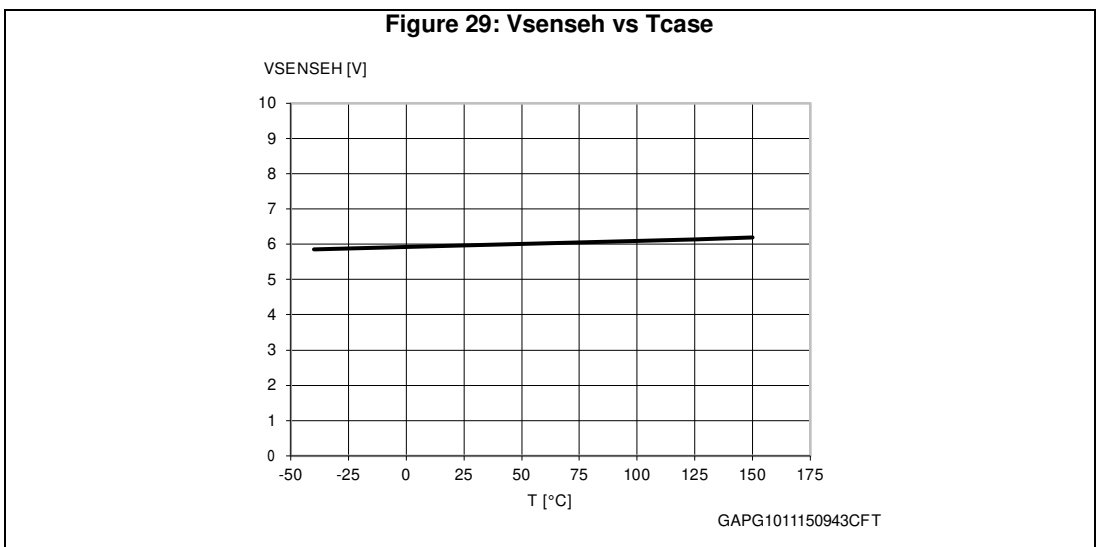
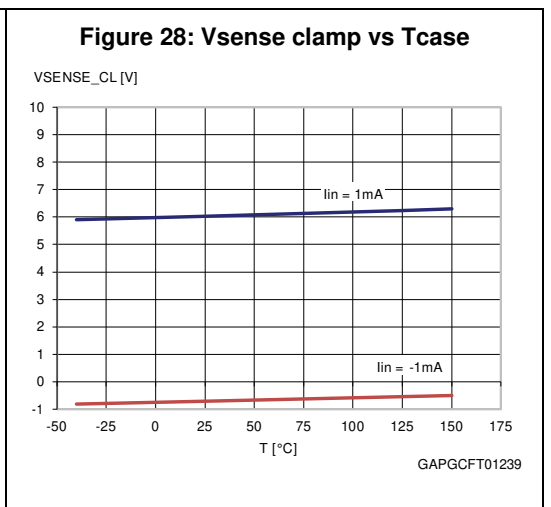
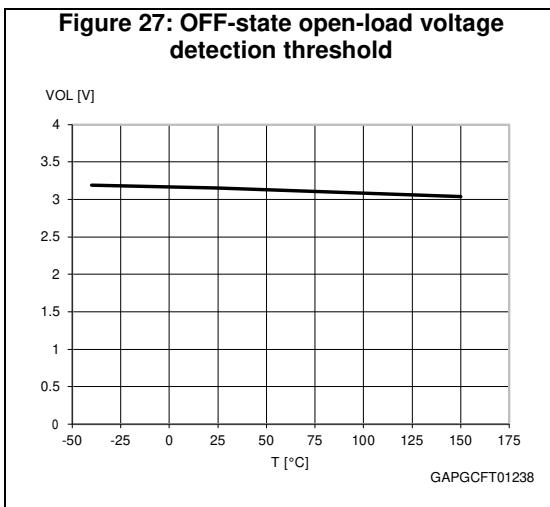
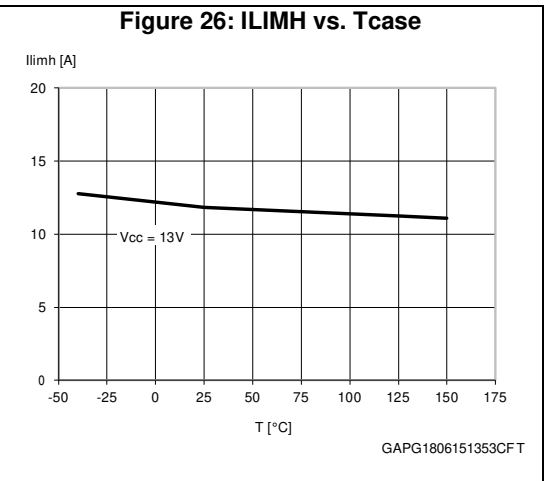
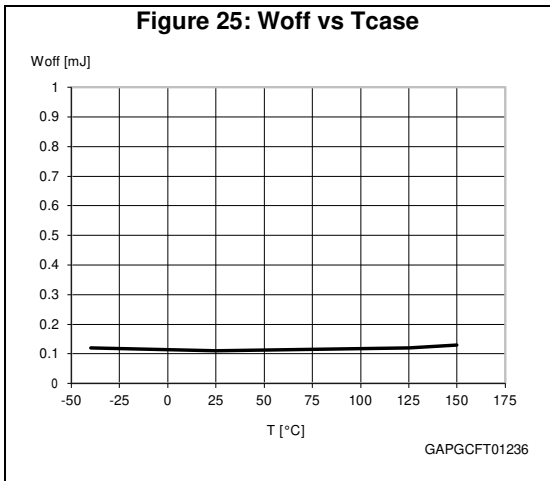

Figure 24: Won vs Tcase





3 Protections

3.1 Power limitation

The basic working principle of this protection consists of an indirect measurement of the junction temperature swing ΔT_j through the direct measurement of the spatial temperature gradient on the device surface in order to automatically shut off the output MOSFET as soon as ΔT_j exceeds the safety level of ΔT_{j_SD} . The output MOSFET switches on and cycles with a thermal hysteresis according to the maximum instantaneous power which can be handled. The protection prevents fast thermal transient effects and, consequently, reduces thermo-mechanical fatigue.

3.2 Thermal shutdown

In case the junction temperature of the device exceeds the maximum allowed threshold (typically 175°C), it automatically switches off and the diagnostic indication is triggered. The device switches on again as soon as its junction temperature drops to T_R .

3.3 Current limitation

The device is equipped with an output current limiter in order to protect the silicon as well as the other components of the system (e.g. bonding wires, wiring harness, connectors, loads, etc.) from excessive current flow. Consequently, in case of short circuit, overload or during load power-up, the output current is clamped to a safety level, I_{LIMH} , by operating the output power MOSFET in the active region.

3.4 Negative voltage clamp

In case the device drives inductive load, the output voltage reaches a negative value during turn off. A negative voltage clamp structure limits the maximum negative voltage to a certain value, V_{DEMAG} , allowing the inductor energy to be dissipated without damaging the device.

4 Application information

Figure 30: Application diagram

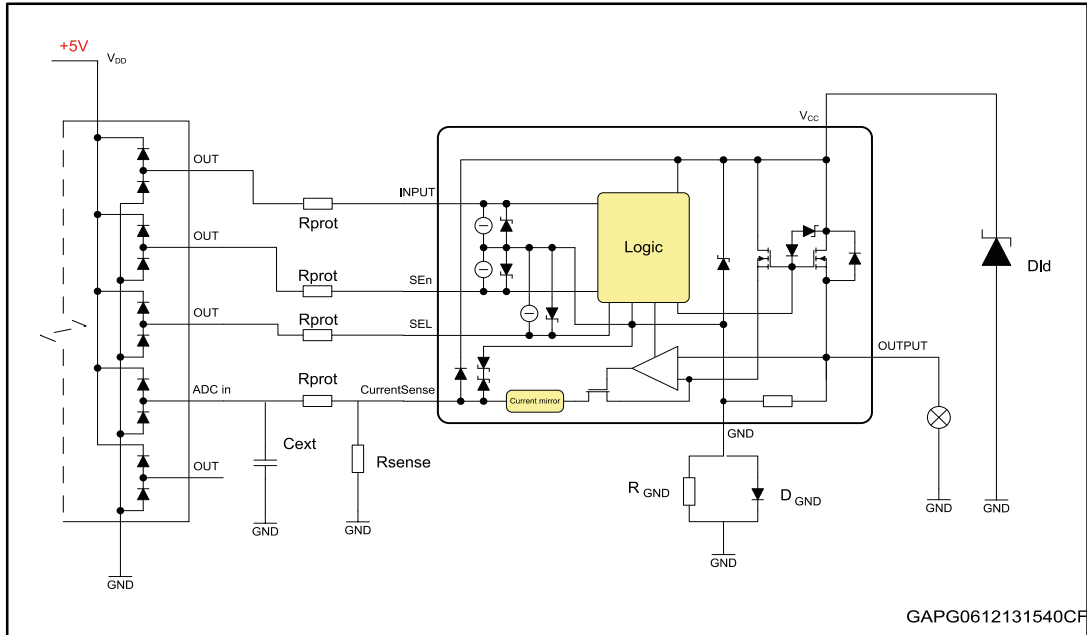

4.1 GND protection network against reverse battery

Figure 31: Simplified internal structure - GND network protection with Schottly diode

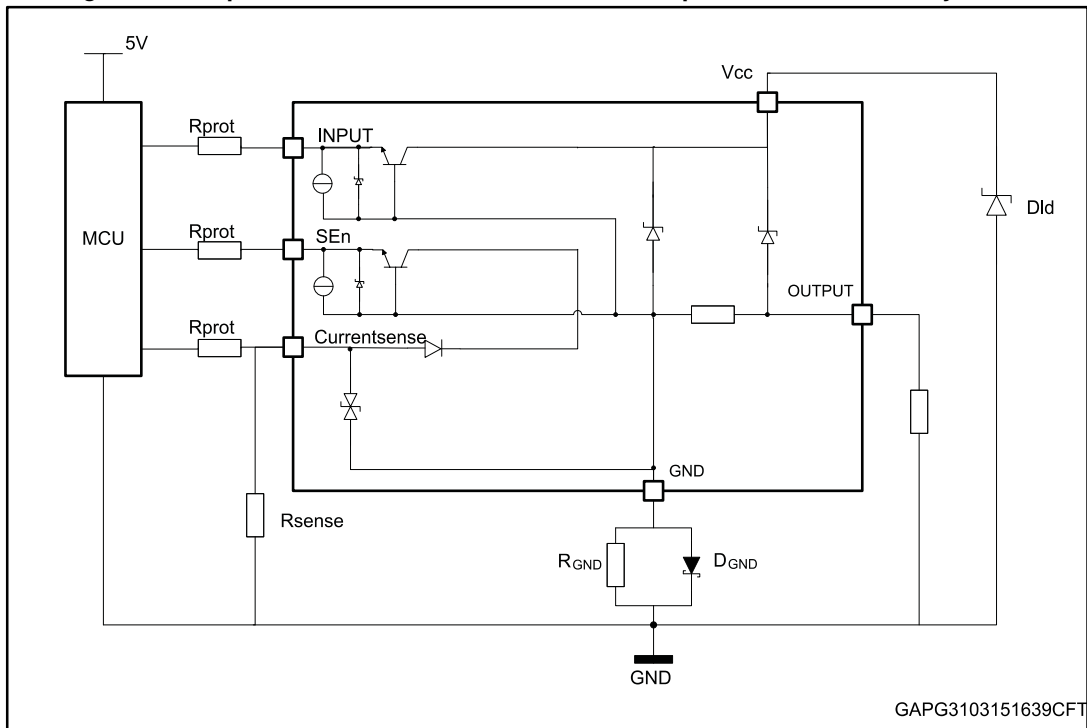
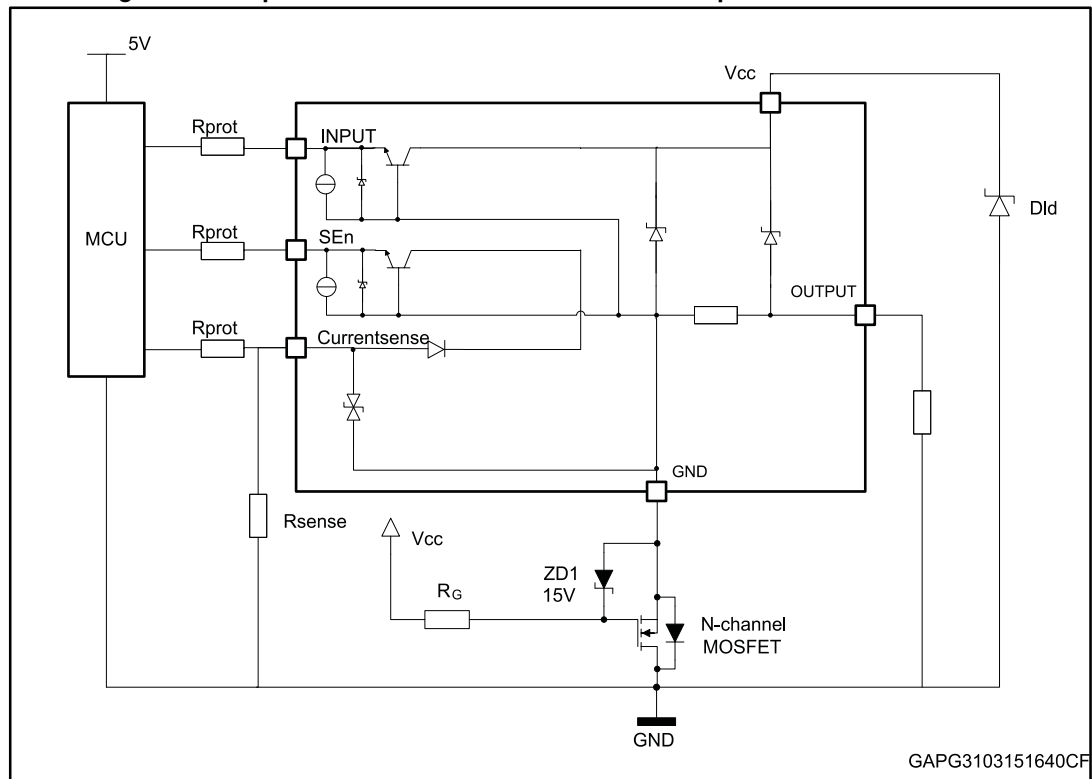

Figure 32: Simplified internal structure - GND network protection with MOSFET



GAPG3103151640CF

4.1.1 Diode (DGND) in the ground line

A resistor (typ. $R_{GND} = 4.7 \text{ k}\Omega$) should be inserted in parallel to D_{GND} if the device drives an inductive load.

This small signal diode can be safely shared amongst several different HSDs. Also in this case, the presence of the ground network produces a shift ($\gg 600 \text{ mV}$) in the input threshold and in the status output values if the microprocessor ground is not common to the device ground. This shift does not vary if more than one HSD shares the same diode/resistor network.

To comply with LV124, E-11 "severe" start pulse, a Schottky diode (see [Figure 31: "Simplified internal structure - GND network protection with Schottky diode"](#)) or N-channel MOSFET (see [Figure 32: "Simplified internal structure - GND network protection with MOSFET"](#)) is recommended in order to ensure a lower ground network shift ($\leq 350 \text{ mV}$).

4.2 Immunity against transient electrical disturbances

The immunity of the device against transient electrical emissions, conducted along the supply lines and injected into the V_{CC} pin, is tested in accordance with ISO7637-2:2011 (E) and ISO 16750-2:2010.

The related function performance status classification is shown in [Table 13: "ISO 7637-2 - electrical transient conduction along supply line"](#).

Test pulses are applied directly to DUT (Device Under Test) both in ON and OFF-state and in accordance to ISO 7637-2:2011(E), chapter 4. The DUT is intended as the present device only, without components and accessed through V_{CC} and GND terminals.

Status II is defined in ISO 7637-1 Function Performance Status Classification (FPSC) as follows: "The function does not perform as designed during the test but returns automatically to normal operation after the test".

Table 13: ISO 7637-2 - electrical transient conduction along supply line

Test Pulse 2011(E)	Test pulse severity level with Status II functional performance status		Minimum number of pulses or test time	Burst cycle / pulse repetition time		Pulse duration and pulse generator internal impedance
	Level	U _S ⁽¹⁾		min	max	
1	III	-112V	500 pulses	0,5 s		2ms, 10Ω
2a	III	+55V	500 pulses	0,2 s	5 s	50μs, 2Ω
3a	IV	-220V	1h	90 ms	100 ms	0.1μs, 50Ω
3b	IV	+150V	1h	90 ms	100 ms	0.1μs, 50Ω
4 ⁽²⁾	IV	-7V	1 pulse			100ms, 0.01Ω
Load dump according to ISO 16750-2:2010						
Test B ⁽³⁾		40V	5 pulse	1 min		400ms, 2Ω

Notes:

⁽¹⁾U_S is the peak amplitude as defined for each test pulse in ISO 7637-2:2011(E), chapter 5.6.

⁽²⁾Test pulse from ISO 7637-2:2004(E).

⁽³⁾With 40 V external suppressor referred to ground (-40°C < T_j < 150°C).

4.3 MCU I/Os protection

If a ground protection network is used and negative transients are present on the V_{CC} line, the control pins will be pulled negative. ST suggests to insert a resistor (R_{prot}) in line both to prevent the microcontroller I/O pins to latch-up and to protect the HSD inputs.

The value of these resistors is a compromise between the leakage current of microcontroller and the current required by the HSD I/Os (Input levels compatibility) with the latch-up limit of microcontroller I/Os.

Equation

$$V_{CCpeak}/I_{latchup} \leq R_{prot} \leq (V_{OH\mu C} - V_{IH} - V_{GND}) / I_{IHmax}$$

Calculation example:

For V_{CCpeak} = -150 V; I_{latchup} ≥ 20 mA; V_{OHμC} ≥ 4.5 V

7.5 kΩ ≤ R_{prot} ≤ 140 kΩ.

Recommended values: R_{prot} = 15 kΩ

4.4 Behaviour during engine start transients

The battery voltage drops every time an engine start occurs as well as in start&stop automotive systems.

The device is designed to operate during engine start pulses without external components.

In particular, the device achieves functional status A, for both E-11 start pulses, "normal" and "severe" as defined in [Table 14: "Test parameters, E-11 Start pulses"](#).

Functional status A is defined as follows: the DUT (device under test) must fulfill all functions during and after exposure to the test parameters.

Table 14: Test parameters, E-11 Start pulses

Parameter	Test pulse “normal”	Test pulse “severe”
V_B	11,0 V	11,0 V
V_T	4,5 V (0%, -4%)	3,2 V $^{+0,2V}$
V_S	4,5 V (0%, -4%)	5,0 V (0%, -4%)
V_A	6,5 V (0%, -4%)	6,0 V (0%, -4%)
V_R	2 V	2 V
t_f	≤ 1 ms	≤ 1 ms
t_4	0 ms	19 ms
t_5	0 ms	≤ 1 ms
t_6	19 ms	329 ms
t_7	50 ms	50 ms
t_8	10 s	10 s
t_r	100 ms	100 ms
f	2 Hz	2 Hz
Break between two cycles	2 s	2 s
Test cycles	10	10



For more details see standard norm “LV124 - Electric and Electronic Components in Motor Vehicles up to 3.5 t”.

Figure 33: Cranking profile

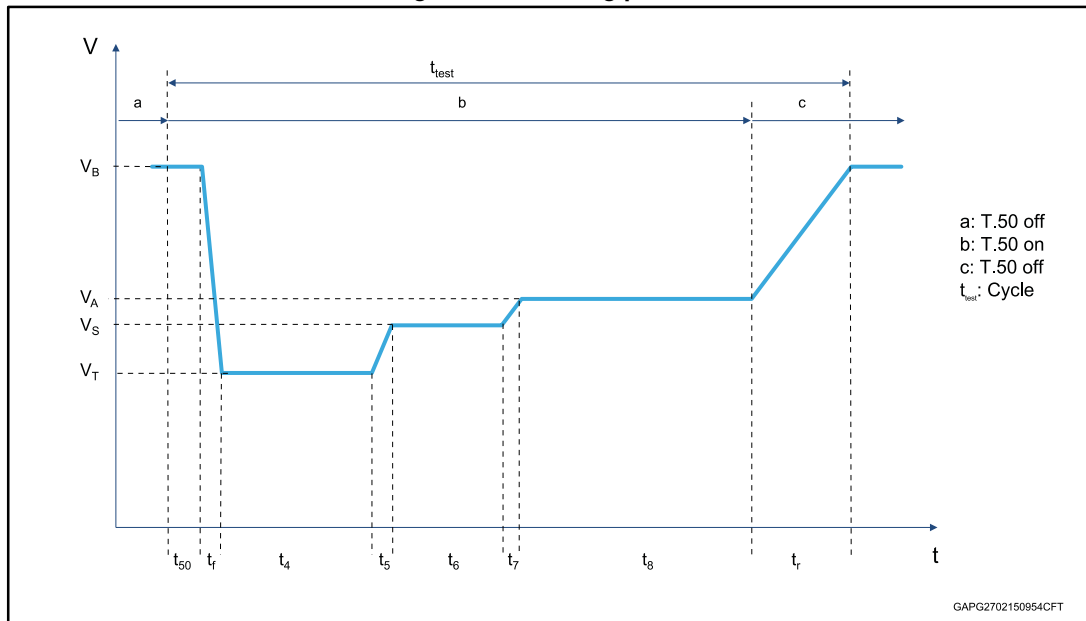

The extremely low $V_{USD_Cranking}$, minimum cranking supply voltage (V_{CC} decreasing), specification of 2.85 V, much lower than the standard requirement, allows the device

operating in all the applications where a ground network protection is required (see [Section 4.1: "GND protection network against reverse battery"](#)).

Table 15: Cranking operating mode

Operating range	Voltage range	Operating mode
Normal mode 4 V to 28 V	18 V - 28 V	All functions are performed as specified. Some deviations of the electrical characteristics.
	7 V - 18 V	All functions are performed as specified. All parameters in range.
	4 V - 7 V	All functions are performed as specified. Some deviations of the electrical characteristics.
Cranking mode 2.85 V to 4 V	2.85 V - 4 V	Device is operating (V_{CC} decreasing). Device is protected. No diagnostic. Electrical parameters deviations.

4.5 CurrentSense - analog current sense

Diagnostic information on device and load status are provided by an analog output pin (CurrentSense) delivering a current mirror of channel output current

Figure 34: CurrentSense and diagnostic – block diagram

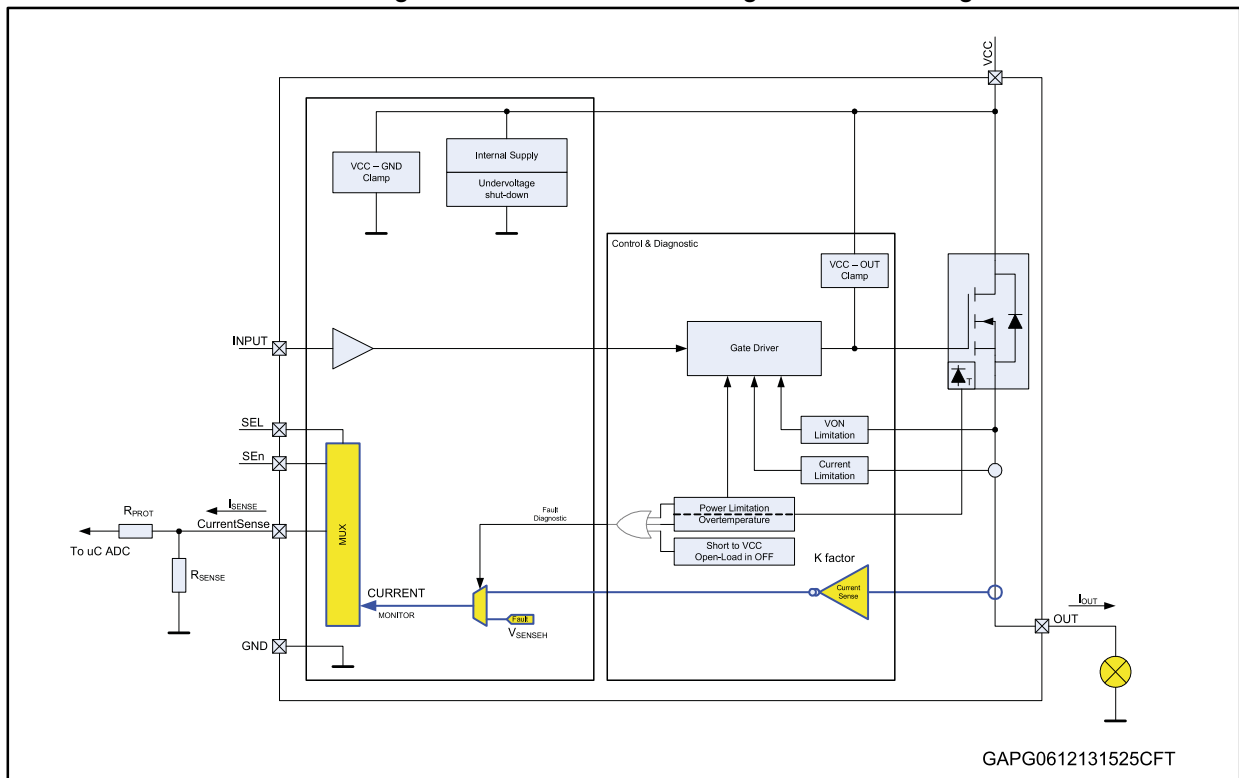

4.5.1 Principle of CurrenSense signal generation

Figure 35: CurrentSense block diagram

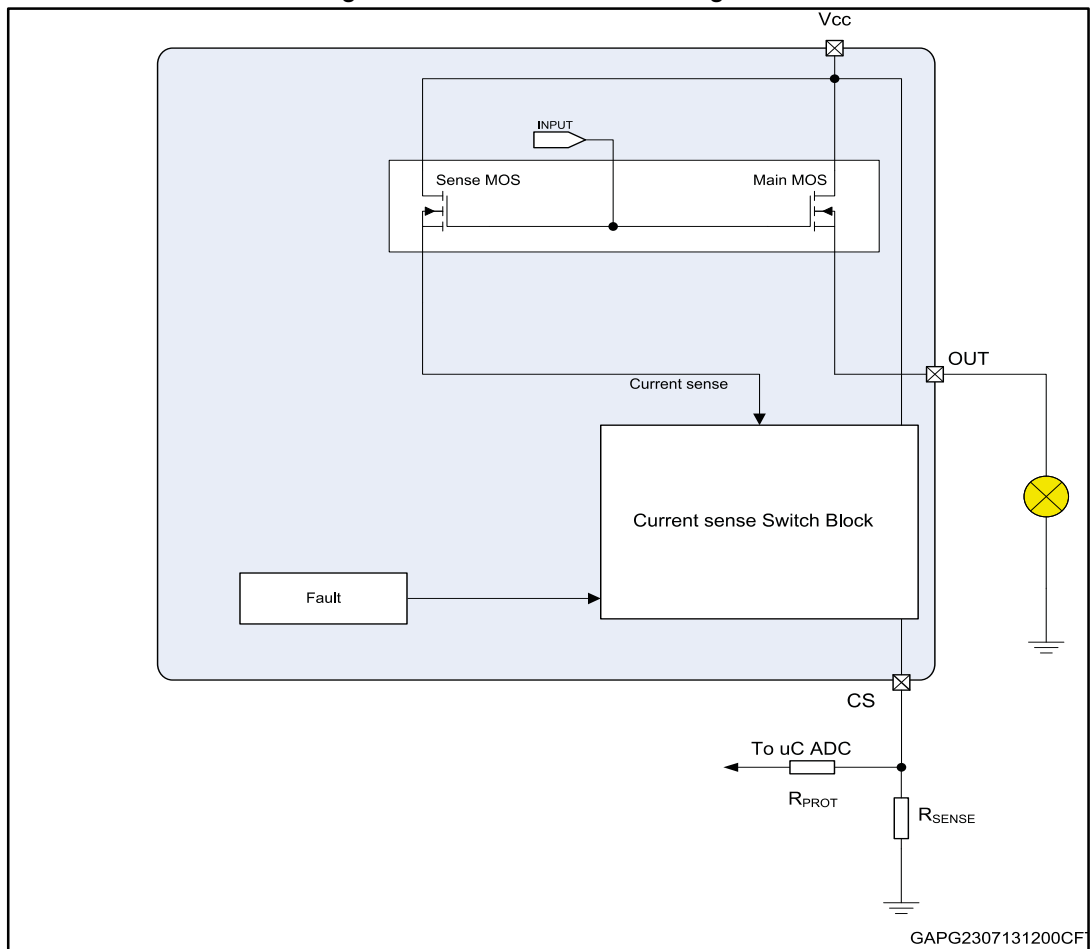

Current monitor

This output is capable of providing:

- **Current mirror proportional to the load current in normal operation**, delivering current proportional to the load according to known ratio named **K**
- **Diagnostics flag in fault conditions** delivering fixed voltage V_{SENSEH}

The current delivered by the current sense circuit, I_{SENSE} , can be easily converted to a voltage V_{SENSE} by using an external sense resistor, R_{SENSE} , allowing continuous load monitoring and abnormal condition detection.

Normal operation (channel ON, no fault, SEn active)

While device is operating in normal conditions (no fault intervention), V_{SENSE} calculation can be done using simple equations

Current provided by CurrentSense output: $I_{SENSE} = I_{OUT}/K$

Voltage on R_{SENSE} : $V_{SENSE} = R_{SENSE} \cdot I_{SENSE} = R_{SENSE} \cdot I_{OUT}/K$

Where :

- V_{SENSE} is voltage measurable on R_{SENSE} resistor

- I_{SENSE} is current provided from CurrentSense pin in current output mode
- I_{OUT} is current flowing through output
- K factor represents the ratio between PowerMOS cells and SenseMOS cells; its spread includes geometric factor spread, current sense amplifier offset and process parameters spread of overall circuitry specifying ratio between I_{OUT} and I_{SENSE} .

Failure flag indication

In case of power limitation/overtemperature, the fault is indicated by the CurrentSense pin which is switched to a “current limited” voltage source, V_{SENSEH} .

In any case, the current sourced by the CurrentSense in this condition is limited to I_{SENSEH} .

The typical behavior in case of overload or hard short circuit is shown in *Waveforms section*.

Figure 36: Analogue HSD – open-load detection in off-state

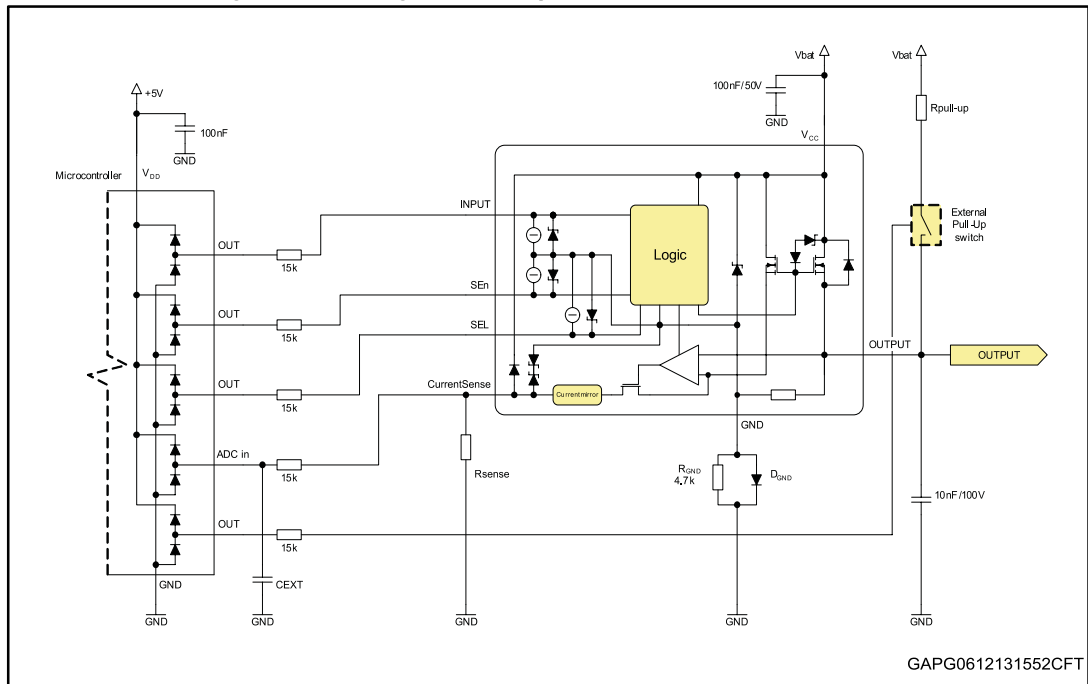

Figure 37: Open-load / short to VCC condition

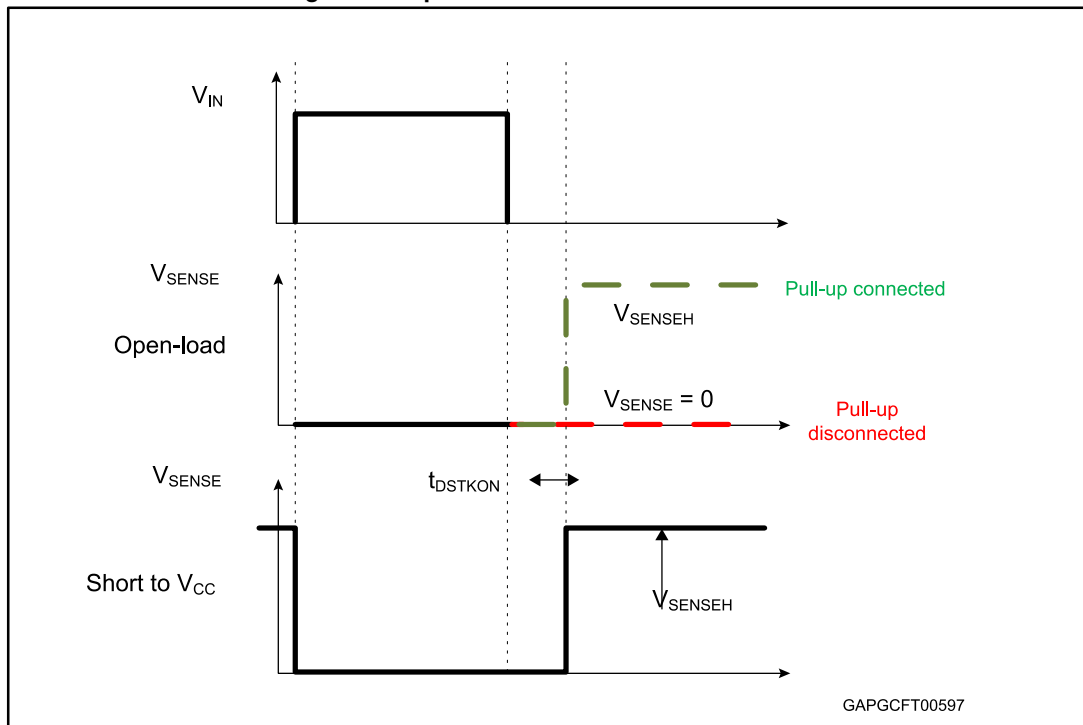

Table 16: CurrentSense pin levels in off-state

Condition	Output	CurrentSense	SEn
Open-load	$V_{OUT} > V_{OL}$	Hi-Z	L
		V_{SENSEH}	H
	$V_{OUT} < V_{OL}$	Hi-Z	L
		0	H
Short to V_{CC}	$V_{OUT} > V_{OL}$	Hi-Z	L
		V_{SENSEH}	H
Nominal	$V_{OUT} < V_{OL}$	Hi-Z	L
		0	H

4.5.2 Short to VCC and OFF-state open-load detection

Short to V_{CC}

A short circuit between V_{CC} and output is indicated by the relevant current sense pin set to V_{SENSEH} during the device off-state. Small or no current is delivered by the current sense during the on-state depending on the nature of the short circuit.

OFF-state open-load with external circuitry

Detection of an open-load in off mode requires an external pull-up resistor R_{PU} connecting the output to a positive supply voltage V_{PU} .

It is preferable V_{PU} to be switched off during the module standby mode in order to avoid the overall standby current consumption to increase in normal conditions, i.e. when load is connected.

R_{PU} must be selected in order to ensure $V_{OUT} > V_{OLmax}$ in accordance with the following equation:

Equation

$$R_{PU} < \frac{V_{PU} - 4}{I_{L(off2)min @ 4V}}$$

5 Maximum demagnetization energy (VCC = 16 V)

Figure 38: Maximum turn off current versus inductance

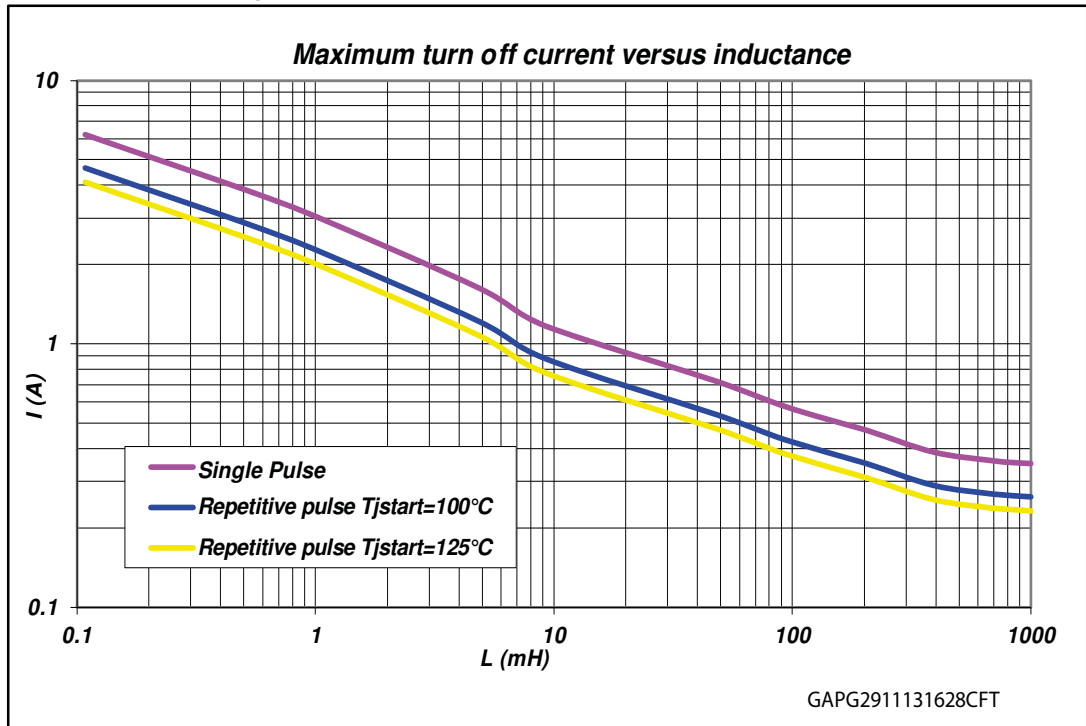

Values are generated with $R_L = 0 \Omega$.

In case of repetitive pulses, T_{jstart} (at the beginning of each demagnetization) of every pulse must not exceed the temperature specified above for curves A and B.

6 Package and PCB thermal data

6.1 PowerSSO-12 thermal data

Figure 39: PowerSSO-12 on two-layers PCB (2s0p to JEDEC JESD 51-5)

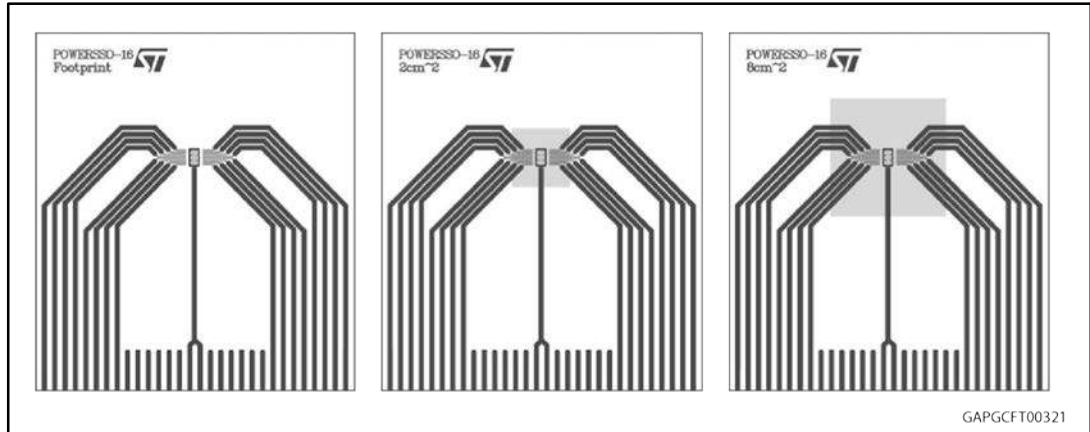

Figure 40: PowerSSO-12 on four-layers PCB (2s2p to JEDEC JESD 51-7)

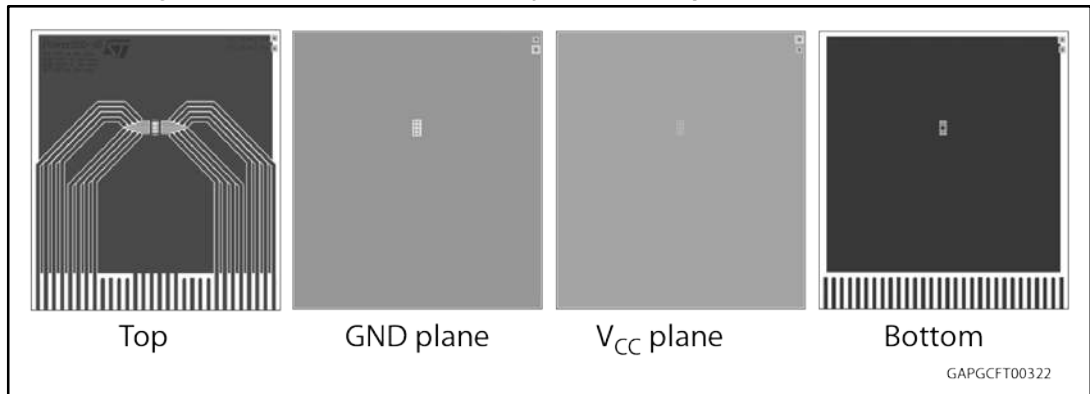

Table 17: PCB properties

Dimension	Value
Board finish thickness	1.6 mm +/- 10%
Board dimension	77 mm x 86 mm
Board material	FR4
Copper thickness (top and bottom layers)	0.070 mm
Copper thickness (inner layers)	0.035 mm
Thermal via separation	1.2 mm
Thermal via diameter	0.3 mm +/- 0.08 mm
Copper thickness on via	0.025 mm
Footprint dimension (top layer)	2.2 mm x 3.9 mm
Heatsink copper area dimension (bottom layer)	Footprint, 2 cm ² or 8 cm ²

Figure 41: Rthj-amb vs PCB copper area in open box free air condition (one channel on)

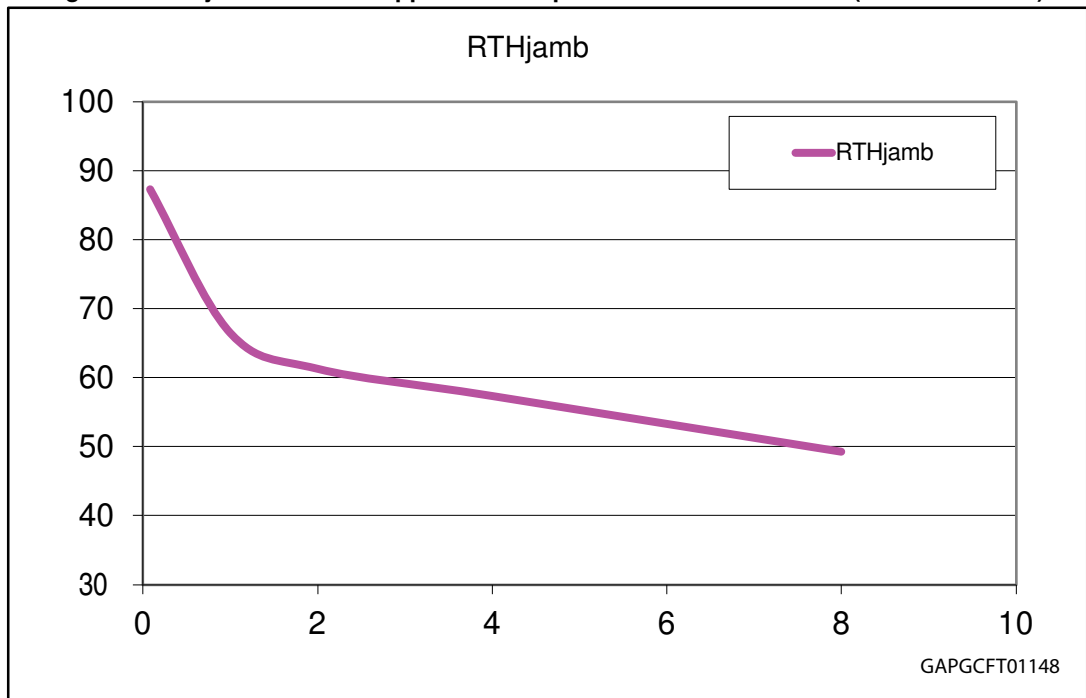
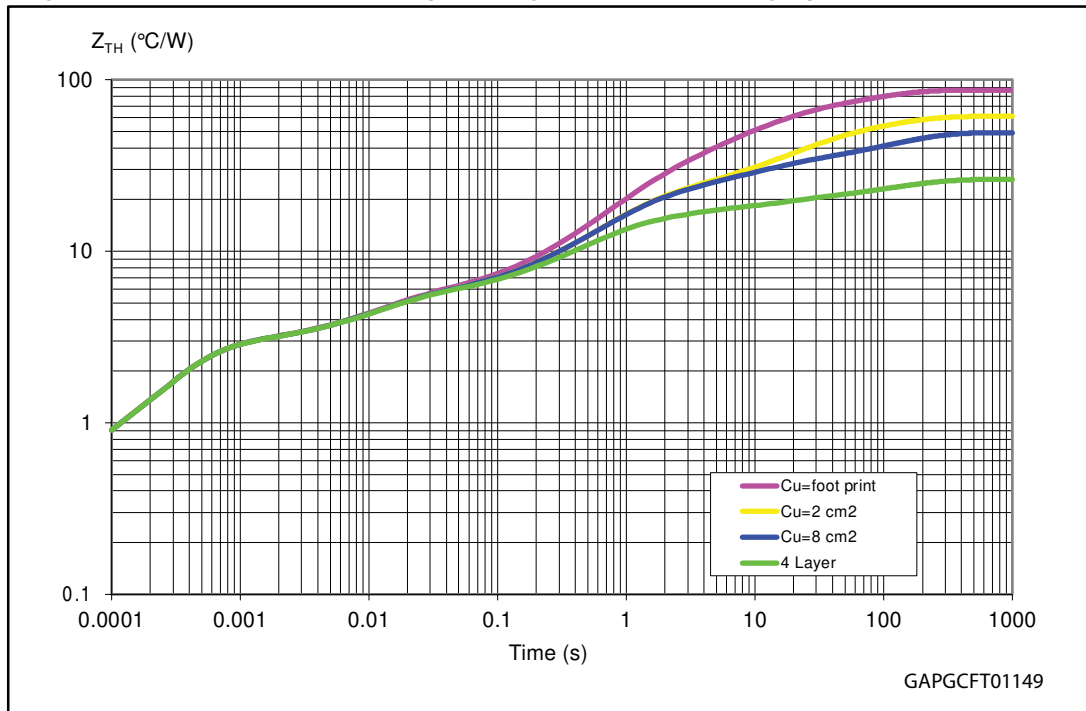

Figure 42: PowerSSO-12 thermal impedance junction ambient single pulse (one channel on)



Equation: pulse calculation formula

$$Z_{TH\delta} = R_{TH} \cdot \delta + Z_{THtp} (1 - \delta)$$

where $\delta = t_p/T$

Figure 43: Thermal fitting model of a double-channel HSD in PowerSSO-12

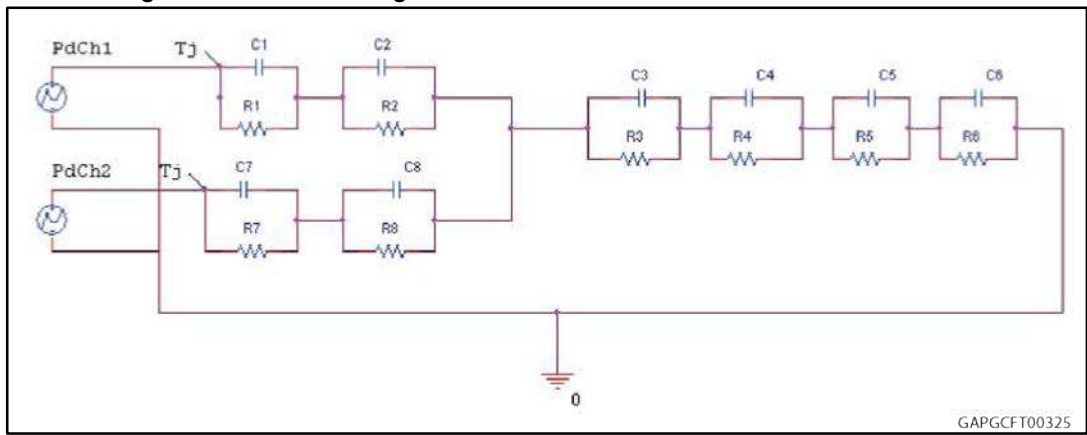

The fitting model is a simplified thermal tool and is valid for transient evolutions where the embedded protections (power limitation or thermal cycling during thermal shutdown) are not triggered.

Table 18: Thermal parameters

Area/island (cm ²)	Footprint	2	8	4L
R1 = R7 (°C/W)	2.8			
R2 = R8 (°C/W)	2.5			
R3 (°C/W)	10	10	10	7
R4 (°C/W)	16	6	6	4
R5 (°C/W)	30	20	10	3
R6 (°C/W)	26	20	18	7
C1 = C7 (W.s/°C)	0.00012			
C2 = C8 (W.s/°C)	0.005			
C3 (W.s/°C)	0.07			
C4 (W.s/°C)	0.2	0.3	0.3	0.4
C5 (W.s/°C)	0.4	1	1	4
C6 (W.s/°C)	3	5	7	18

7 Package information

In order to meet environmental requirements, ST offers these devices in different grades of ECOPACK® packages, depending on their level of environmental compliance. ECOPACK® specifications, grade definitions and product status are available at: www.st.com. ECOPACK® is an ST trademark.

7.1 PowerSSO-12 package information

Figure 44: PowerSSO-12 package dimensions

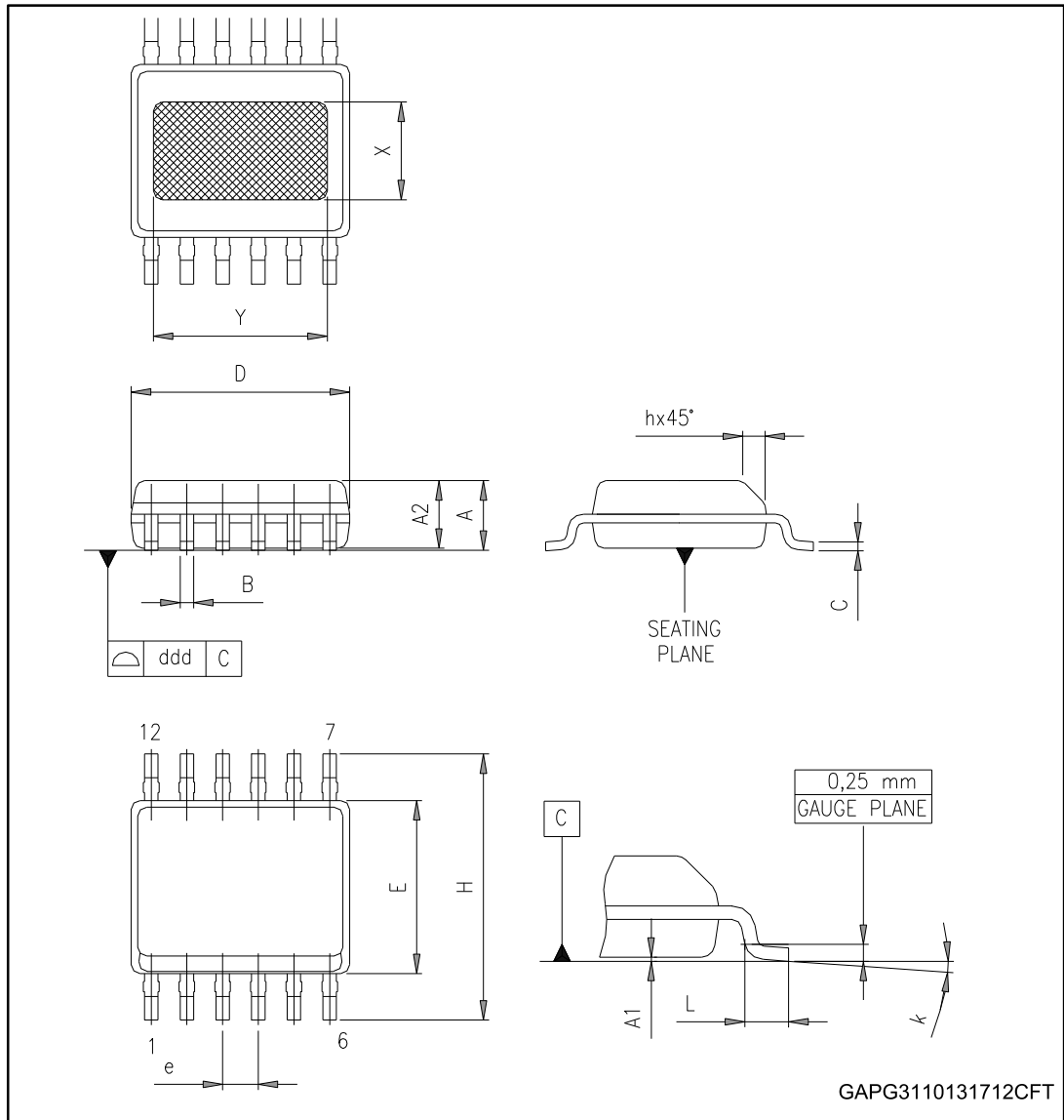

Table 19: PowerSSO-12 mechanical data

Symbol	Millimeters		
	Min.	Typ.	Max.
A	1.250		1.700
A1	0.000		0.100
A2	1.100		1.600
B	0.230		0.410
C	0.190		0.250
D	4.800		5.000
E	3.800		4.000
e		0.800	
H	5.800		6.200
h	0.250		0.500
L	0.400		1.270
k	0°		8°
X	2.200		2.800
Y	2.900		3.500
ddd			0.100

7.2 PowerSSO-12 packing information

Figure 45: PowerSSO-12 reel 13"

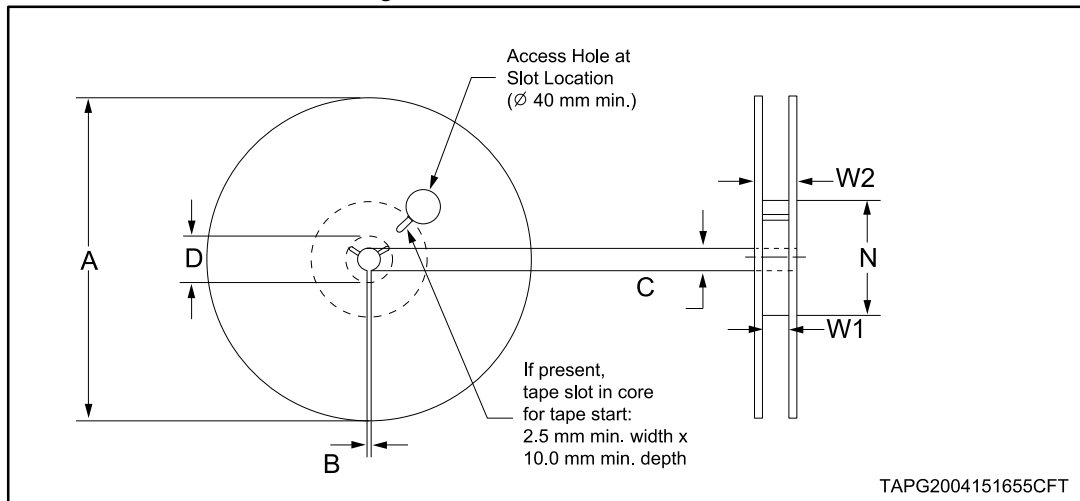

Table 20: Reel dimensions

Description	Value ⁽¹⁾
Base quantity	2500
Bulk quantity	2500
A (max)	330
B (min)	1.5

Description	Value ⁽¹⁾
C (+0.5, -0.2)	13
D (min)	20.2
N	100
W1 (+2 /-0)	12.4
W2 (max)	18.4

Notes:

(1)All dimensions are in mm.

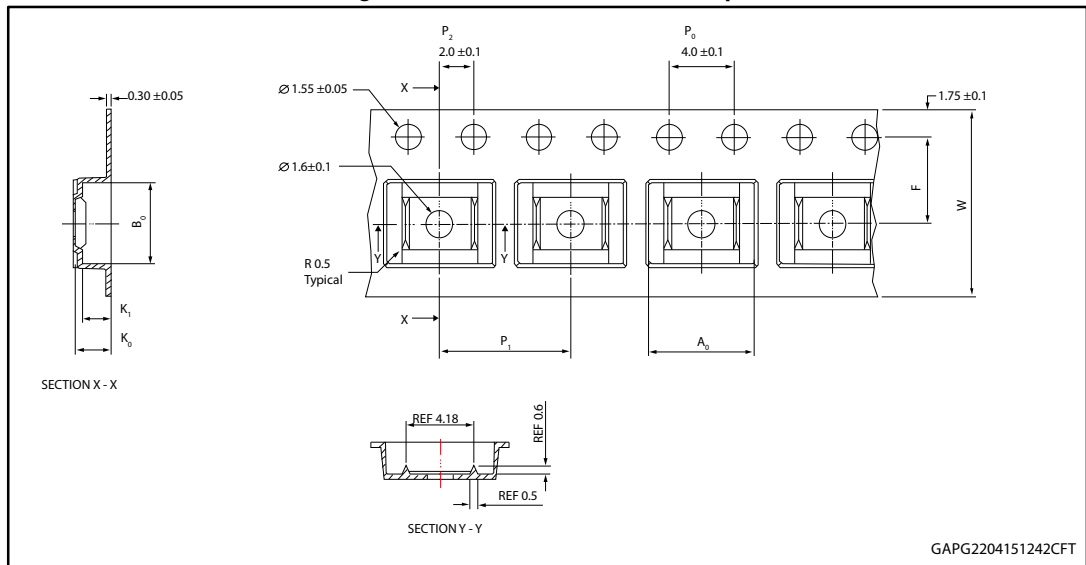
Figure 46: PowerSSO-12 carrier tape**Table 21: PowerSSO-12 carrier tape dimensions**

Description	Value ⁽¹⁾
A_0	6.50 ± 0.1
B_0	5.25 ± 0.1
K_0	2.10 ± 0.1
K_1	1.80 ± 0.1
F	5.50 ± 0.1
P_1	8.00 ± 0.1
W	12.00 ± 0.3

Notes:

(1)All dimensions are in mm.

Figure 47: PowerSSO-12 schematic drawing of leader and trailer tape

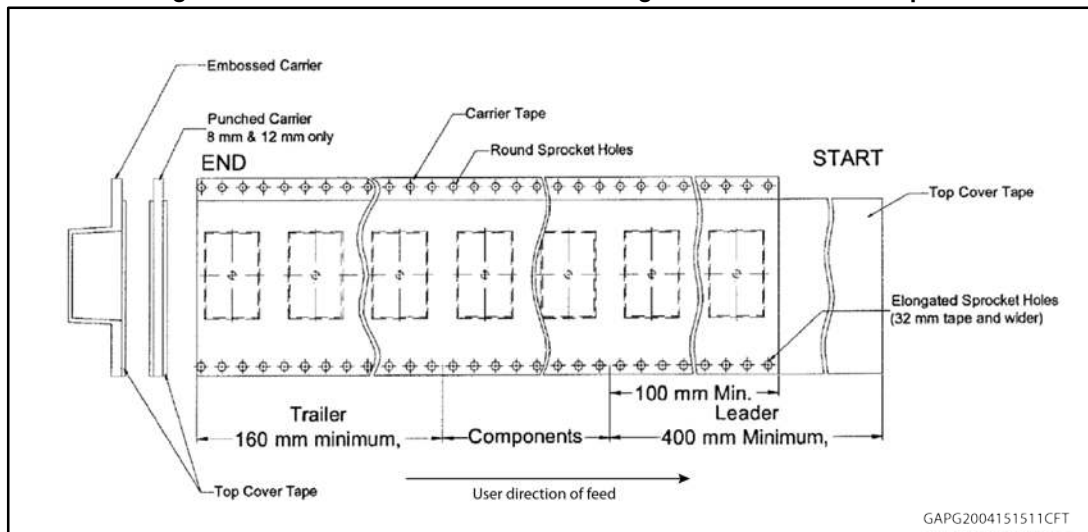

7.3 PowerSSO-12 marking information

Figure 48: PowerSSO-12 marking information

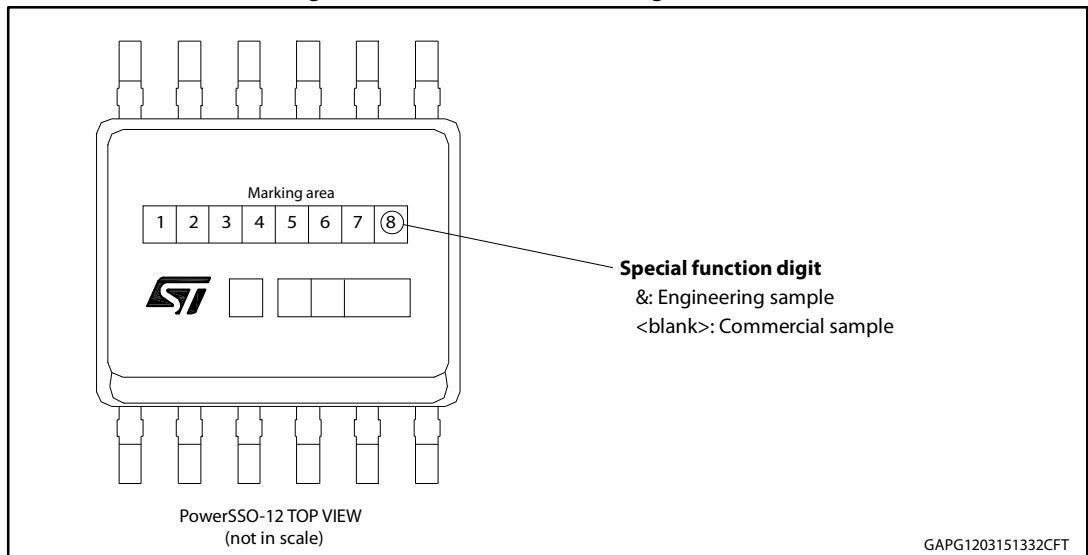

Engineering Samples: these samples can be clearly identified by a dedicated special symbol in the marking of each unit. These samples are intended to be used for electrical compatibility evaluation only; usage for any other purpose may be agreed only upon written authorization by ST. ST is not liable for any customer usage in production and/or in reliability qualification trials.

Commercial Samples: Fully qualified parts from ST standard production with no usage restrictions

8 Order codes

Table 22: Device summary

Package	Order codes
	Tape and reel
PowerSSO-12	VND7140AJ12TR

9 Revision history

Table 23: Document revision history

Date	Revision	Changes
09-Jun-2015	1	Initial release.
18-Jun-2015	2	<i>Table 5: "Electrical characteristics during cranking":</i> <ul style="list-style-type: none">• T_{TSD}: updated value <i>Table 10: "CurrentSense":</i> <ul style="list-style-type: none">• K_{OL}, K_{LED}, K_0, K_1: updated values Updated <i>Section 2.5: "Electrical characteristics curves"</i>
14-Sep-2015	3	Updated <i>Table 1: "Pin functions"</i> <i>Table 5: "Electrical characteristics during cranking":</i> <ul style="list-style-type: none">• R_{ON}: updated test conditions

IMPORTANT NOTICE – PLEASE READ CAREFULLY

STMicroelectronics NV and its subsidiaries ("ST") reserve the right to make changes, corrections, enhancements, modifications, and improvements to ST products and/or to this document at any time without notice. Purchasers should obtain the latest relevant information on ST products before placing orders. ST products are sold pursuant to ST's terms and conditions of sale in place at the time of order acknowledgement.

Purchasers are solely responsible for the choice, selection, and use of ST products and ST assumes no liability for application assistance or the design of Purchasers' products.

No license, express or implied, to any intellectual property right is granted by ST herein.

Resale of ST products with provisions different from the information set forth herein shall void any warranty granted by ST for such product.

ST and the ST logo are trademarks of ST. All other product or service names are the property of their respective owners.

Information in this document supersedes and replaces information previously supplied in any prior versions of this document.

© 2015 STMicroelectronics – All rights reserved