

**FAST RECOVERY RECTIFIER**

**VOLTAGE RANGE 1000 to 1800 Volts CURRENT 0.5 Ampere**

**FEATURES**

- \* Fast switching
- \* Low leakage
- \* Low forward voltage drop
- \* High current capability
- \* High current surge
- \* High reliability

**MECHANICAL DATA**

- \* Case: Molded plastic
- \* Epoxy: Device has UL flammability classification 94V-O
- \* Lead: MIL-STD-202E method 208C guaranteed
- \* Mounting position: Any

**MAXIMUM RATINGS AND ELECTRICAL CHARACTERISTICS**

Ratings at 25°C ambient temperature unless otherwise specified.  
Single phase, half wave, 60 Hz, resistive or inductive load.  
For capacitive load, derate current by 20%.

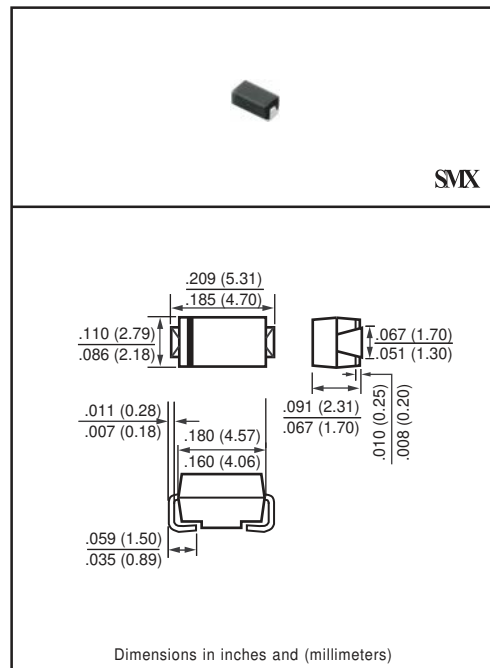

**MAXIMUM RATINGS (At TA = 25°C unless otherwise noted)**

RATINGS	SYMBOL	FFM1000W	FFM1200W	FFM1400W	FFM1500W	FFM1600W	FFM1800W	UNITS
Maximum Recurrent Peak Reverse Voltage	V <sub>RRM</sub>	1000	1200	1400	1500	1600	1800	Volts
Maximum RMS Voltage	V <sub>RMS</sub>	700	840	980	1050	1120	1260	Volts
Maximum DC Blocking Voltage	V <sub>DC</sub>	1000	1200	1400	1500	1600	1800	Volts
Maximum Average Forward Rectified Current at TA = 25°C	I <sub>O</sub>	0.5						Amps
Peak Forward Surge Current 8.3 ms single half sine-wave superimposed on rated load (JEDEC method)	I <sub>FSM</sub>	25						Amps
Typical Current Squared Time	I <sup>2</sup> <sub>t</sub>	2.6						A <sup>2</sup> S
Typical Junction Capacitance (Note 2)	C <sub>J</sub>	15						pF
Operating and Storage Temperature Range	T <sub>J</sub> , T <sub>STG</sub>	-55 to + 150						°C

**ELECTRICAL CHARACTERISTICS (At TA = 25°C unless otherwise noted)**

CHARACTERISTICS	SYMBOL	FFM1000W	FFM1200W	FFM1400W	FFM1500W	FFM1600W	FFM1800W	UNITS
Maximum Instantaneous Forward Voltage at 0.5A DC	V <sub>F</sub>	1.8						Volts
Maximum DC Reverse Current at Rated DC Blocking Voltage TA = 25°C	I <sub>R</sub>	5.0						uAmps
Maximum Full Load Reverse Current Full Cycle Average, .375" (9.5mm) lead length at TL = 55°C	I <sub>R</sub>	100						uAmps
Maximum Reverse Recovery Time (Note 1)	t <sub>rr</sub>	300						nSec

NOTES : 1. Reverse Recovery Test Conditions: I<sub>F</sub> = 0.5A, I<sub>R</sub> = -1.0A, I<sub>RR</sub> = -0.25A  
2. Measured at 1 MHz and applied reverse voltage of 4.0 volts

2017-2  
REV:A

## RATING AND CHARACTERISTIC CURVES ( FFM1000W THRU FFM1800W )

FIG. 1 - TYPICAL FORWARD CURRENT DERATING CURVE

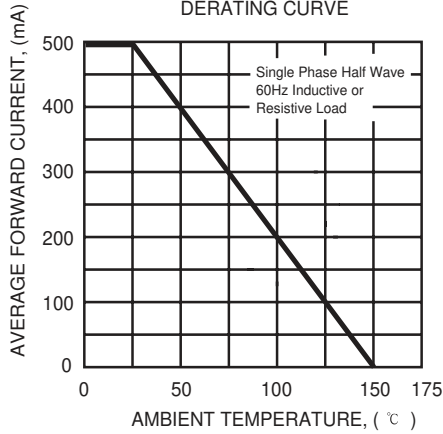

FIG. 2 - MAXIMUM NON-REPETITIVE FORWARD SURGE CURRENT

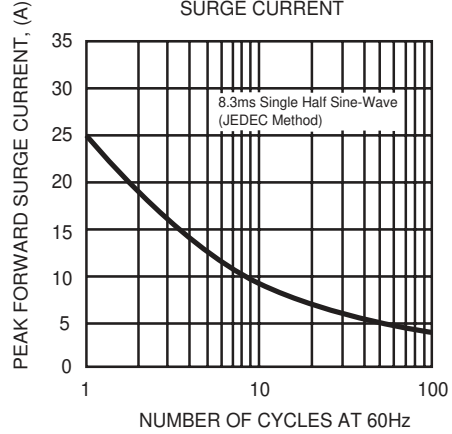
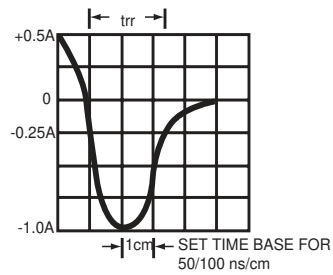
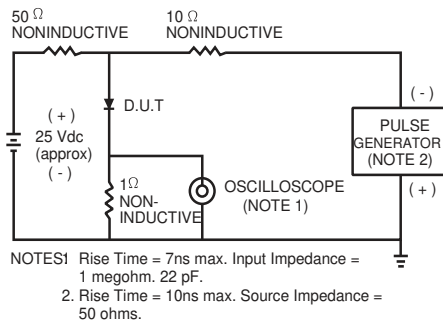
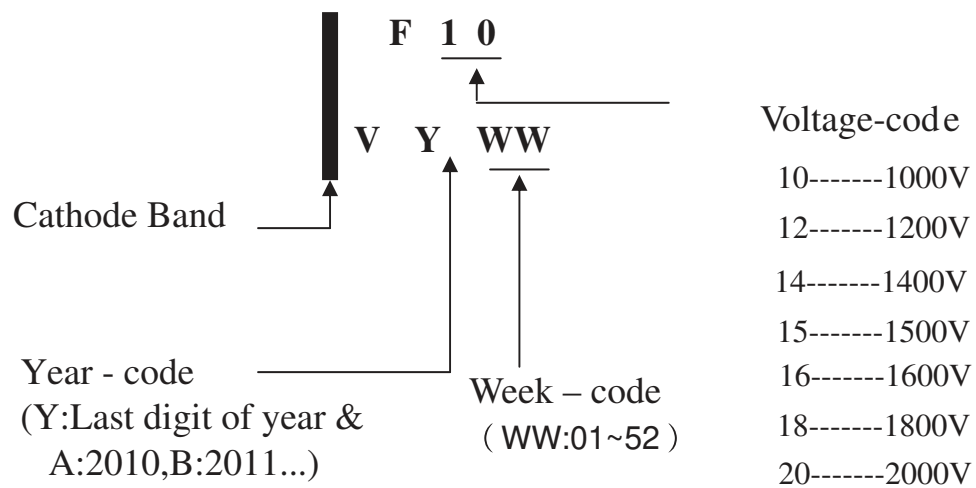

FIG. 3 - TEST CIRCUIT DIAGRAM AND REVERSE RECOVERY TIME CHARACTERISTIC



## Marking Description



## PACKAGING OF DIODE AND BRIDGE RECTIFIERS

### REEL PACK

PACKAGE	PACKING CODE	EA PER REEL	EA PER INNER BOX	COMPONENT SPACE (mm)	TAPE SPACE (mm)	REEL DIA (mm)	CARTON SIZE (mm)	EA PER CARTON	GROSS WEIGHT(Kg)
SMX	-T	1,500	6,000	---	---	178	390*205*310	48,000	---
SMX	-W	5,000	10,000	---	---	330	360*355*360	80,000	15.20

## DISCLAIMER NOTICE

Rectron Inc reserves the right to make changes without notice to any product specification herein, to make corrections, modifications, enhancements or other changes. Rectron Inc or anyone on its behalf assumes no responsibility or liability for any errors or inaccuracies. Data sheet specifications and its information contained are intended to provide a product description only. "Typical" parameters which may be included on RECTRON data sheets and/ or specifications can and do vary in different applications and actual performance may vary over time. Rectron Inc does not assume any liability arising out of the application or use of any product or circuit.

Rectron products are not designed, intended or authorized for use in medical, life-saving implant or other applications intended for life-sustaining or other related applications where a failure or malfunction of component or circuitry may directly or indirectly cause injury or threaten a life without expressed written approval of Rectron Inc. Customers using or selling Rectron components for use in such applications do so at their own risk and shall agree to fully indemnify Rectron Inc and its subsidiaries harmless against all claims, damages and expenditures.