

Features

- Rail-to-rail output swing
- -3dB bandwidth = 100MHz
- Single supply +5V operation
- Power-down to 2.6µA
- Large input common mode range $0V < V_{CM} < 3.5V$
- Diff Gain/Phase = 0.1%/0.1°
- Low power 35mW per amplifier

Applications

- Video amplifiers
- 5V analog signal processing
- Multiplexers
- Line drivers

Ordering Information

Part No	Package	Tape & Reel	Outline #
EL5144CW	SOT-23	-	MDP0038
EL5144CW-T7	SOT-23	7 in	MDP0038
EL5144CW-T13	SOT-23	13 in	MDP0038
EL5146CN	PDIP-8	-	MDP0031
EL5146CS	SO-8	-	MDP0027
EL5146CS-T7	SO-8	7 in	MDP0027
EL5146CS-T13	SO-8	13 in	MDP0027
EL5244CN	PDIP-8	-	MDP0031
EL5244CS	SO-8	-	MDP0027
EL5244CS-T7	SO-8	7 in	MDP0027
EL5244CS-T13	SO-8	13 in	MDP0027
EL5244CY	MSOP-8	-	MDP0043
EL5244CY-T7	MSOP-8	7 in	MDP0043
EL5244CY-T13	MSOP-8	13 in	MDP0043
EL5246CN	PDIP-14	-	MDP0031
EL5246CS	SO-14	-	MDP0027
EL5246CS-T7	SO-14	7 in	MDP0027
EL5246CS-T13	SO-14	13 in	MDP0027
EL5246CY	MSOP-10	-	MDP0043
EL5246CY-T7	MSOP-10	7 in	MDP0043
EL5246CY-T13	MSOP-10	13 in	MDP0043
EL5444CN	PDIP-14	-	MDP0031
EL5444CS	SO-14	-	MDP0027
EL5444CS-T7	SO-14	7 in	MDP0027
EL5444CS-T13	SO-14	13 in	MDP0027
EL5444CU	QSOP-16	-	MDP0040
EL5444CU-T13	QSOP-16	13 in	MDP0040
EL5444CR	TSSOP-14	-	MDP0044
EL5444CR-T7	TSSOP-14	7 in	MDP0044
EL5444CR-T13	TSSOP-14	13 in	MDP0044

General Description

The EL5144C series amplifiers are voltage feedback, high speed, rail-to-rail amplifiers designed to operate on a single +5V supply. They offer unity gain stability with an unloaded -3dB bandwidth of 100MHz. The input common mode voltage range extends from the negative rail to within 1.5V of the positive rail. Driving a 75Ω double terminated coaxial cable, the EL5144C series amplifiers drive to within 150mV of either rail. The 200V/µS slew rate and 0.1%/0.1° differential gain/differential phase makes these parts ideal for composite and component video applications. With its voltage feedback architecture, this amplifier can accept reactive feedback networks, allowing them to be used in analog filtering applications. These amplifiers will source 90mA and sink 65mA.

The EL5146C and EL5246C have a power-savings disable feature. Applying a standard TTL low logic level to the CE (Chip Enable) pin reduces the supply current to 2.6µA within 10ns. Turn-on time is 500ns, allowing true break-before-make conditions for multiplexing applications. Allowing the CE pin to float or applying a high logic level will enable the amplifier.

For applications where board space is critical, singles are offered in a 5-pin SOT23 package, duals in 8-pin & 10-pin MSOP packages, and quads in 16-pin QSOP and 14-pin TSSOP packages. Singles, duals, and quads are also available in the industry-standard pinouts in SO and PDIP packages. All parts operate over the full -40°C to +85°C temperature range.

Pin Configurations

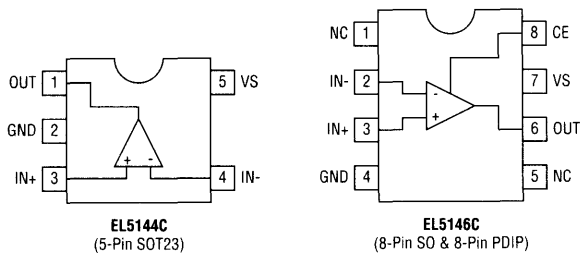

Dual and Quad Amplifier Pin Configurations on Page 3

EL5144C, EL5146C, EL5244C, EL5246C, EL5444C

100MHz Single Supply Rail-to-Rail Amplifier

Absolute Maximum Ratings (T_A = 25°C)

Values beyond absolute maximum ratings can cause the device to be prematurely damaged. Absolute maximum ratings are stress ratings only and functional device operation is not implied.

Supply Voltage between V_S and GND +6V
 Maximum Continuous Output Current 50mA

Power Dissipation
 Pin Voltages
 Die Junction Temperature
 Storage Temperature
 Operating Temperature

See Curves
 GND - 0.5V to V_S +0.5V
 150°C
 -65°C to +150°C
 -40°C to +85°C

Important Note:

All parameters having Min/Max specifications are guaranteed. Typ values are for information purposes only. Unless otherwise noted, all tests are at the specified temperature and are pulsed tests, therefore: T_J = T_C = T_A

Electrical Characteristics

V_S = +5V, GND = 0V, T_A = 25°C, CE = +2V, unless otherwise specified.

Parameter	Description	Conditions	Min	Typ	Max	Unit
AC Performance						
dG	Differential Gain Error ^[1]	G = 2, R _L = 150Ω to 2.5V, R _F = 1kΩ		0.1		%
dP	Differential Phase Error ^[1]	G = 2, R _L = 150Ω to 2.5V, R _F = 1kΩ		0.1		°
BW	Bandwidth	-3dB, G = 1, R _L = 10kΩ, R _F = 0		100		MHz
		-3dB, G = 1, R _L = 150Ω, R _F = 0		60		MHz
BW1	Bandwidth	±0.1dB, G = 1, R _L = 150Ω to GND, R _F = 0		8		MHz
GBWP	Gain Bandwidth Product			60		MHz
SR	Slew Rate	G = 1, R _L = 150Ω to GND, R _F = 0, V _O = 0.5V to 3.5V	150	200		V/μs
t _s	Settling Time	to 0.1%, V _{OUT} = 0V to 3V		35		ns
DC Performance						
A _{VOL}	Open Loop Voltage Gain	R _L = no load, V _{OUT} = 0.5V to 3V	54	65		dB
		R _L = 150Ω to GND, V _{OUT} = 0.5V to 3V	40	50		dB
V _{OS}	Offset Voltage	V _{CM} = 1V, SOT23 and MSOP packages			25	mV
		V _{CM} = 1V, All other packages			15	mV
T _C V _{OS}	Input Offset Voltage Temperature Coefficient			10		mV/°C
I _B	Input Bias Current	V _{CM} = 0V & 3.5V		2	100	nA
Input Characteristics						
CMIR	Common Mode Input Range	CMRR ≥ 47dB	0		3.5	V
CMRR	Common Mode Rejection Ratio	DC, V _{CM} = 0 to 3.0V	50	60		dB
		DC, V _{CM} = 0 to 3.5V	47	60		dB
R _{IN}	Input Resistance			1.5		GΩ
C _{IN}	Input Capacitance			1.5		pF
Output Characteristics						
V _{OP}	Positive Output Voltage Swing	R _L = 150Ω to 2.5V ^[2]	4.70	4.85		V
		R _L = 150Ω to GND ^[2]	4.20	4.65		V
		R _L = 1kΩ to 2.5V ^[2]	4.95	4.97		V
V _{ON}	Negative Output Voltage Swing	R _L = 150Ω to 2.5V ^[2]		0.15	0.30	V
		R _L = 150Ω to GND ^[2]		0		V
		R _L = 1k to 2.5V ^[2]		0.03	0.05	V
+I _{OUT}	Positive Output Current	R _L = 10Ω to 2.5V	60	90	120	mA
-I _{OUT}	Negative Output Current	R _L = 10Ω to 2.5V	-50	-65	-80	mA

EL5144C, EL5146C, EL5244C, EL5246C, EL5444C

100MHz Single Supply Rail-to-Rail Amplifier

EL5144C, EL5146C, EL5244C, EL5246C, EL5444C

Amplifiers

Electrical Characteristics

$V_S = +5V$, $GND = 0V$, $T_A = 25^\circ C$, $CE = +2V$, unless otherwise specified.

Parameter	Description	Conditions	Min	Typ	Max	Unit
Enable (EL5146C & EL5246C Only)						
t_{EN}	Enable Time	EL5146C, EL5246C		500		ns
t_{DIS}	Disable Time	EL5146C, EL5246C		10		ns
I_{IHCE}	CE pin Input High Current	$CE = 5V$, EL5146C, EL5246C		0.003	1	mA
I_{ILCE}	CE pin Input Low Current	$CE = 0V$, EL5146C, EL5246C		-1.2	-3	mA
V_{IHCE}	CE pin Input High Voltage for Power Up	EL5146C, EL5246C	2.0			V
V_{ILCE}	CE pin Input Low Voltage for Power Down	EL5146C, EL5246C			0.8	V
Supply						
I_{SON}	Supply Current - Enabled (per amplifier)	No Load, $V_{IN} = 0V$, $CE = 5V$		7	8.8	mA
I_{SOFF}	Supply Current - Disabled (per amplifier)	No Load, $V_{IN} = 0V$, $CE = 0V$		2.6	5	mA
PSOR	Power Supply Operating Range		4.75	5.0	5.25	V
PSRR	Power Supply Rejection Ratio	DC, $V_S = 4.75V$ to $5.25V$	50	60		dB

1. Standard NTSC test, AC signal amplitude = 286 mV_{p-p}, $f = 3.58MHz$, V_{OUT} is swept from 0.8V to 3.4V. RL is DC coupled
2. R_L is Total Load Resistance due to Feedback Resistor and Load Resistor

EL5144C, EL5146C, EL5244C, EL5246C, EL5444C

100MHz Single Supply Rail-to-Rail Amplifier

Pin Configurations (Continued)

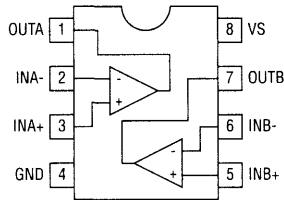

EL5244C
(8-Pin SO, 8-Pin PDIP & 8-Pin MSOP)

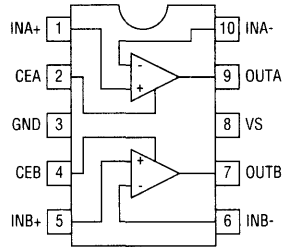

EL5246C
(10-Pin MSOP)

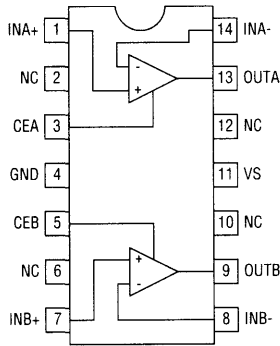

EL5246C
(14-Pin SO & 14-Pin PDIP)

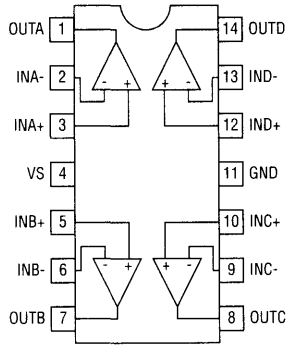

EL5444C
(14-Pin SO, 14-Pin PDIP & 14-Pin TSSOP)

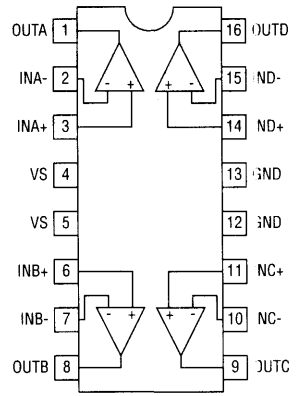

EL5444C
(16-Pin QSOP)

Single Amplifier Pin Configurations on Page 1

EL5144C, EL5146C, EL5244C, EL5246C, EL5444C

100MHz Single Supply Rail-to-Rail Amplifier

EL5144C, EL5146C, EL5244C, EL5246C, EL5444C

Amplifiers

Typical Performance Curves

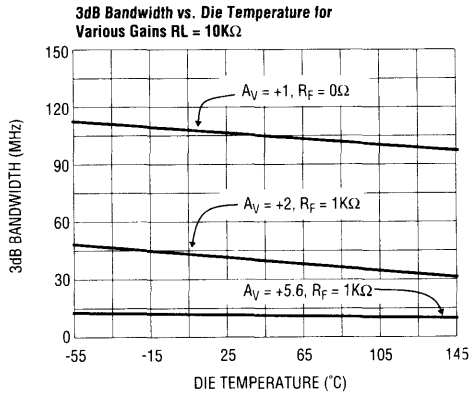
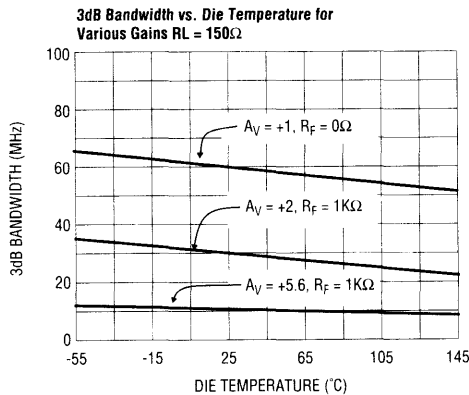
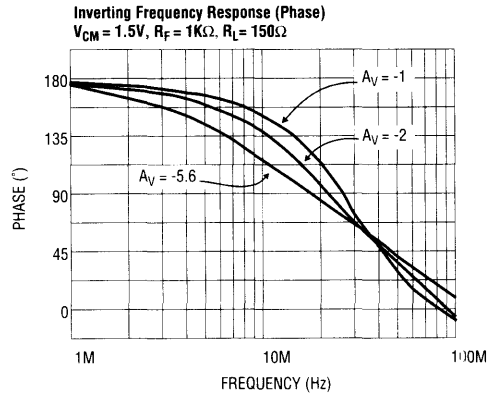
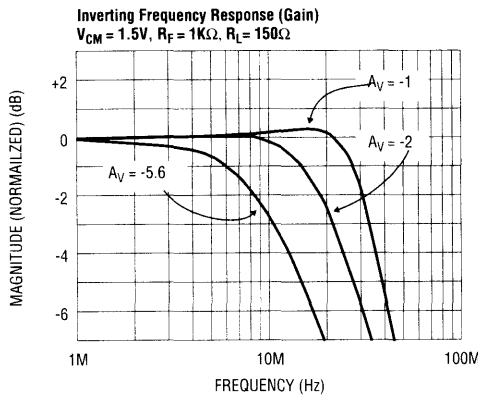
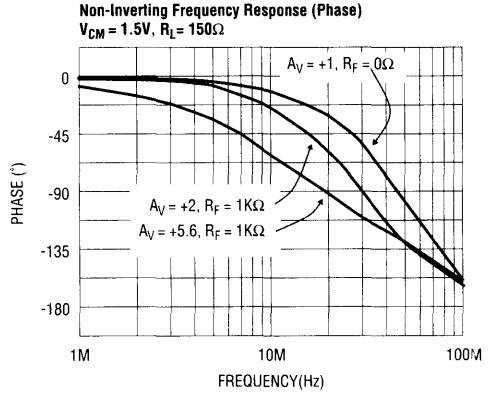
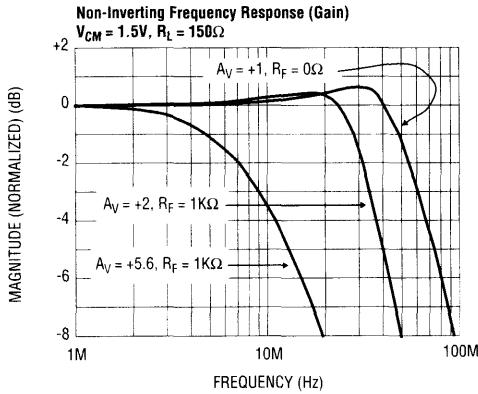

EL5144C, EL5146C, EL5244C, EL5246C, EL5444C

100MHz Single Supply Rail-to-Rail Amplifier

Typical Performance Curves

Frequency Response for Various R_L
 $V_{CM} = 1.5V, R_F = 0\Omega, A_V = +1$

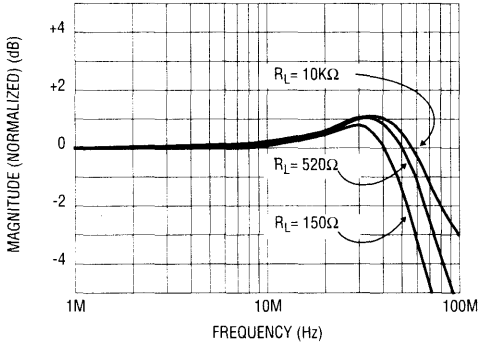

Frequency Response for Various C_L
 $V_{CM} = 1.5V, R_L = 150\Omega, A_V = +1$

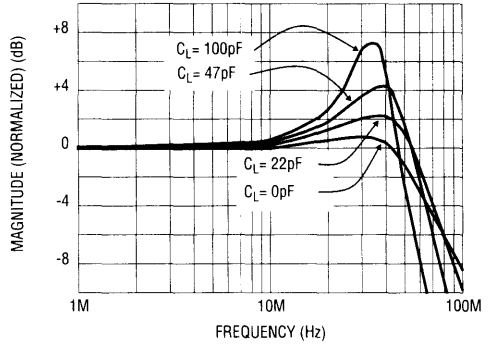

Frequency Response for Various R_F and R_G
 $V_{CM} = 1.5V, R_L = 150\Omega, A_V = +2$

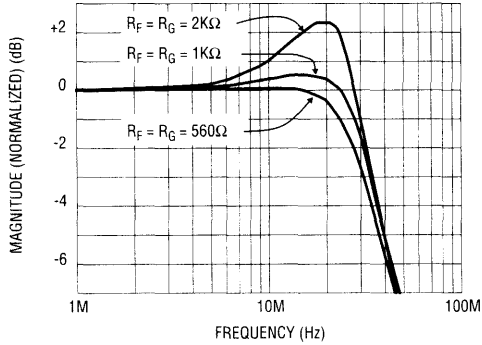

Group Delay vs. Frequency

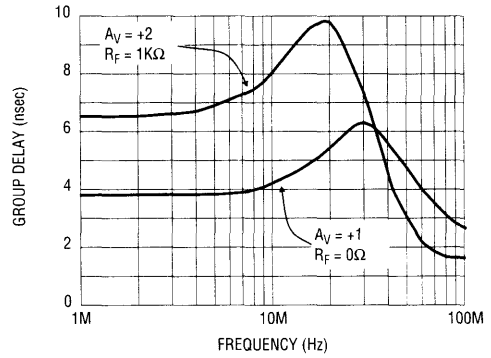

Open Loop Gain and Phase vs. Frequency

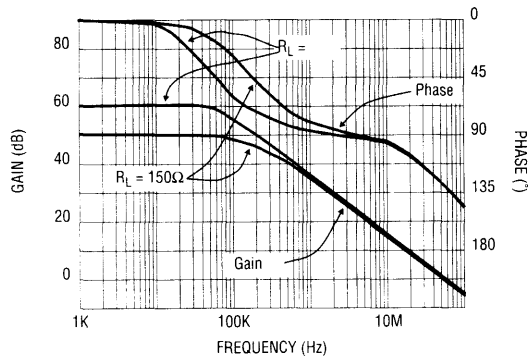

Open Loop Voltage Gain vs. Die Temperature

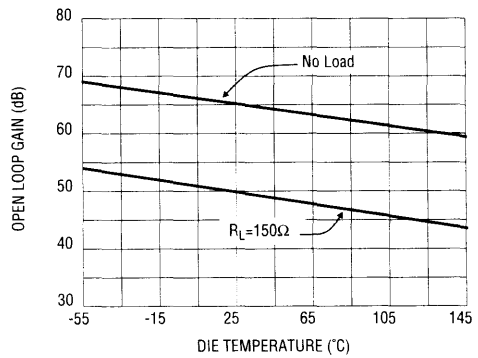

EL5144C, EL5146C, EL5244C, EL5246C, EL5444C

100MHz Single Supply Rail-to-Rail Amplifier

EL5144C, EL5146C, EL5244C, EL5246C, EL5444C

Amplifiers

Typical Performance Curves

Voltage Noise vs. Frequency

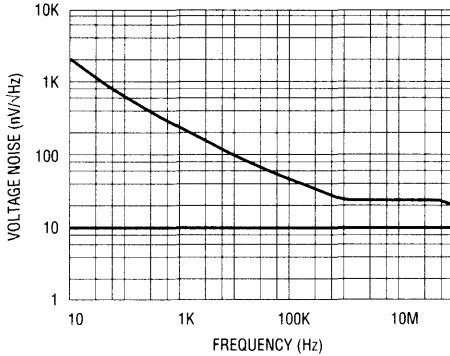

Closed Loop Output Impedance vs. Frequency
 $R_F = 0, A_V = +1$

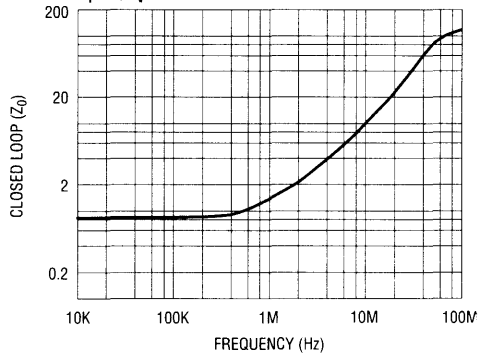

Offset Voltage vs. Die Temperature
(6 Typical Samples)

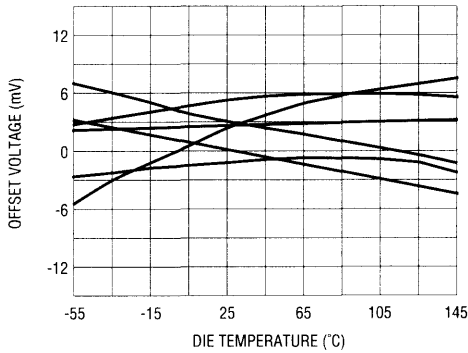

PSRR and CMRR vs. Frequency

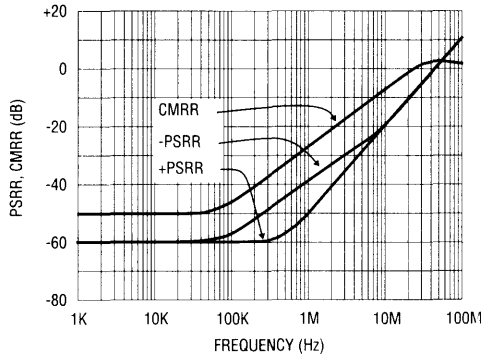

Output Voltage Swing vs. Frequency for THD < 1%
 $R_F = 1K\Omega, A_V = +2$

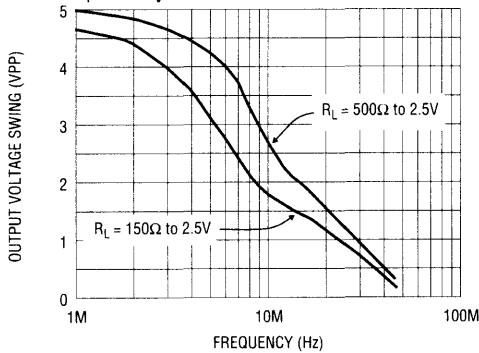

Output Voltage Swing vs. Frequency for THD < 0.1%
 $R_F = 1K\Omega, A_V = +2$

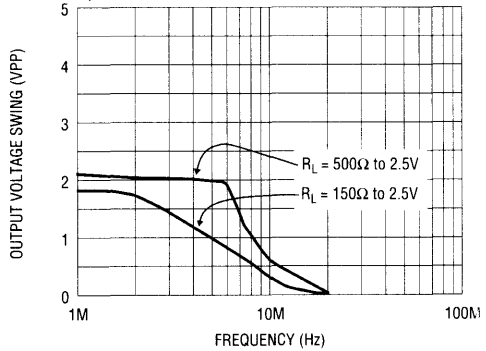

EL5144C, EL5146C, EL5244C, EL5246C, EL5444C

100MHz Single Supply Rail-to-Rail Amplifier

Typical Performance Curves

Large Signal Pulse Response (Single Supply)
 $V_S = +5V$, $R_L = 150\Omega$ to OV , $R_F = 1K\Omega$, $A_V = +2$

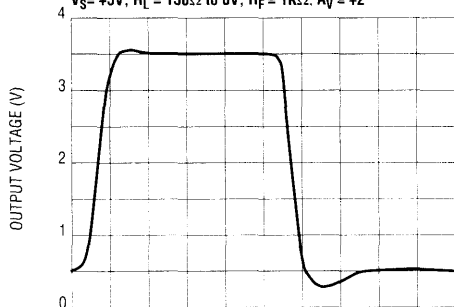

TIME (20ns/DIV)

Small Signal Pulse Response (Single Supply)
 $V_S = +5V$, $R_L = 150\Omega$ to OV , $R_F = 1K\Omega$, $A_V = +2$

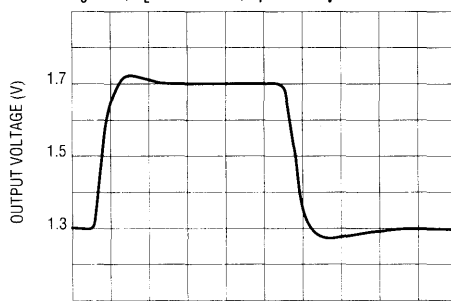

TIME (20ns/DIV)

Large Signal Pulse Response (Split Supplies)
 $V_S = \pm 2.5V$, $R_L = 150\Omega$ to OV , $R_F = 1K\Omega$, $A_V = +2$

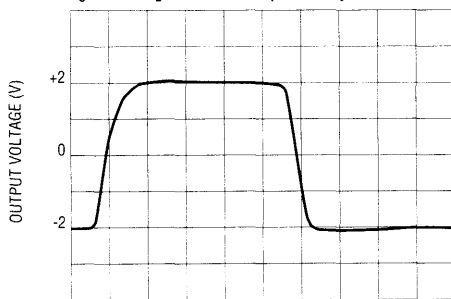

TIME (20ns/DIV)

Small Signal Pulse Response (Split Supply)
 $V_S = \pm 2.5V$, $R_L = 150\Omega$ to OV , $R_F = 1K\Omega$, $A_V = +2$

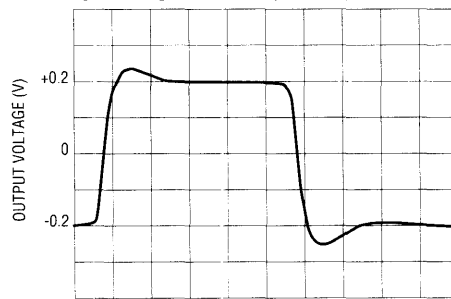

TIME (20ns/DIV)

Settling Time vs. Settling Accuracy
 $R_L = 1K\Omega$, $R_F = 500\Omega$, $A_V = -1$, $V_{STEP} = 3V$

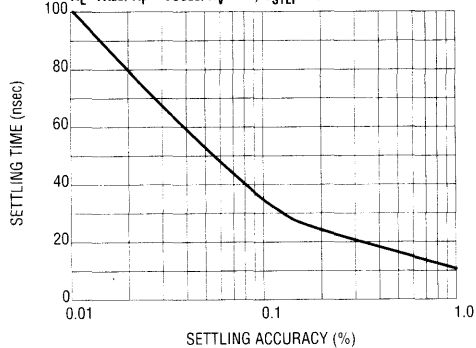

Slew Rate vs. Die Temperature

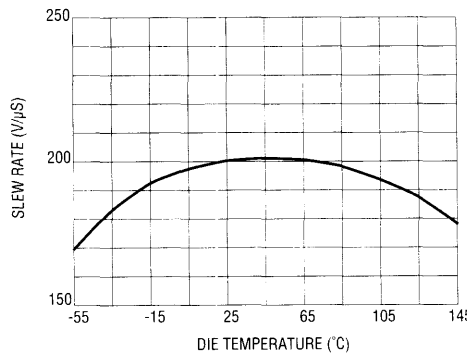

EL5144C, EL5146C, EL5244C, EL5246C, EL5444C

100MHz Single Supply Rail-to-Rail Amplifier

EL5144C, EL5146C, EL5244C, EL5246C, EL5444C

Amplifiers

Typical Performance Curves

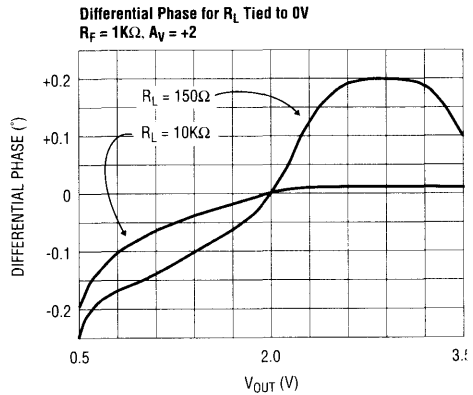
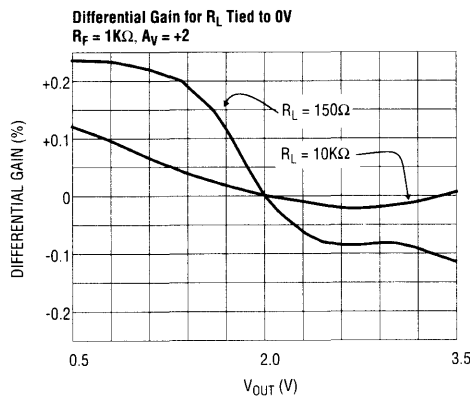
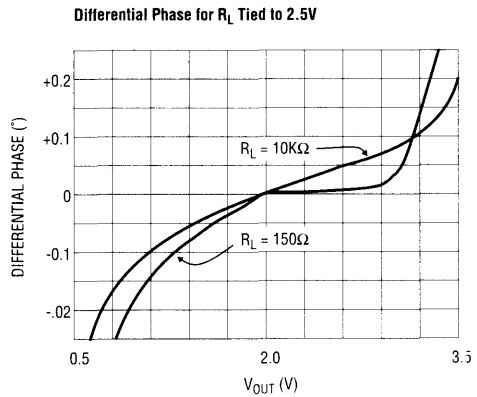
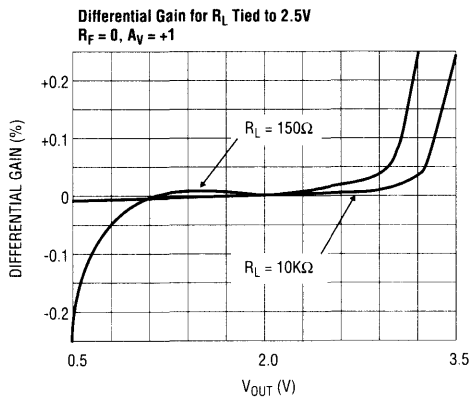
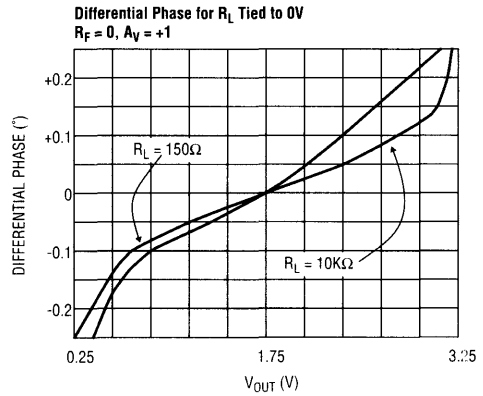
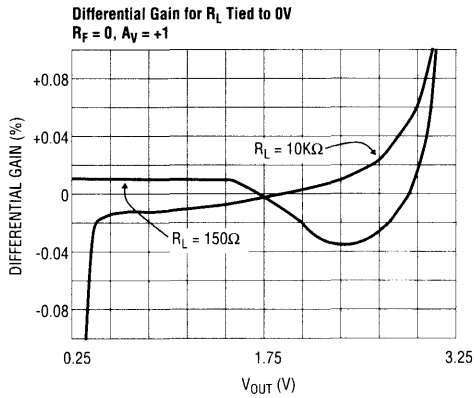

EL5144C, EL5146C, EL5244C, EL5246C, EL5444C

100MHz Single Supply Rail-to-Rail Amplifier

Typical Performance Curves

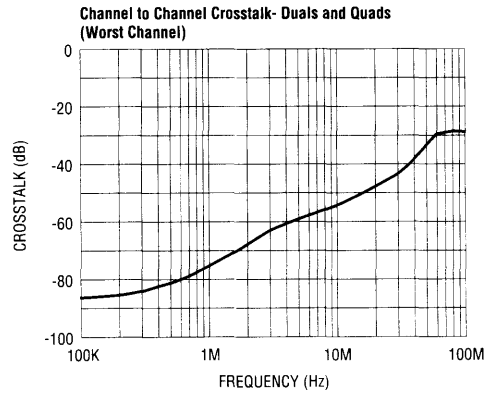
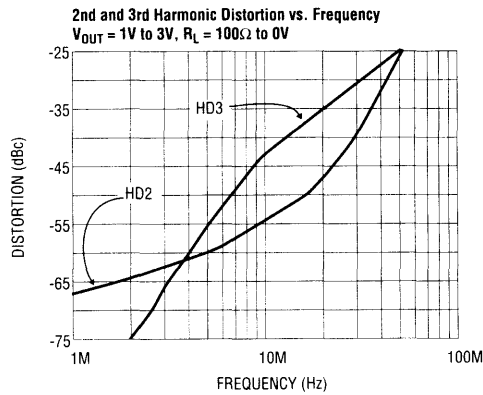
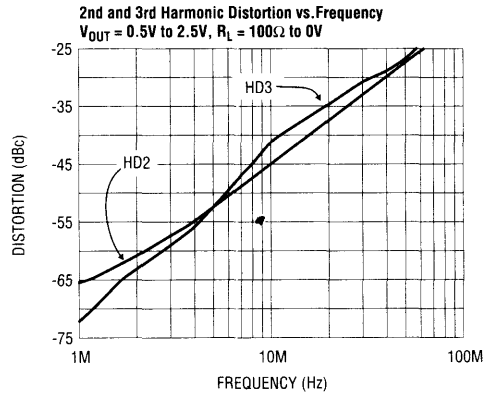
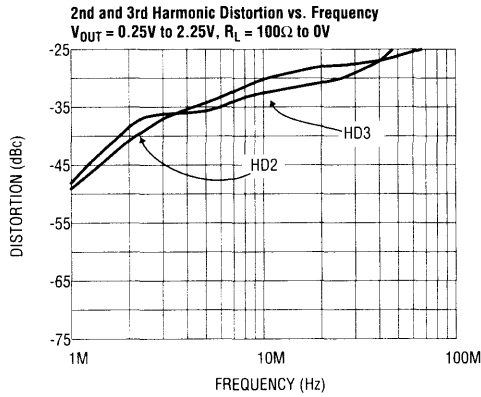
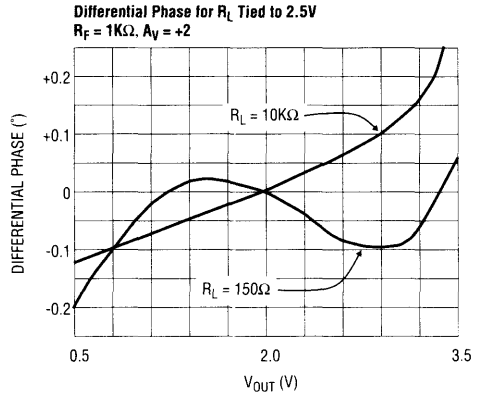
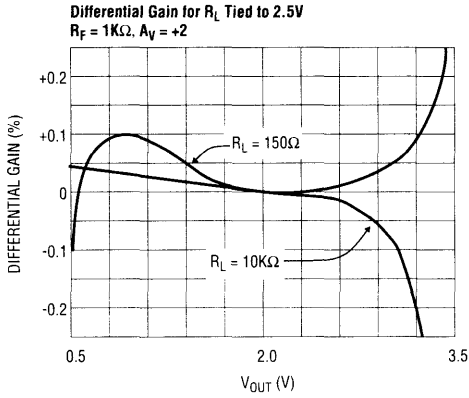

EL5144C, EL5146C, EL5244C, EL5246C, EL5444C

100MHz Single Supply Rail-to-Rail Amplifier

EL5144C, EL5146C, EL5244C, EL5246C, EL5444C

Amplifiers

Typical Performance Curves

Supply Current (per Amp) vs. Supply Voltage

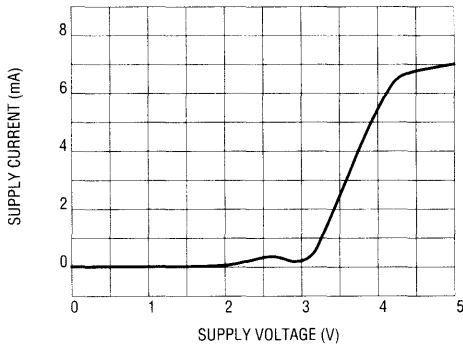

Output Current vs. Die Temperature
 $R_L = 10\Omega$ to 2.5V

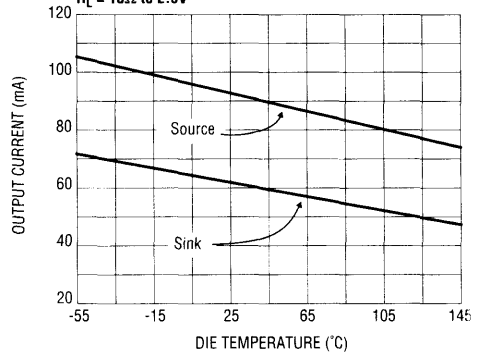

Supply Current - ON (per amp) vs. Die Temperature

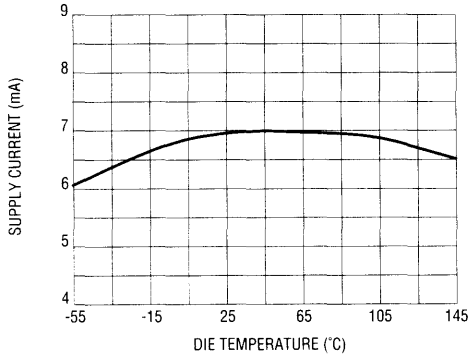

Supply Current - OFF (per amp) vs. Die Temperature

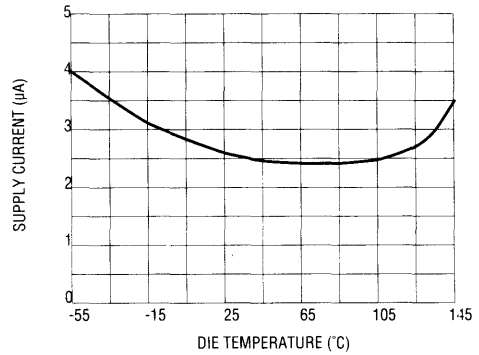

Positive Output Voltage Swing vs. Die Temperature
 $R_L = 150\Omega$

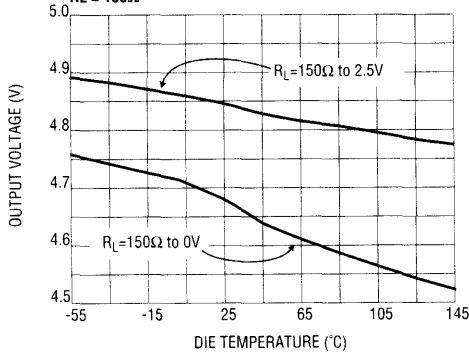

Negative Output Voltage Swing vs. Die Temperature

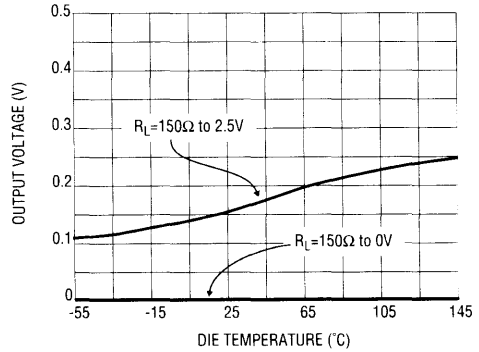

EL5144C, EL5146C, EL5244C, EL5246C, EL5444C

100MHz Single Supply Rail-to-Rail Amplifier

Typical Performance Curves

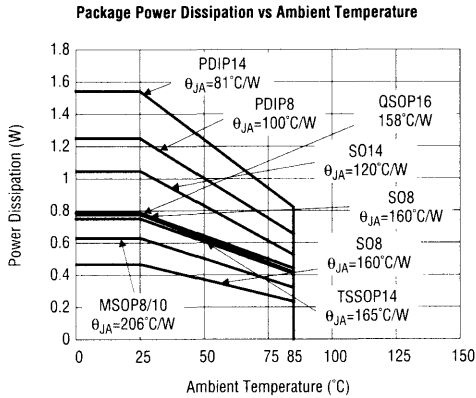
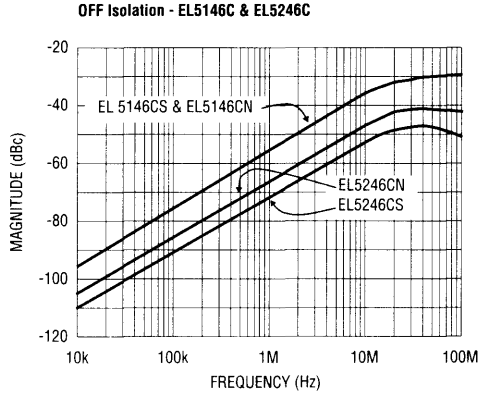
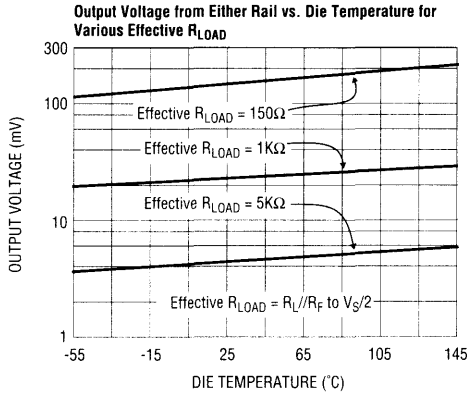

EL5144C, EL5146C, EL5244C, EL5246C, EL5444C

100MHz Single Supply Rail-to-Rail Amplifier

EL5144C, EL5146C, EL5244C, EL5246C, EL5444C

Amplifiers

Pin Descriptions

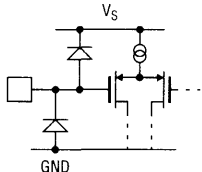
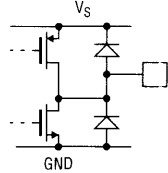
EL5144C (SOT23)	EL5146C (SO/PDIP)	EL5244C (SO/PDIP/MSOP)	EL5246C (MSOP)	EL5246C (SO/PDIP)	EL5444C (SO/PDIP/TSSOP)	EL5444C (QSOP)	Name	Function	Equivalent Circuit	
5	7	8	8	11	4	4, 5	VS	Positive Power Supply		
2	4	4	3	4	11	12, 13	GND	Ground or Negative Power Supply		
3	3						IN+	Noninverting Input	 <p>Circuit 1</p>	
4	2						IN-	Inverting Input	(Reference Circuit 1)	
1	6						OUT	Amplifier Output	 <p>Circuit 2</p>	
		3	1	1	3	3	INA+	Amplifier A Noninverting Input	(Reference Circuit 1)	
		2	10	14	2	2	INA-	Amplifier A Inverting Input	(Reference Circuit 1)	
		1	9	13	1	1	OUTA	Amplifier A Output	(Reference Circuit 2)	
		5	5	7	5	6	INB+	Amplifier B Noninverting Input	(Reference Circuit 1)	
		6	6	8	6	7	INB-	Amplifier B Inverting Input	(Reference Circuit 1)	
		7	7	9	7	8	OUTB	Amplifier B Output	(Reference Circuit 2)	
						10	11	INC+	Amplifier C Noninverting Input	(Reference Circuit 1)
						9	10	INC-	Amplifier C Inverting Input	(Reference Circuit 1)
						8	9	OUTC	Amplifier C Output	(Reference Circuit 2)
						12	14	IND+	Amplifier D Noninverting Input	(Reference Circuit 1)
						13	15	IND-	Amplifier D Inverting Input	(Reference Circuit 1)
						14	16	OUTD	Amplifier D Output	(Reference Circuit 2)

EL5144C, EL5146C, EL5244C, EL5246C, EL5444C

100MHz Single Supply Rail-to-Rail Amplifier

Pin Descriptions

EL5144C (SOT23)	EL5146C (SO/PDIP)	EL5244C (SO/PDIP/MSOP)	EL5246C (MSOP)	EL5246C (SO/PDIP)	EL5444C (SO/PDIP/TSSOP)	EL5444C (QSOP)	Name	Function	Equivalent Circuit
	8						CE	Enable (Enabled when high)	<p style="text-align: center;">Circuit 3</p>
			2	3			CEA	Enable Amplifier A (Enabled when high)	(Reference Circuit 3)
			4	5			CEB	Enable Amplifier B (Enabled when high)	(Reference Circuit 3)
	1, 5			2, 6, 10, 12			NC	No Connect. Not internally connected.	

EL5144C, EL5146C, EL5244C, EL5246C, EL5444C

100MHz Single Supply Rail-to-Rail Amplifier

EL5144C, EL5146C, EL5244C, EL5246C, EL5444C

Amplifiers

Description of Operation and Applications Information

Product Description

The EL5144C series is a family of wide bandwidth, single supply, low power, rail-to-rail output, voltage feedback operational amplifiers. The family includes single, dual, and quad configurations. The singles and duals are available with a power down pin to reduce power to 2.6 μ A typically. All the amplifiers are internally compensated for closed loop feedback gains of +1 or greater. Larger gains are acceptable but bandwidth will be reduced according to the familiar Gain-Bandwidth Product.

Connected in voltage follower mode and driving a high impedance load, the EL5144C series has a -3dB bandwidth of 100 MHz. Driving a 150 Ω load, they have a -3dB bandwidth of 60MHz while maintaining a 200V/ μ s slew rate. The input common mode voltage range includes ground while the output can swing rail to rail.

Power Supply Bypassing and Printed Circuit Board Layout

As with any high-frequency device, good printed circuit board layout is necessary for optimum performance. Ground plane construction is highly recommended. Lead lengths should be as short as possible. The power supply pin must be well bypassed to reduce the risk of oscillation. For normal single supply operation, where the GND pin is connected to the ground plane, a single 4.7 μ F tantalum capacitor in parallel with a 0.1 μ F ceramic capacitor from VS to GND will suffice. This same capacitor combination should be placed at each supply pin to ground if split supplies are to be used. In this case, the GND pin becomes the negative supply rail.

For good AC performance, parasitic capacitance should be kept to a minimum. Use of wire wound resistors should be avoided because of their additional series inductance. Use of sockets, particularly for the SO package, should be avoided if possible. Sockets add parasitic inductance and capacitance that can result in compromised performance.

Input, Output, and Supply Voltage Range

The EL5144C series has been designed to operate with a single supply voltage of 5V. Split supplies can be used so long as their total range is 5V.

The amplifiers have an input common mode voltage range that includes the negative supply (GND pin) and extends to within 1.5V of the positive supply (VS pin). They are specified over this range.

The output of the EL5144C series amplifiers can swing rail to rail. As the load resistance becomes lower in value, the ability to drive close to each rail is reduced. However, even with an effective 150 Ω load resistor connected to a voltage halfway between the supply rails, the output will swing to within 150mV of either rail.

Figure 1 shows the output of the EL5144C series amplifier swinging rail to rail with $R_F = 1k\Omega$, $A_V = +2$ and $R_L = 1M\Omega$. Figure 2 is with $R_L = 150\Omega$.

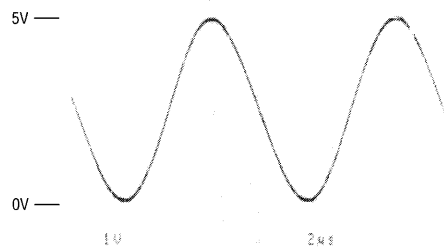

Figure 1

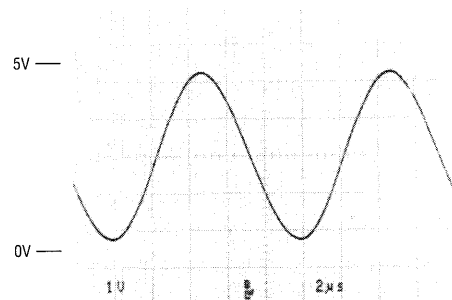

Figure 2

EL5144C, EL5146C, EL5244C, EL5246C, EL5444C**100MHz Single Supply Rail-to-Rail Amplifier****Choice of Feedback Resistor, R_F**

These amplifiers are optimized for applications that require a gain of +1. Hence, no feedback resistor is required. However, for gains greater than +1, the feedback resistor forms a pole with the input capacitance. As this pole becomes larger, phase margin is reduced. This causes ringing in the time domain and peaking in the frequency domain. Therefore, R_F has some maximum value that should not be exceeded for optimum performance. If a large value of R_F must be used, a small capacitor in the few picofarad range in parallel with R_F can help to reduce this ringing and peaking at the expense of reducing the bandwidth.

As far as the output stage of the amplifier is concerned, $R_F + R_G$ appear in parallel with R_L for gains other than +1. As this combination gets smaller, the bandwidth falls off. Consequently, R_F also has a minimum value that should not be exceeded for optimum performance.

For $A_V = +1$, $R_F = 0\Omega$ is optimum. For $A_V = -1$ or +2 (noise gain of 2), optimum response is obtained with R_F between 300 Ω and 1k Ω . For $A_V = -4$ or +5 (noise gain of 5), keep R_F between 300 Ω and 15k Ω .

Video Performance

For good video signal integrity, an amplifier is required to maintain the same output impedance and the same frequency response as DC levels are changed at the output. This can be difficult when driving a standard video load of 150 Ω , because of the change in output current with DC level. A look at the Differential Gain and Differential Phase curves for various supply and loading conditions will help you obtain optimal performance. Curves are provided for $A_V = +1$ and +2, and $R_L = 150\Omega$ and 10k Ω tied both to ground as well as 2.5V. As with all video amplifiers, there is a common mode sweet spot for optimum differential gain/differential phase. For example, with $A_V = +2$ and $R_L = 150\Omega$ tied to 2.5V, and the output common mode voltage kept between 0.8V and 3.2V, dG/dP is a very low 0.1%/0.1°. This condition corresponds to driving an AC-coupled, double terminated 75 Ω coaxial cable. With $A_V = +1$, $R_L = 150\Omega$ tied to ground, and the video level kept between 0.85V and 2.95V, these amplifiers provide dG/dP performance of 0.05%/0.20°. This condition is representative of using

the EL5144C series amplifier as a buffer driving a DC coupled, double terminated, 75 Ω coaxial cable. Driving high impedance loads, such as signals on computer video cards, gives similar or better dG/dP performance as driving cables.

Driving Cables and Capacitive Loads

The EL5144C series amplifiers can drive 50pF loads in parallel with 150 Ω with 4dB of peaking and 100pF with 7dB of peaking. If less peaking is desired in these applications, a small series resistor (usually between 5 Ω and 50 Ω) can be placed in series with the output to eliminate most peaking. However, this will obviously reduce the gain slightly. If your gain is greater than 1, the gain resistor (R_G) can then be chosen to make up for any gain loss which may be created by this additional resistor at the output. Another method of reducing peaking is to add a "snubber" circuit at the output. A snubber is a resistor in a series with a capacitor, 150 Ω and 100pF being typical values. The advantage of a snubber is that it does not draw DC load current.

When used as a cable driver, double termination is always recommended for reflection-free performance. For those applications, the back-termination series resistor will de-couple the EL5144C series amplifier from the cable and allow extensive capacitive drive. However, other applications may have high capacitive loads without a back-termination resistor. Again, a small series resistor at the output can reduce peaking.

Disable/Power-Down

The EL5146C and EL5246C amplifiers can be disabled, placing its output in a high-impedance state. Turn off time is only 10 nsec and turn on time is around 500ns. When disabled, the amplifier's supply current is reduced to 2.6 μ A typically, thereby effectively eliminating power consumption. The amplifier's power down can be controlled by standard TTL or CMOS signal levels at the CE pin. The applied logic signal is relative to the GND pin. Letting the CE pin float will enable the amplifier. Hence, the 8 pin PDIP and SO single amps are pin compatible with standard amplifiers that don't have a power down feature.

EL5144C, EL5146C, EL5244C, EL5246C, EL5444C

100MHz Single Supply Rail-to-Rail Amplifier

EL5144C, EL5146C, EL5244C, EL5246C, EL5444C

Amplifiers

Short Circuit Current Limit

The EL5144C series amplifiers do not have internal short circuit protection circuitry. Short circuit current of 90mA sourcing and 65mA sinking typically will flow if the output is trying to drive high or low but is shorted to half way between the rails. If an output is shorted indefinitely, the power dissipation could easily increase such that the part will be destroyed. Maximum reliability is maintained if the output current never exceeds $\pm 50\text{mA}$. This limit is set by internal metal interconnect limitations. Obviously, short circuit conditions must not remain or the internal metal connections will be destroyed.

Power Dissipation

With the high output drive capability of the EL5144C series amplifiers, it is possible to exceed the 150°C Absolute Maximum junction temperature under certain load current conditions. Therefore, it is important to calculate the maximum junction temperature for the application to determine if load conditions or package type need to be modified for the amplifier to remain in the safe operating area.

The maximum power dissipation allowed in a package is determined according to:

$$PD_{MAX} = \frac{T_{JMAX} - T_{AMAX}}{\theta_{JA}}$$

Where:

- T_{JMAX} = Maximum Junction Temperature
- T_{AMAX} = Maximum Ambient Temperature
- θ_{JA} = Thermal Resistance of the Package
- PD_{MAX} = Maximum Power Dissipation in the Package.

The maximum power dissipation actually produced by an IC is the total quiescent supply current times the total power supply voltage, plus the power in the IC due to the load, or:

$$PD_{MAX} = N \times \left[V_S \times I_{SMAX} + (V_S - V_{OUT}) \times \frac{V_{OUT}}{R_L} \right]$$

Where:

- N = Number of amplifiers in the package
- V_S = Total Supply Voltage
- I_{SMAX} = Maximum Supply Current Per Amplifier
- V_{OUT} = Maximum Output Voltage of the Application
- R_L = Load Resistance tied to Ground

If we set the two PD_{MAX} equations equal to each other, we can solve for R_L :

$$R_L = \frac{V_{OUT} \times (V_S - V_{OUT})}{\left(\frac{T_{JMAX} - T_{AMAX}}{N \times \theta_{JA}} \right) - (V_S \times I_{SMAX})}$$

Assuming worst case conditions of $T_A = +85^\circ\text{C}$, $V_{OUT} = V_S/2V$, $V_S = 5.5V$, and $I_{SMAX} = 8.8\text{mA}$ per amplifier, below is a table of all packages and the minimum R_L allowed.

Part	Package	Minimum R_L
EL5144CW	5-Pin SOT23	37
EL5146CS	8-Pin SO	21
EL5146CN	8-Pin PDIP	14
EL5244CS	8-Pin SO	48
EL5244CN	8-Pin PDIP	30
EL5244CY	8-Pin MSOP	69
EL5246CY	10-Pin MSOP	69
EL5246CS	14-Pin SO	34
EL5246CN	14-Pin PDIP	23
EL5444CU	16-Pin QSOP	139
EL5444CS	14-Pin SO	85
EL5444CN	14-Pin PDIP	51
EL5444CR	14-Pin TSSOP	

EL5144C Series Comparator Application

The EL5144C series amplifier can be used as a very fast, single supply comparator. Most op amps used as a comparator allow only slow speed operation because of output saturation issues. The EL5144C series amplifier doesn't suffer from output saturation issues. Figure 3 shows the amplifier implemented as a comparator. Fig-

EL5144C, EL5146C, EL5244C, EL5246C, EL5444C

100MHz Single Supply Rail-to-Rail Amplifier

Figure 4 is a graph of propagation delay vs. overdrive as a square wave is presented at the input of the comparator.

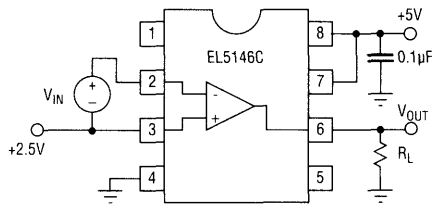

Figure 3

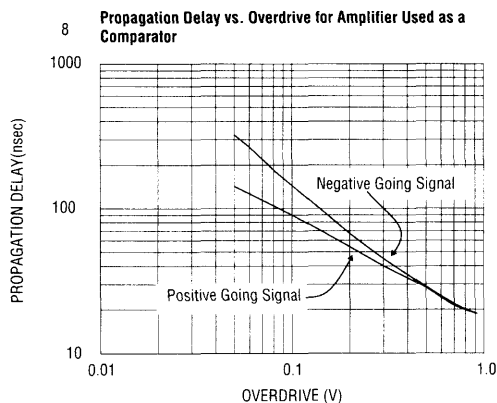

Figure 4

Multiplexing with the EL5144C Series Amplifier

Besides normal power down usage, the CE (Chip Enable) pin on the EL5146C and EL5246C series amplifiers also allow for multiplexing applications. Figure 5 shows an EL5246C with its outputs tied together, driving a back terminated 75Ω video load. A 3V_{p-p} 10MHz sine wave is applied at Amp A input, and a 2.4V_{p-p} 5MHz square wave to Amp B. Figure 6 shows the SELECT signal that is applied, and the resulting output waveform at V_{OUT}. Observe the break-before-make operation of the multiplexing. Amp A is on and V_{IN1} is being passed through to the output of the amplifier. Then Amp A turns off in about 10ns. The output decays to ground with an R_LC_L time constants. 500ns later, Amp B turns on and V_{IN2} is passed through to the output. This

break-before-make operation ensures that more than one amplifier isn't trying to drive the bus at the same time. Notice the outputs are tied directly together. Isolation resistors at each output are not necessary.

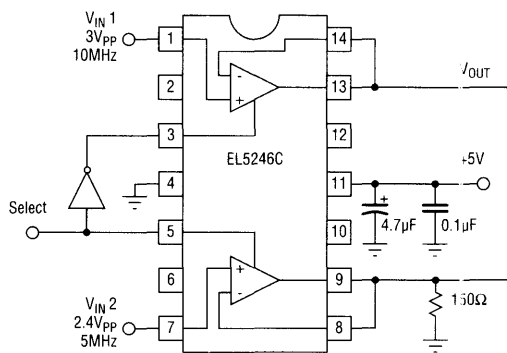

Figure 5

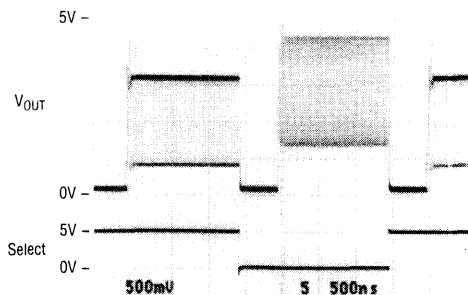

Figure 6

Free Running Oscillator Application

Figure 7 is an EL5144C configured as a free running oscillator. To first order, R_{OSC} and C_{OSC} determine the frequency of oscillation according to:

$$F_{osc} = \frac{0.72}{R_{osc} \times C_{osc}}$$

For rail to rail output swings, maximum frequency of oscillation is around 15MHz. If reduced output swings are acceptable, 25MHz can be achieved. Figure 8 shows

EL5144C, EL5146C, EL5244C, EL5246C, EL5444C

100MHz Single Supply Rail-to-Rail Amplifier

EL5144C, EL5146C, EL5244C, EL5246C, EL5444C

Amplifiers

the oscillator for $R_{OSC} = 510\Omega$, $C_{OSC} = 240\text{pF}$ and $F_{OSC} = 6\text{MHz}$.

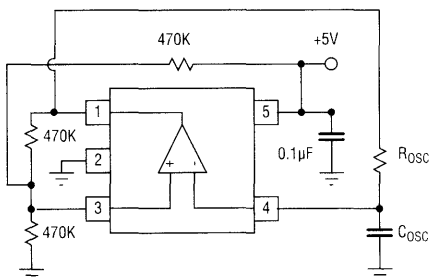

Figure 7

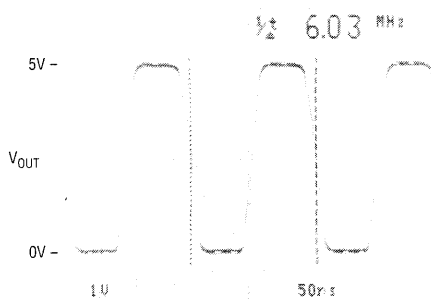

Figure 8