

REVISIONS				
P	LTN	DESCRIPTION	DATE	APVD
A4		ECR-21-123293	2FEB2022	RK JB

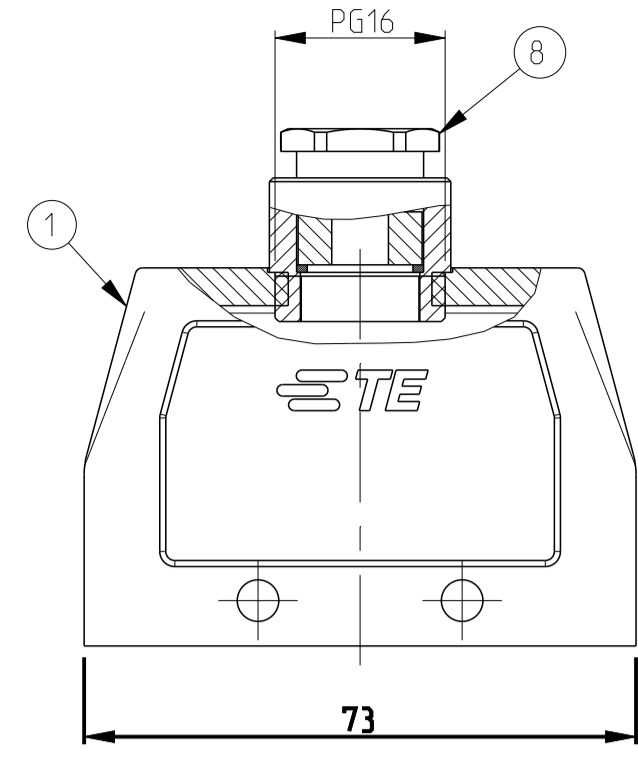

PN 4-6

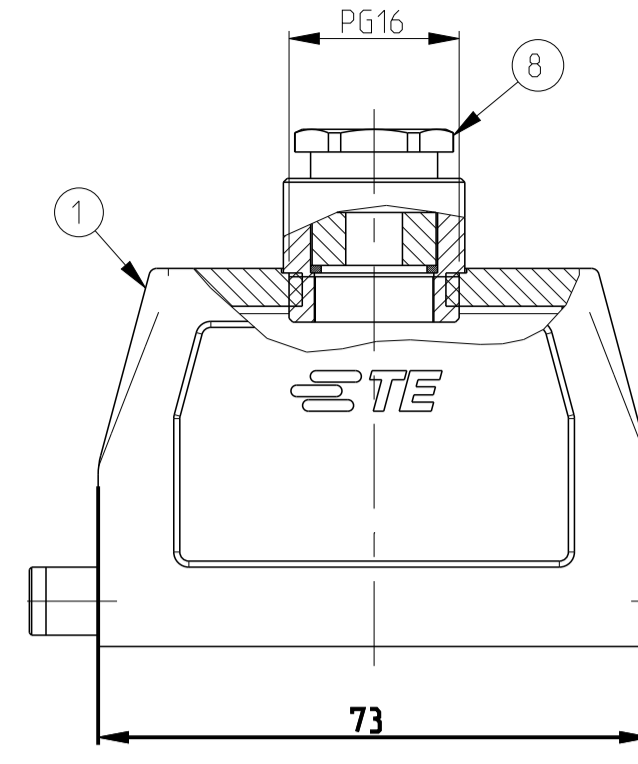
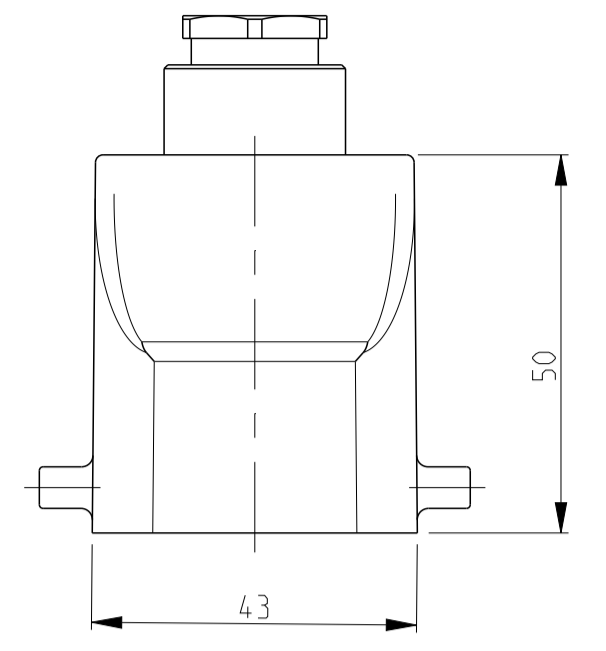

PN 1-7

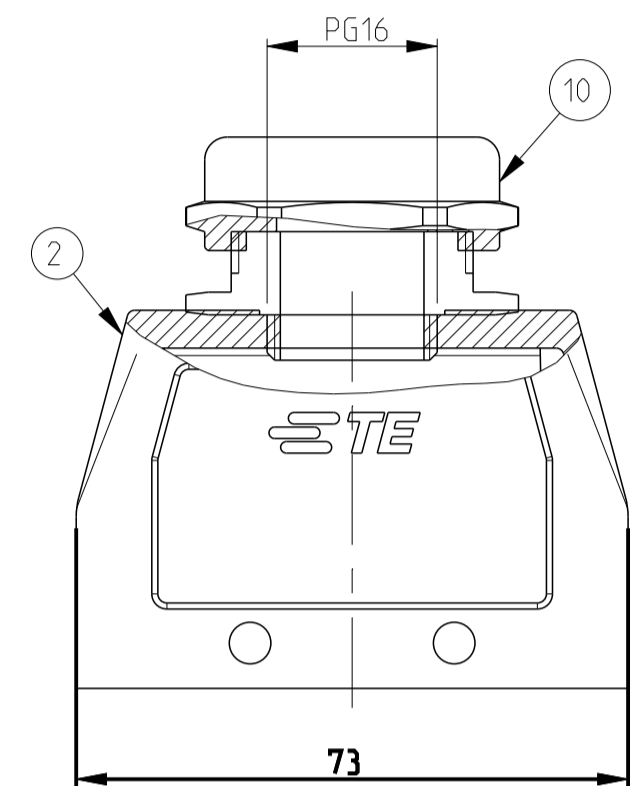
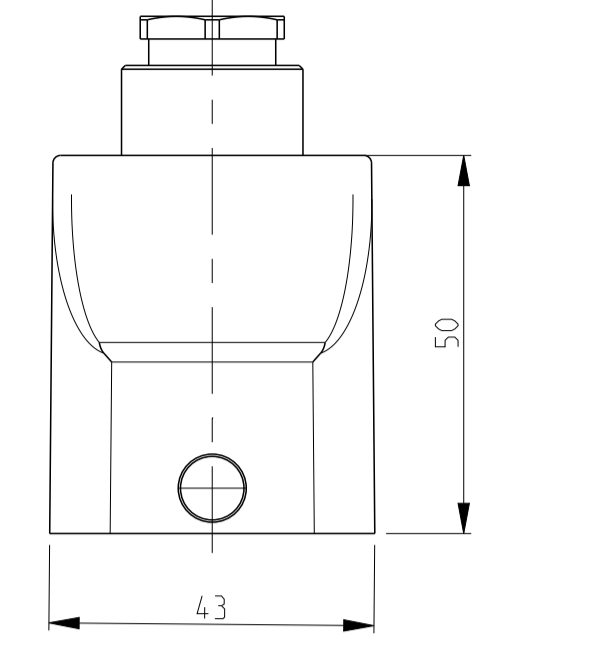

PN 2-6

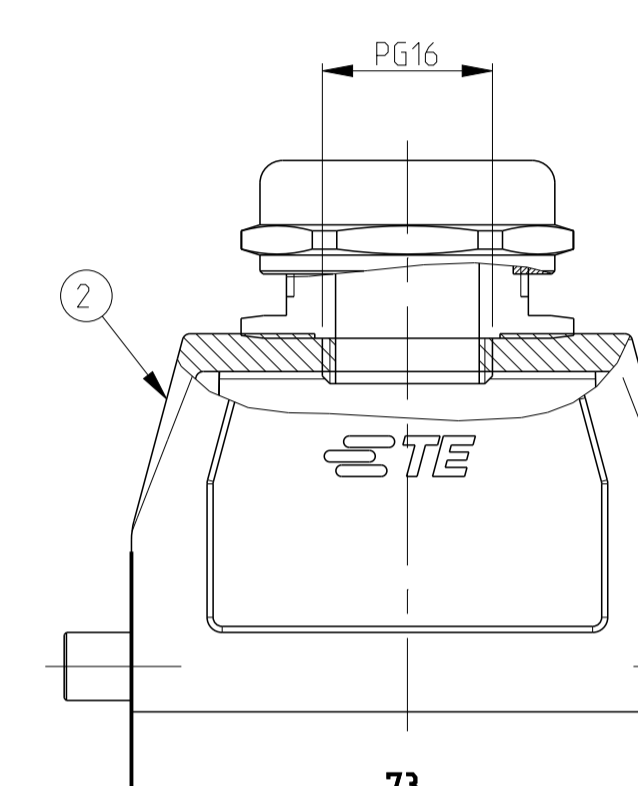
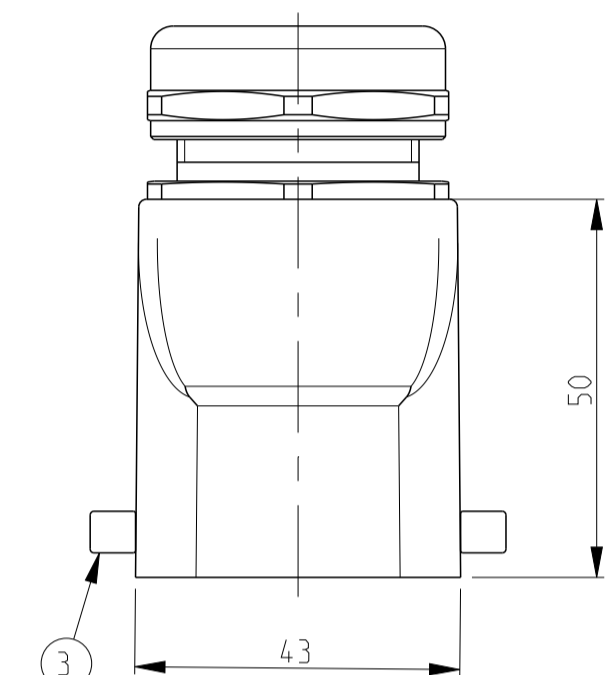

PN 2-7

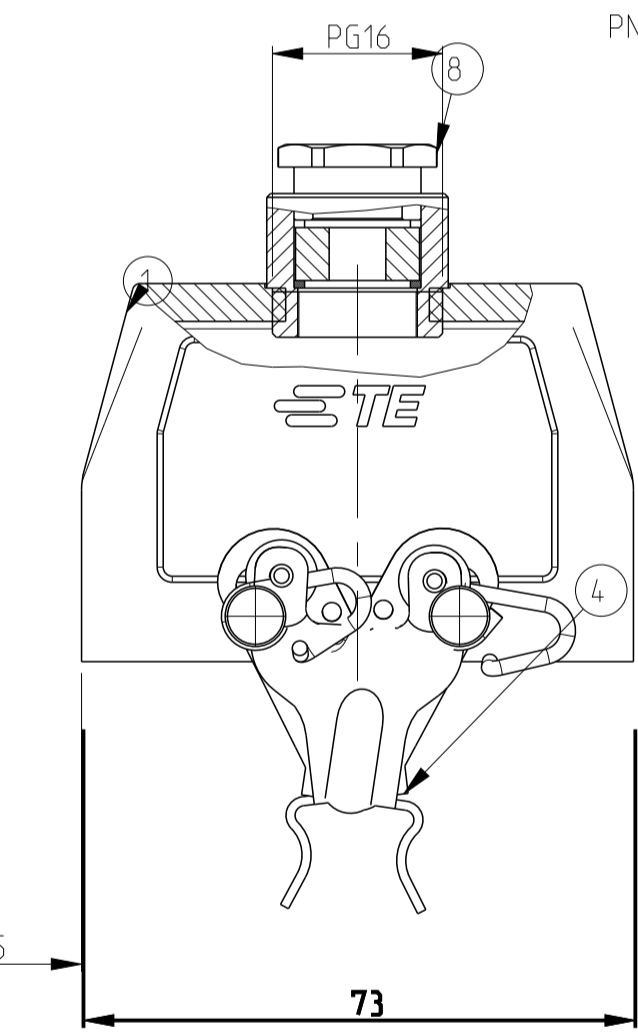
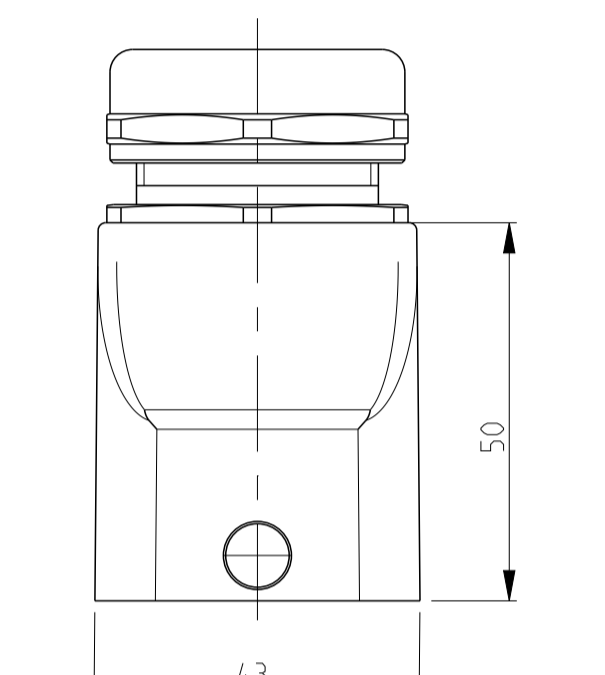

PN 1-1

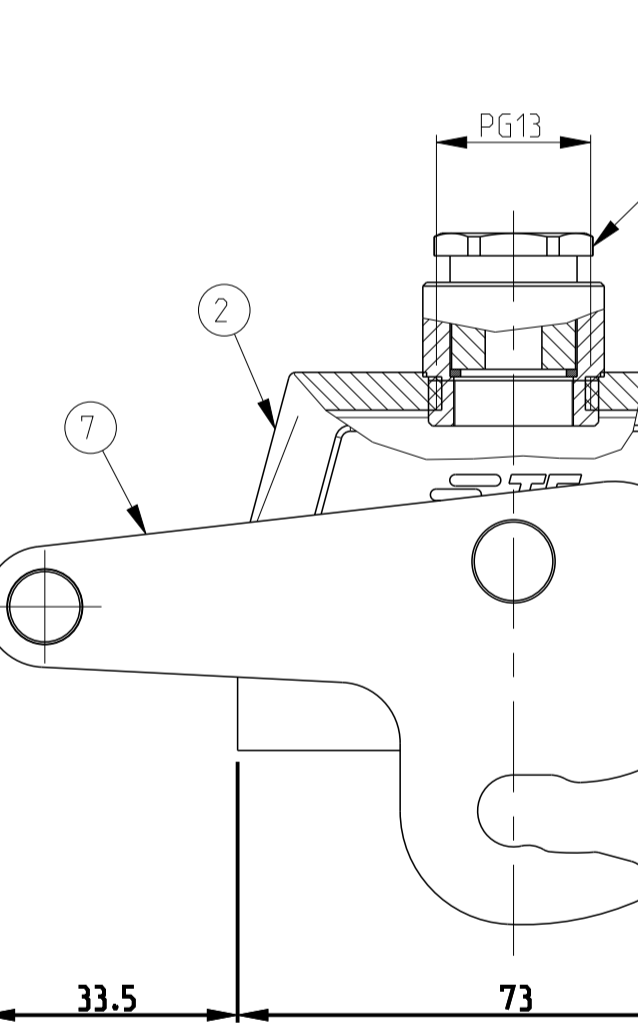
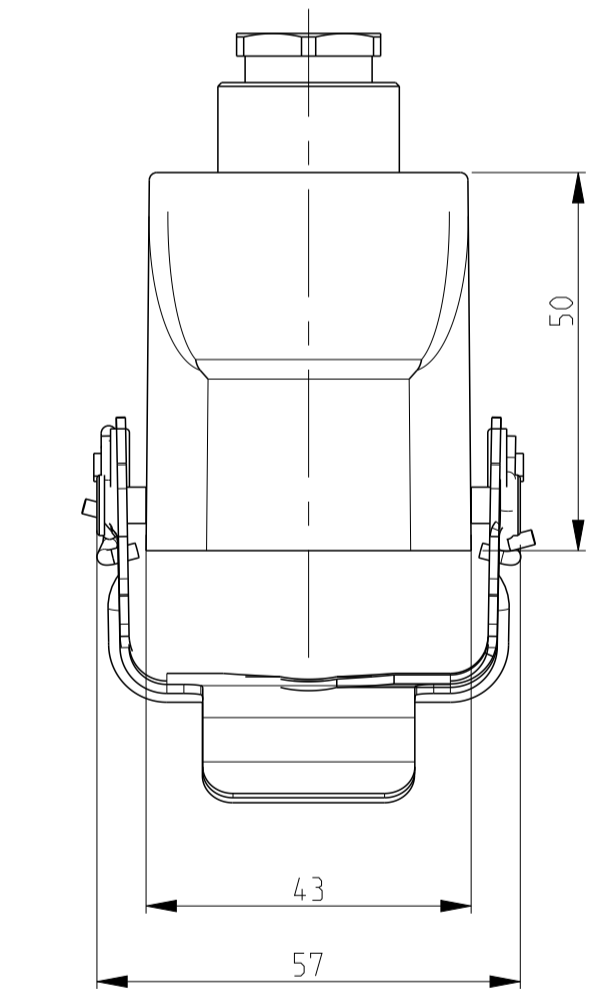

PN 1-3

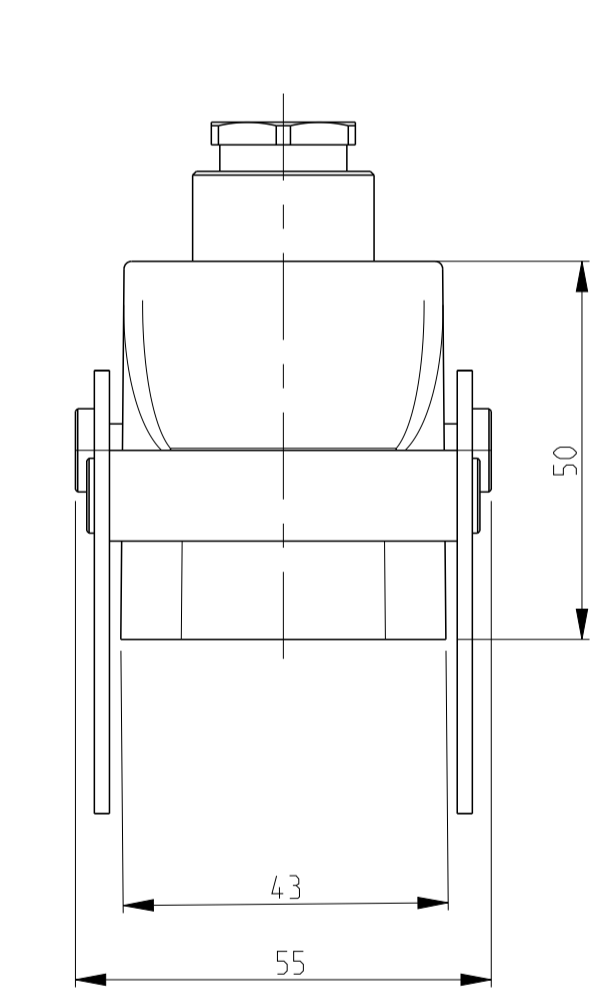

NOTES.

- 1 Material:Housing:Aluminium Diecasting Alloy
- 2 Surface-Powder Varnish Grey
-Aluminium Oxide +
Varnish Black
- 3 Varnish on the inside not necessary
- 4 Packaging
Quantity 5 Pieces in a box
- 5 OBSOLETE PARTS: OBSOLETE CIS STREAMLINING PER
D.RENAUD/D.SINISI

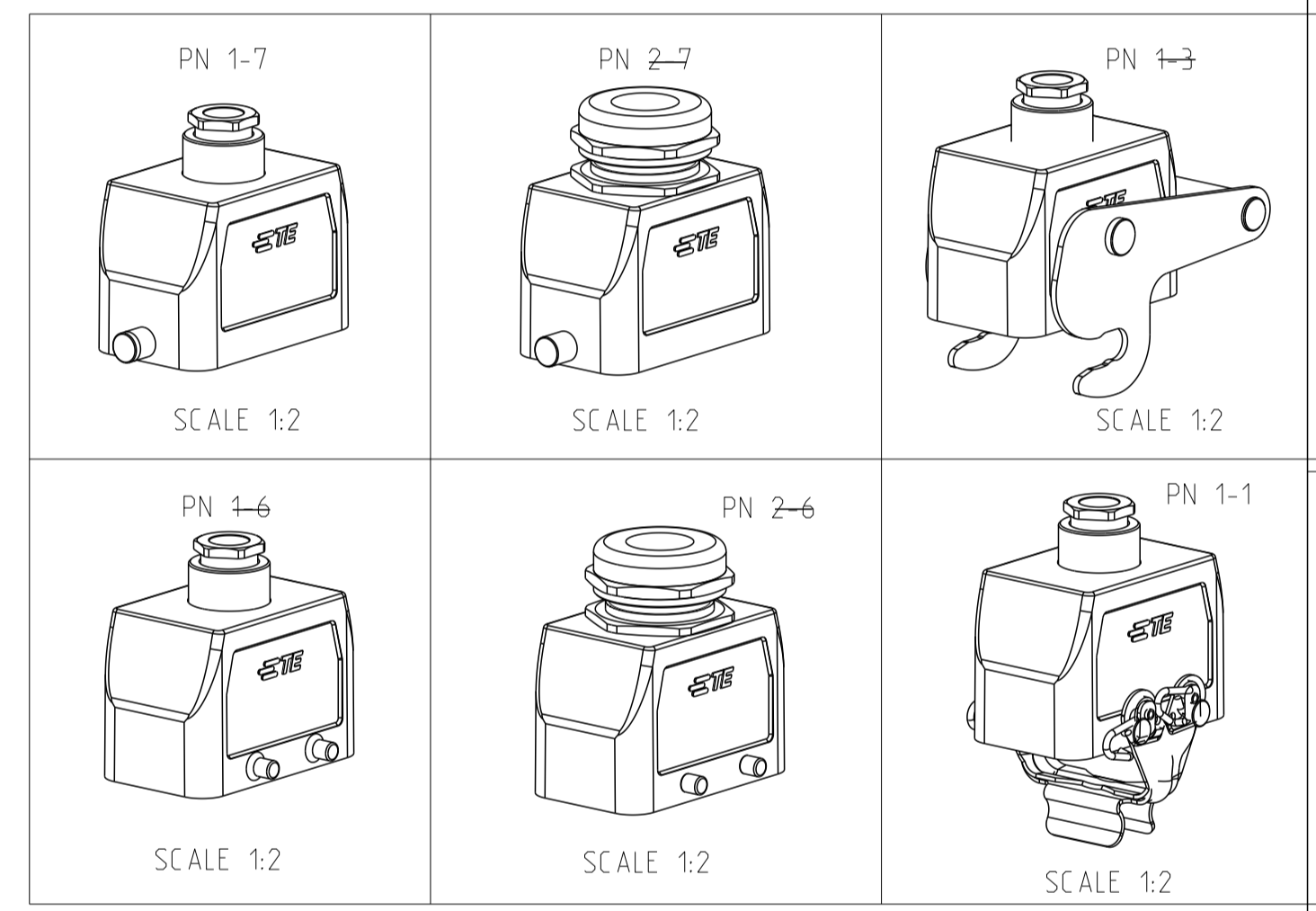

QTY	DESCRIPTION	MATERIAL	SURFACE	COLOR	ITEM NO	NOTES
1	Gland fitting PG16	Brass	Nickel plated		10	
1	Label connection round PG13	Brass	Nickel plated		9	
1	Label connection round PG16	Brass	Nickel plated		8	
1	ZB-Central clip	Steel	Zinc plated		7	
2	LB-Clip bolt	Stainless steel	-		6	
2	LB-Clip bolt	Steel	Zinc plated		5	
2	VS-Side clip	Steel	Zinc plated		4	
4	VS-Clip bolt	Stainless steel	-		3	
1	Hood HB.10.Pg1.16	Aluminium	Aluminium oxide	Black	2	
1	Hood HB.10.Pg1.16	Aluminium	-	Grey	1	
1-32-71-71-12-61-6	DESCRIPTION	MATERIAL	SURFACE	COLOR	ITEM NO	NOTES
ORDERING TEXT						

THIS DRAWING IS A CONTROLLED DOCUMENT.

DWG: Schneider 06.06.01
CHK: Schwiiger 06.06.01

TE Connectivity

NAME: Hood HB.10.STO.1.16

SIZE: A | 00779 | C=1102265

SCALE: 1:1 SHEET 1 OF 1 REV: A4

CUSTOMER DRAWING