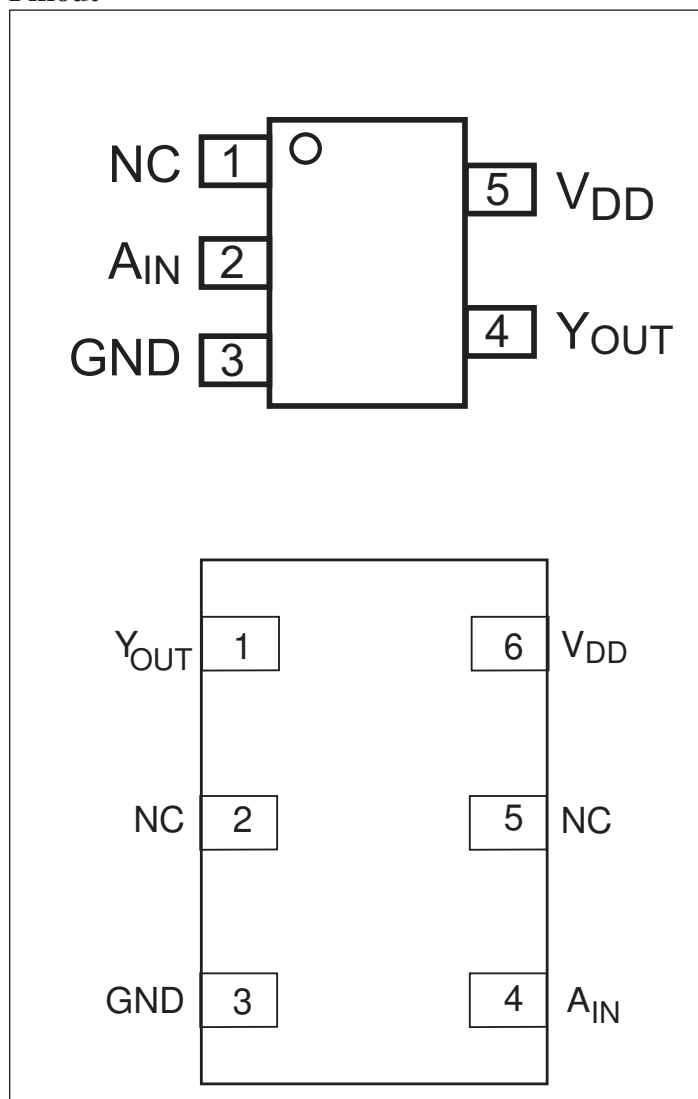
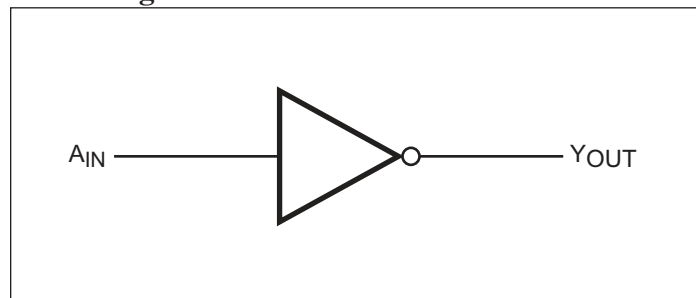

Features

- High-speed: $t_{PD} = 2.6\text{ns}$ typical into 50pF @ 5V VDD
- Unbuffered Output
- Broad operating range: $V_{DD} = 1.65\text{V} - 5.5\text{V}$
- Power down high-impedance inputs/outputs
- Balanced output drive: $\pm 8\text{mA}$ at 3V VDD
- Packaging (Pb-free & Green available):
 - 5-pin SOT23(T)
 - 5-pin SC70(C)
 - 6-pin UDFN(ZR)

Description

The PI74STX1GU04 is an unbuffered inverter that operates over the 1.65V to 5.5V VDD operating range.

Pinout

Pin Configuration

Recommended Operating Conditions

Parameter	Condition	Min.	Max.	Units
Supply Voltage (V_{DD})		1.65	5.5	V
Input Voltage (V_{IN})		0	5.5	
Output Voltage (V_{OUT})		0	V_{DD}	
Operating Temperature		-40	85	°C
Input Rise and Fall Time (t_r, t_f)	$V_{DD} = 1.8\text{V}, 2.5\text{V} \pm 0.2\text{V}$	0	20	ns/V
	$V_{DD} = 3.3\text{V}, \pm 0.3\text{V}$	0	10	
	$V_{DD} = 5.0\text{V}, \pm 0.5\text{V}$	0	5	

Notes:

1. Unused inputs must be held HIGH or LOW. They may not float.

Pin Description

Pin Names	Description
A _{IN}	Input
Y _{OUT}	Output

Function Table

Input	Output
A _{IN}	Y _{OUT}
L	H
H	L

Notes:

H = HIGH Logic Level

L = LOW Logic Level

Absolute Maximum Ratings

Supply Voltage (VDD)	-0.5V to +6V
DC Input Voltage (V _{IN}).....	-0.5V to +6V
DC Output Voltage (V _{OUT}).....	-0.5V to +6V
DC Input Diode Current (I _{IK})	-50mA to 20mA
DC Output Diode Current (I _{OK})	-50mA to 20mA
DC Output Current (I _{OUT})	±50mA
DC VCC/GND Current (I _{CC} /I _{GND})	±50mA
Storage Temperature (T _{STG}).....	-65°C to +150°C
Junction Lead Temperature (I _{OS}).....	200°C
Power Dissipation SOT23.....	200mW
SC70.....	150mW

Note:

Absolute maximum ratings are DC values beyond which the device may be damaged or have its useful life impaired. The datasheet specifications should be met, without exception, to ensure that the system design is reliable over its power supply, temperature, and output/input loading variables. Pericom does not recommend operation outside datasheet specifications.

DC Electrical Characteristics

Symbol	Parameter	VDD (V)	Description		T _A = +25°C			T _A = -40 to +85°C		Units	
					Min.	Typ	Max.	Min.	Max.		
V _{IH}	HIGH Level Input Voltage	1.8-2.7 3.0-5.5			0.85 V _{DD} 0.8 V _{DD}			0.85 V _{DD} 0.8 V _{DD}		V	
V _{IL}	LOW Level Input Voltage	1.8-2.7 3.0-5.5					0.15 V _{DD} 0.2 V _{DD}		0.15 V _{DD} 0.2 V _{DD}		
V _{OH}	HIGH Level Output Voltage	1.65	V _{IN} = V _{IL}	I _{OH} = -100μA	1.55	1.65		1.55			
		1.8			1,6	1.8		1,6			
		2.3			2.1	2.3		2.1			
		3.0			2.7	3.0		2.7			
		4.5			4.0	4.4		4.0			
			1.65		I _{OH} = -4mA	1.29	1.42		1.29		
			2.3			I _{OH} = -4mA	1.9	2.14		1.9	
			3.0			I _{OH} = -8mA	2.4	2.75		2.4	
			3.0			I _{OH} = -12mA	2.3	2.61		2.3	
			4.5			I _{OH} = -16mA	3.8	4.07		3.8	
V _{OL}	LOW Level Output Voltage	1.65	V _{IN} = V _{IH}	I _{OH} = 100μA		0.00	0.1		0.1		
		1.8			0.00	0.1		0.1			
		2.3			0.00	0.1		0.1			
		3.0			0.00	0.1		0.1			
		4.5			0.00	0.1		0.1			
			1.65		I _{OH} = 4mA		0.08	0.24		0.24	
			2.3			I _{OH} = 4mA	0.10	0.3		0.3	
			3.0			I _{OH} = 8mA	0.48	0.4		0.4	
			3.0			I _{OH} = 12mA	0.28	0.55		0.55	
			4.5			I _{OH} = 16mA	0.31	0.55		0.55	
I _{IN}	Input Leakage Current	0 to 5.5	V _{IN} = 5.5V, GND				±1		±10	μA	
IOFF	Power Off Leakage Current	0.0	V _{IN} or V _{OUT} = 5.5V		-1		1	-1	1		
ICC	Quiescent Supply Current	1.65 - 5.5	V _{IN} = 5.5V, GND				2.0		20		

AC Electrical Characteristics

Sym- bol	Parameter	VCC (V)	Conditions	TA = +25°C			TA = -25°C to +85°C		Units	Fig. No.
				Min.	Typ.	Max.	Min.	Max.		
t _{PLH} t _{PHL}	Propagation Delay	1.8 ± 0.15 2.5 ± 0.2 3.3 ± 0.3 5.0 ± 0.5	C _L = 15pF, R _L = 1M-ohm	0.7 0.5 0.5 0.5	5.0 3.0 2.3 1.8	6.3 3.7 3.0 2.4	0.7 0.5 0.5 0.5	6.9 4.1 3.3 2.6	ns	1 3
t _{PLH} t _{PHL}	Propagation Delay	3.3 ± 0.3 5.0 ± 0.5	C _L = 50pF, R _L = 500-ohm	0.5 0.5	3.2 2.6	4.5 3.4	0.5 0.5	5.0 3.7		1 3
C _{IN}	Input Capacitance	0			4				pF	
C _{PD}	Power Dissipation Capacitance ¹	3.3 5.0			6.3 9.5					2

Notes:

1. CPD is defined as the value of the internal equivalent capacitance which is derived from dynamic operating current consumption (ICCD) at no output loading and operating at 50% duty cycle (see Figure 2). CPD is related to ICCD dynamic operating current by the expression: ICCD = (CPD)(VCC)(fIN) + (ICC static).

AC Loading and Waveforms

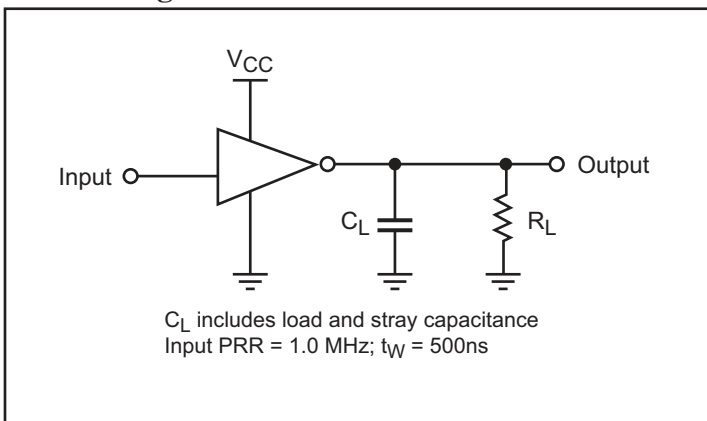

Figure 1. AC Loading and Waveforms

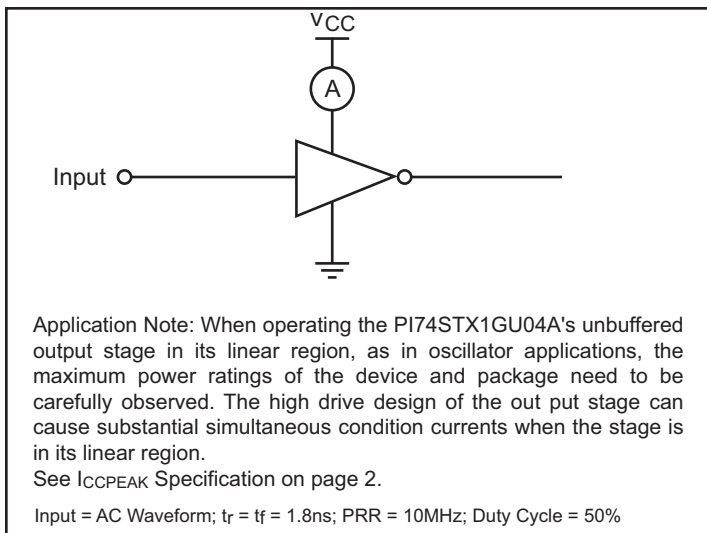

Figure 2. ICCD Test Circuit

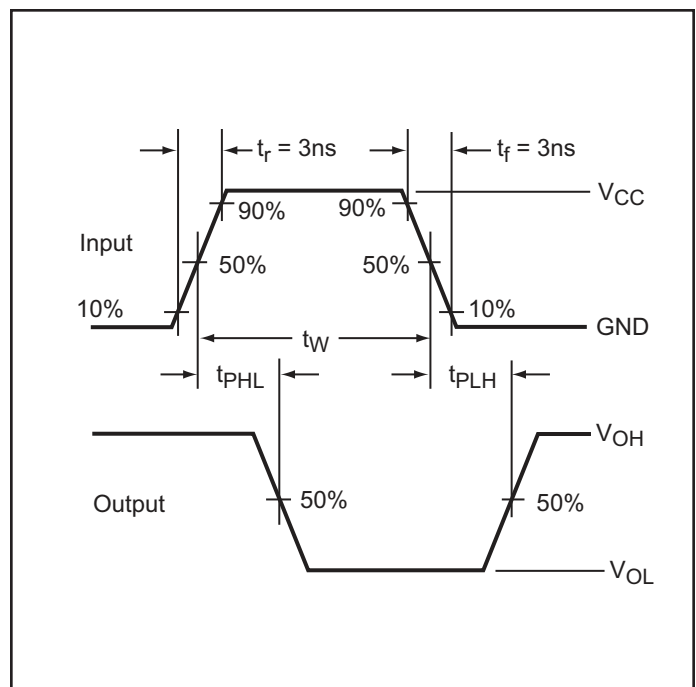
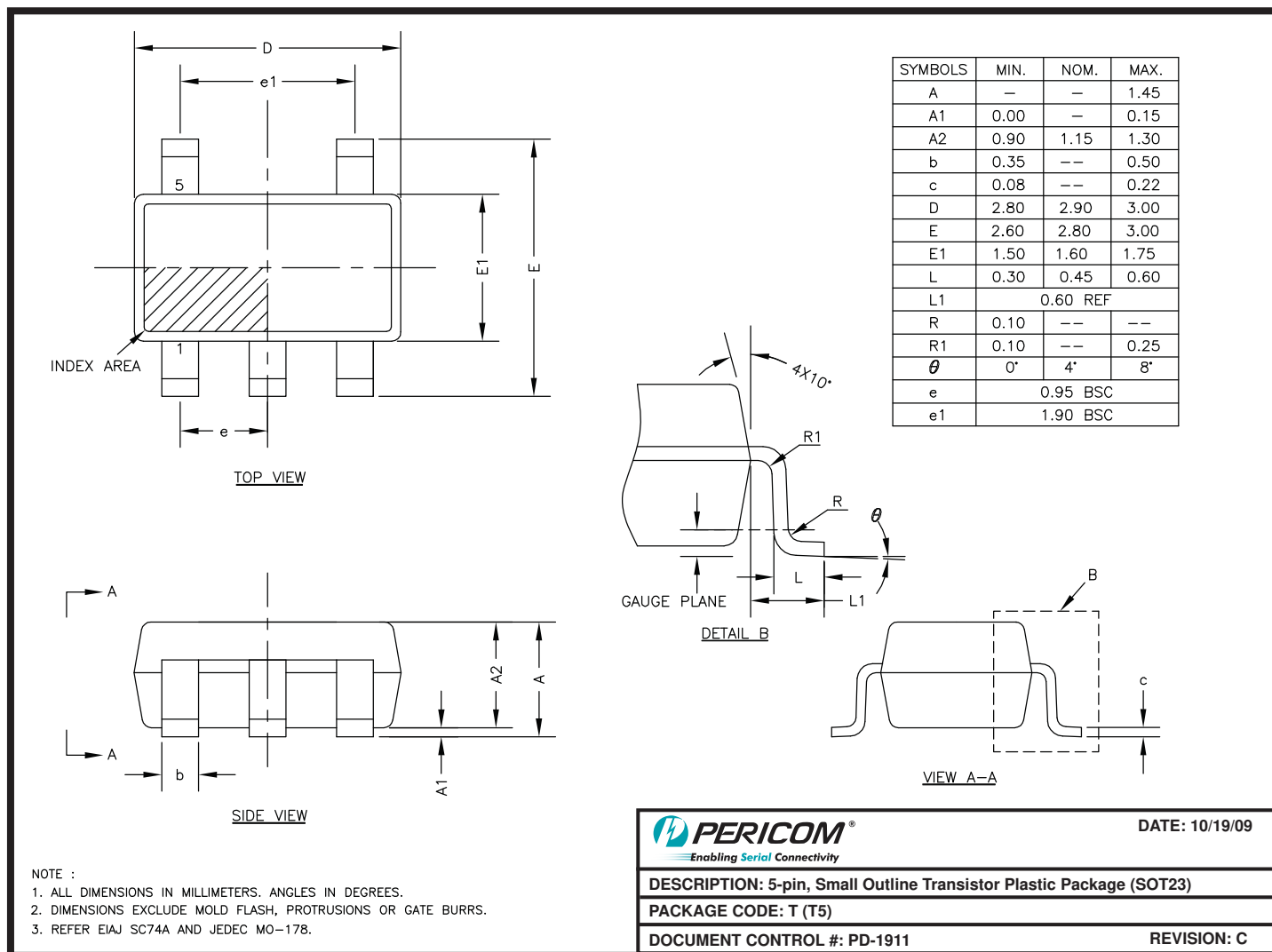

Figure 3. AC Waveform

Packaging Mechanical: 5-Pin SOT23 (T)



09-0130

DOCUMENT CONTROL NO.
 PD - 1901

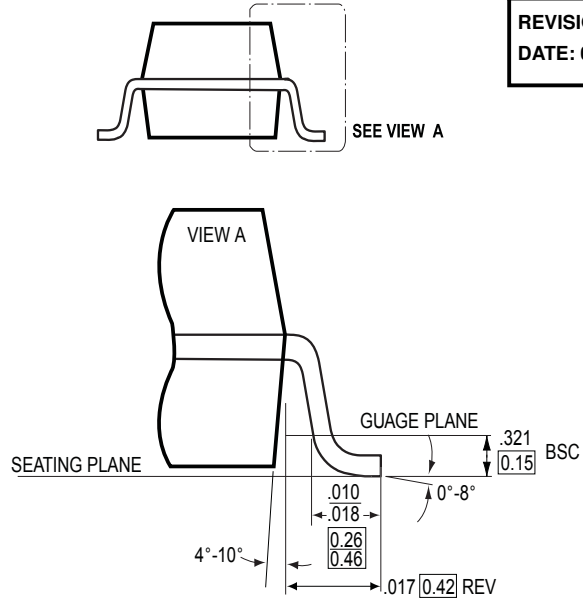
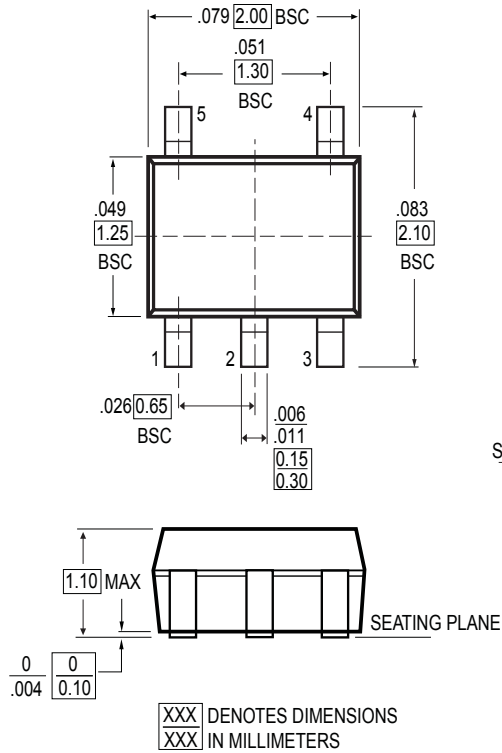
REVISION: D
DATE: 03/09/05

Notes:

1. Controlling dimensions in millimeters
2. Ref: JEDEC MO-203B/AA
3. Package Outline Exclusive of Mold Flash and Metal Burr

Pericom Semiconductor Corporation
 3545 N. 1st Street, San Jose, CA 95134
 1-800-435-2335 • www.pericom.com

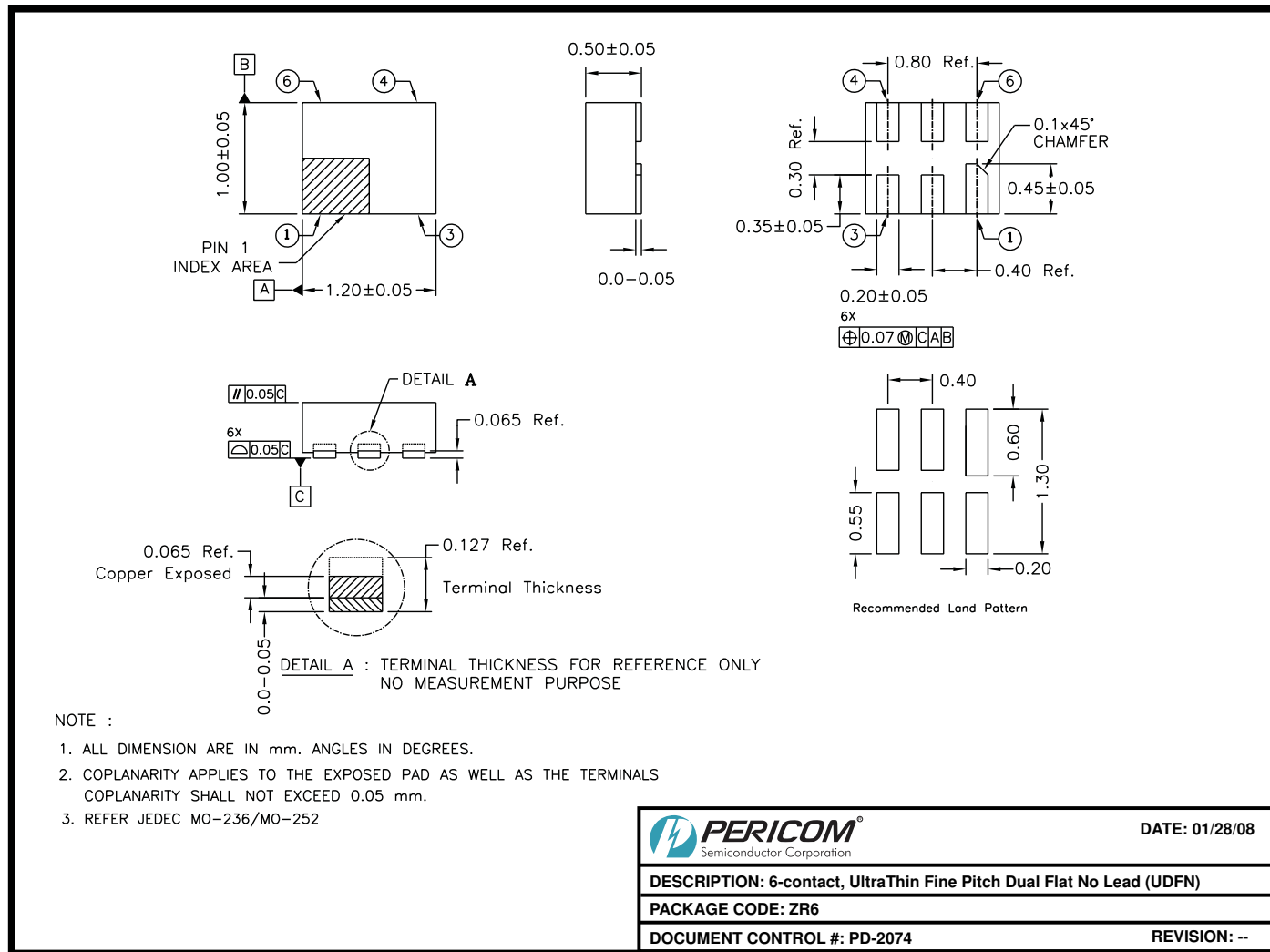
DESCRIPTION: 5-Pin, SC70
PACKAGE CODE: C



08-0035

Note:

- For latest package info, please check: <http://www.pericom.com/products/packaging/mechanicals.php>

Ordering Information⁽¹⁻³⁾

Ordering Code	Package Code	Package Description	Top Marking
PI74STX1GU04TEX	T	5-pin SOT23, Pb-free & Green	BH
PI74STX1GU04CEX	C	5-pin SC70, Pb-free & Green	BH
PI74STX1GU04ZREX	ZR	6-pin UDFN, Pb-Free and Green	BH

Notes:

1. Thermal characteristics can be found on the company web site at www.pericom.com/packaging/
2. E = Pb-free and Green
3. Adding an X suffix = Tape/Reel