

FEATURES

- Full-featured evaluation board for the AD7747
- PC evaluation software for control and measurement of the AD7747
- USB interface with cable

APPLICATIONS

- AD7747 performance evaluation
- Platform to integrate the AD7747 into system design

AD7747 PART DESCRIPTION

The AD7747 is a high-resolution Σ - Δ capacitance-to-digital converter (CDC). The capacitance to be measured is connected directly to the device inputs. The architecture features inherent high resolution (24-bit no missing codes, 18-bit effective resolution at a 16.6 Hz data rate), high linearity ($\pm 0.01\%$), and high accuracy (± 4 fF factory calibrated). The AD7747 capacitance input range is ± 8 pF (changing), while it can accept up to 17 pF absolute capacitance (not changing), which is compensated by an on-chip digital-to-capacitance converter (CAPDAC).

The AD7747 is designed for single-ended or differential capacitive sensors with one plate connected to ground. For floating capacitive sensors, the AD7745 or AD7746 is recommended.

The part has an on-chip temperature sensor with resolution of 0.1°C and accuracy of $\pm 2^\circ\text{C}$. The on-chip voltage reference and the on-chip clock generator eliminate the need for any external components in most capacitive sensor applications. The part has a standard voltage input that, together with the differential reference input, allows easy interface to an external temperature sensor, such as an RTD, thermistor, or diode.

The AD7747 has a 2-wire, I²C[®]-compatible serial interface. The part operates from a single 3 V or 5 V power supply. It is specified over the automotive temperature range of -40°C to $+125^\circ\text{C}$ and is housed in a 16-lead TSSOP package.

More information on the AD7747 can be found in the AD7747 data sheet that is available from Analog Devices, Inc., and should be consulted in conjunction with this document when using the evaluation board.

EVALUATION BOARD DESCRIPTION

The evaluation board interfaces to the USB port of a PC. Evaluation software is available with the evaluation board, which allows the user to easily communicate with the AD7747.

Note that the AD7747 evaluation board software must be installed before connecting the AD7747 evaluation board to the PC.

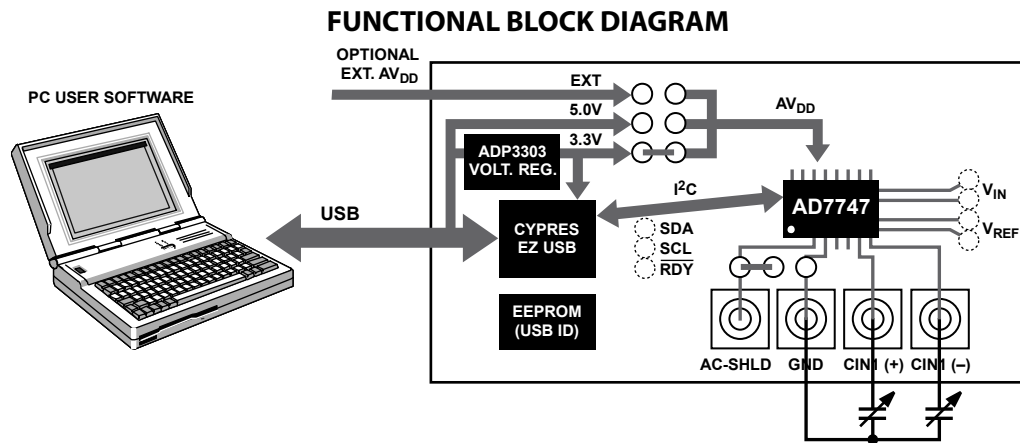

Figure 1.

Rev. 0

Evaluation boards are only intended for device evaluation and not for production purposes. Evaluation boards are supplied "as is" and without warranties of any kind, express, implied, or statutory including, but not limited to, any implied warranty of merchantability or fitness for a particular purpose. No license is granted by implication or otherwise under any patents or other intellectual property by application or use of evaluation boards. Information furnished by Analog Devices is believed to be accurate and reliable. However, no responsibility is assumed by Analog Devices for its use, nor for any infringements of patents or other rights of third parties that may result from its use. Analog Devices reserves the right to change devices or specifications at any time without notice. Trademarks and registered trademarks are the property of their respective owners. Evaluation boards are not authorized to be used in life support devices or systems.

TABLE OF CONTENTS

Features	1	Evaluation Board Interfacing.....	5
Applications.....	1	Configuring the AD7747 Evaluation Board.....	5
AD7747 Part Description	1	Evaluation Board Software.....	6
Evaluation Board Description.....	1	Performing a Noise Analysis.....	8
Functional Block Diagram	1	Saving User Configurations	8
Revision History	2	Evaluation Board Schematic	9
Evaluation Board Hardware.....	3	Evaluation Board Layout	10
Power Supplies	3	Ordering Information.....	11
I ² C Interface Configuration Options	3	Ordering Guide	11
Connectors	4	ESD Caution.....	11

REVISION HISTORY

12/08—Revision 0: Initial Version

EVALUATION BOARD HARDWARE

POWER SUPPLIES

The board is powered via the 5 V supply from the USB connector, J1. This 5 V supply can be used to power the AD7747 directly, or a 3.3 V regulated voltage from the on-board ADP3303 (high precision, low power, 3.3 V output voltage regulator) can also be used. Alternatively, the AD7747 can be powered using an external 3 V or 5 V power supply via J2 (see Table 2).

I²C INTERFACE CONFIGURATION OPTIONS

The AD7747 evaluation board allows different digital interface configurations by redirecting the I²C signals, SDA and SCL, on LK2.

Default

Links in the SDA and SCL positions of LK2 connect the USB microcontroller as the I²C bus master to the on-board AD7747, as shown in Figure 2. This allows easy use of the evaluation board with the PC software.

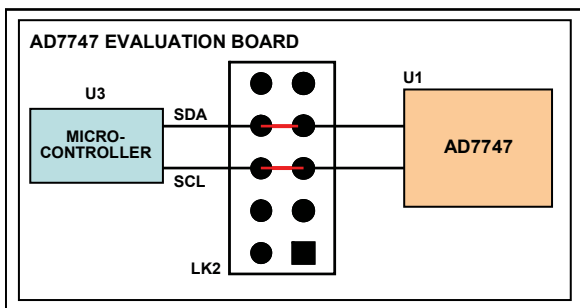

Figure 2. Evaluation Board in the Default Configuration

External Connection—USB

The AD7747 evaluation board allows customers to connect their own specific AD7747 application board to Pin 6 and Pin 8 of LK2. This enables customers, together with the PC evaluation software, to evaluate their application hardware using the AD7747 evaluation board only as a USB-to-I²C digital interface as shown in Figure 3.

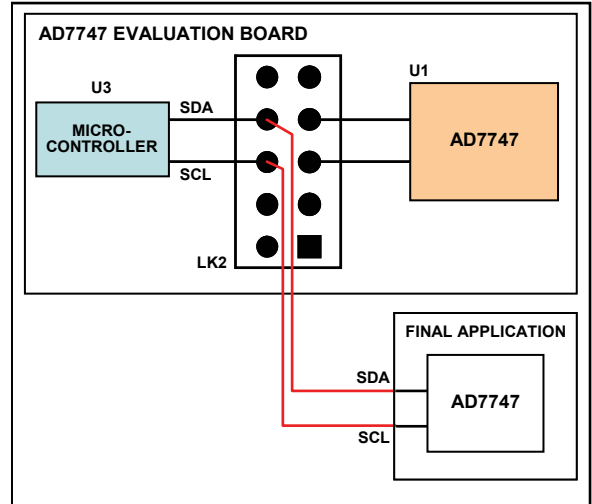

Figure 3. Evaluation Board as a USB-to-I²C Interface

External Connection—AD7747

The AD7747 evaluation board can be used for software development by connecting a customer-specific external microcontroller board to Pin 5 and Pin 7 of LK2, as shown in Figure 4, using the AD7747 CDC on the evaluation board as the sensing device.

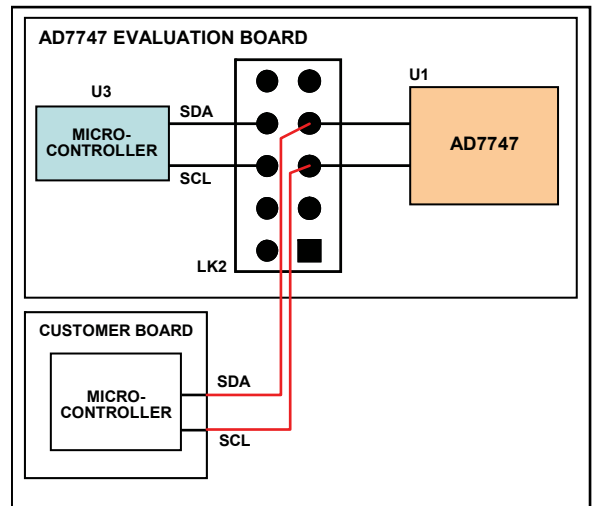

Figure 4. Evaluation Board Software Development Platform

EVAL-AD7747

CONNECTORS

There are four SMB connectors relevant to the operation of the AD7747 on this evaluation board. The functions of these connectors are outlined in Table 1

There are also headers marked LK1 to LK3 that allow flexibility in the use of the evaluation board, as described in Table 2.

Table 1. Connector Functions

Connector	Function
CIN1+	Subminiature BNC (SMB) connector. The capacitive input signal for the CIN1+ input of the AD7747 is applied to this connector.
CIN1-	Subminiature BNC (SMB) connector. The capacitive input signal for the CIN1- input of the AD7747 is applied to this connector.
GND	Subminiature BNC (SMB) connector. This socket is connected to the analog ground plane on the AD7747 evaluation board. The grounded terminal of the capacitive input signal should be applied to this connector.
AC-SHLD	Subminiature BNC (SMB) connector. This connector makes the AC-SHLD signal from the AD7747 available.

Table 2. Evaluation Board Link Settings

Link	Default	Description
LK1	3.3 V	LK1 is used to select the power source for the AD7747. LK1 in the 5.0 V position selects the 5 V supply from the USB connector, J1. LK1 in the 3.3 V position (default) selects the 3.3 V regulated output from the on-board ADP3303 voltage regulator. LK1 in the V_EXT position selects an external power supply, supplied via J2.
LK2	SDA, SCL, RDY linked	LK2 is a 10-pin (2 × 5) straight header. This link allows ease of access to the power supply lines ($\overline{AV_{DD}}$, AGND, DV_{DD} , and DGND) as well as the 2-wire serial interface signals, SDA and SCL, and the data ready signal, RDY. See the I ² C Interface Configuration Options section for details.
LK3	AC-SHLD	LK3 is a 3-pin single row header. It allows the CIN1+, CIN1-, and GND SMB connectors to be connected either to AC-SHLD or to analog ground.

EVALUATION BOARD INTERFACING

Interfacing to the evaluation board is via a standard USB connector, J1. J1 is used to connect the evaluation board to the USB port of a PC. A standard USB connector cable is included with the AD7747 evaluation board to allow the evaluation board to interface with the USB port of the PC. Because the board is powered via the USB connector, there is no need for an external power supply, although one can be connected if preferred via J2.

Communication between the AD7747 and the PC is over the USB interface. The on-board USB controller controls this communication.

Note that the AD7747 evaluation board software must be installed (using the supplied AD7747 evaluation kit CD) before connecting the evaluation board to the PC.

After the AD7747 evaluation board software has been installed, connect the board to the PC via J1 on the AD7747 evaluation board and the USB port on the PC using the supplied USB

connector cable. The green colored POWER LED should light up on the evaluation board. The PC automatically finds the new USB device and identifies it as **AD774x Evaluation Board**.

Click **Next** and follow the on-screen instructions that appear automatically. During the installation process, if the window shown in Figure 5 appears, click **Continue Anyway** to successfully complete the installation of the AD7747 evaluation board.

CONFIGURING THE AD7747 EVALUATION BOARD

The AD7747 evaluation board is configured to allow any capacitive input with one terminal connected to ground to be interfaced to CIN1 of the AD7747. To do this, connect one terminal of the capacitive input to the SMB connector labeled CIN1+ or CIN1-, and then connect the grounded terminal of the capacitive input to the SMB connector labeled GND.

The AD7747 operating mode can then be configured using the AD7747 evaluation software (see the Evaluation Board Software section).

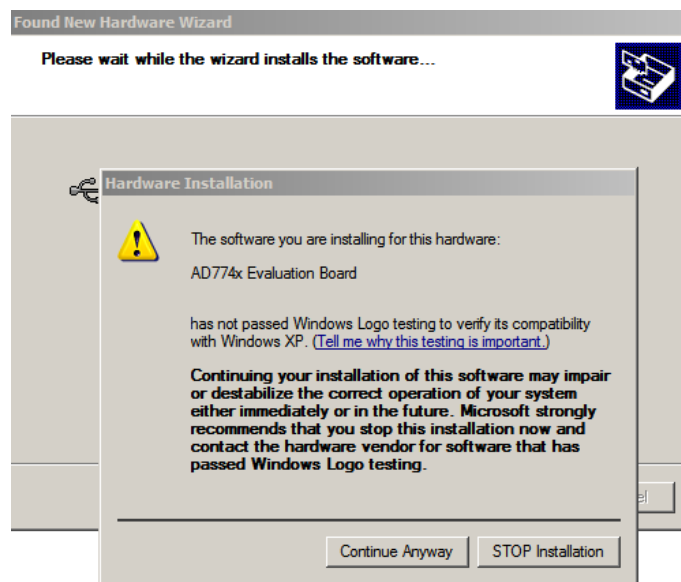

Figure 5. Windows XP Warning

EVAL-AD7747

EVALUATION BOARD SOFTWARE

Use the following steps to run the AD7747 evaluation board software:

1. Select **Start Menu > Program Files > Analog Devices\AD7747 Evaluation Software\AD7747**.
The application displays the **Real Time** tab by default (see Figure 6).
2. To get started, click the **Quick Setup** button.

This enables the capacitive input channel, sets the update rate, and places the part in continuous conversion so that the part can measure directly any capacitance placed across the CIN1+/CIN1– and GND SMB connectors.

3. For complete setup details, click the **Setup** button.
The tab shown in Figure 7 is displayed.

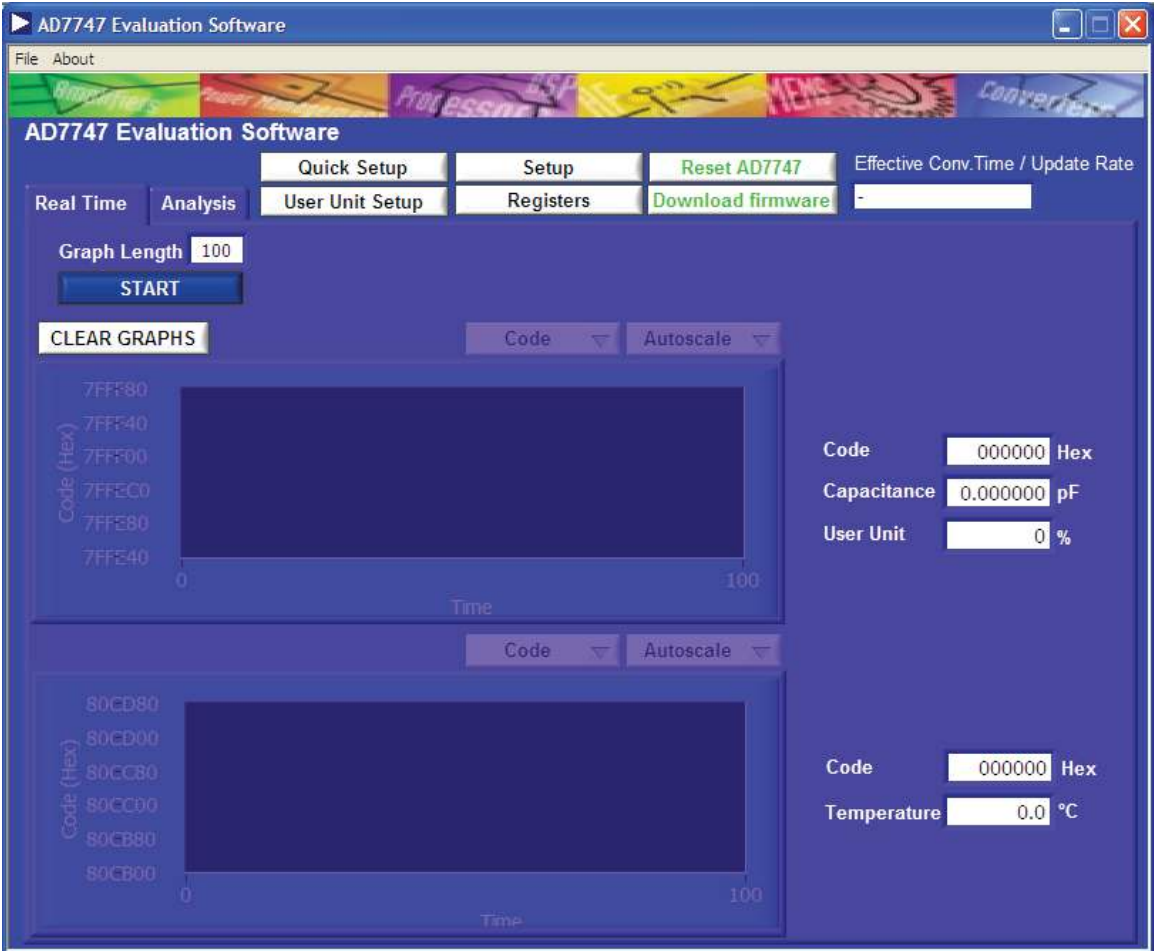

Figure 6. Evaluation Software Main Window

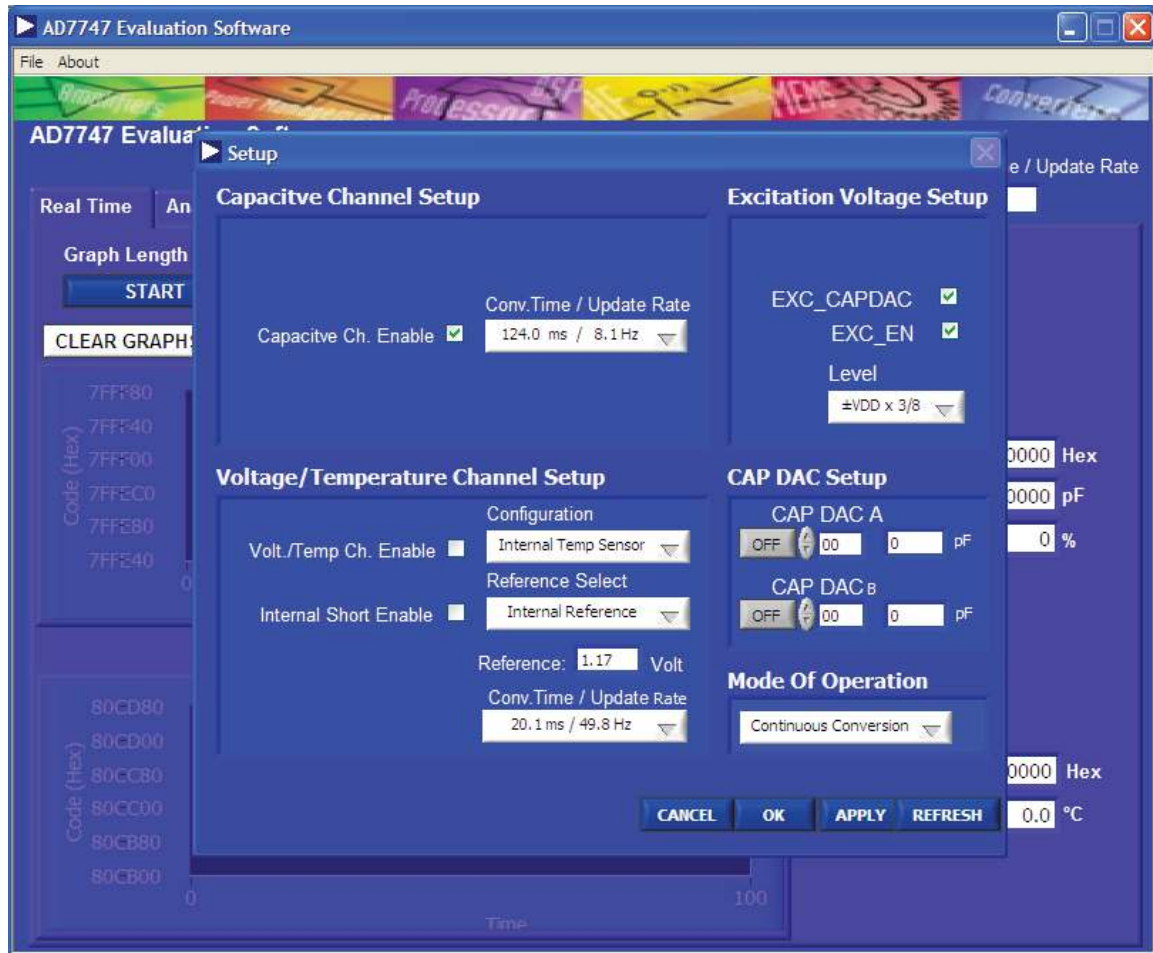

Figure 7. Setup Tab

4. Use the **Setup** tab to enable the capacitive channel and the voltage/temperature channel. Also, use this tab to configure the CAP DACs and the mode of operation for the AD7747. Alternatively, select the **Registers** button on the **Real Time** tab to display a detailed register map of all available registers and current user settings. You can use this tab if you require a more detailed configuration of the AD7747.
5. Click **OK** to return to the **Real Time** tab.
6. Without any capacitance connected to the AD7747 evaluation board, click **START**. The samples gathered are displayed graphically in real time. The samples are also displayed in hexadecimal and capacitance formats. The capacitance should read approximately 0 pF (with no capacitance connected). Note that the window is updated in real time.
7. Click **STOP** to stop displaying the data.

PERFORMING A NOISE ANALYSIS

1. With the quick setup for capacitive Channel 1 still in place, select the **Analysis** tab to display analysis options (shown in Figure 8).

2. Enter the required number of samples and click the **START** button.

Once the samples are gathered, you can display them as a waveform or as a histogram. The average, rms noise, peak-to-peak noise, rms resolution, and peak-to-peak resolution figures relating to the gathered set of samples are displayed on the right-hand side of the screen. These figures can be displayed in codes, capacitance, or a user-configured unit.

3. To save this set of gathered samples, select **File > Save Binary Data**.

A prompt is displayed.

4. Select the directory and file name to which the data is to be saved.

The default file name is **Binary Data.txt**.

SAVING USER CONFIGURATIONS

1. To save any configuration, select **File > Save Settings**. A prompt is displayed.

2. Select the directory and file name to which the current user configuration is to be saved.

The default file name is **Settings.txt**. The user unit, user offset, and user range are saved together with the complete register map, as it appears on the **Registers** tab.

3. To reload these settings at any time, select **File > Load Settings**.

A prompt is displayed that selects, by default, the user configuration previously saved in **Settings.txt**. Note that a configuration must be saved before it can be loaded.

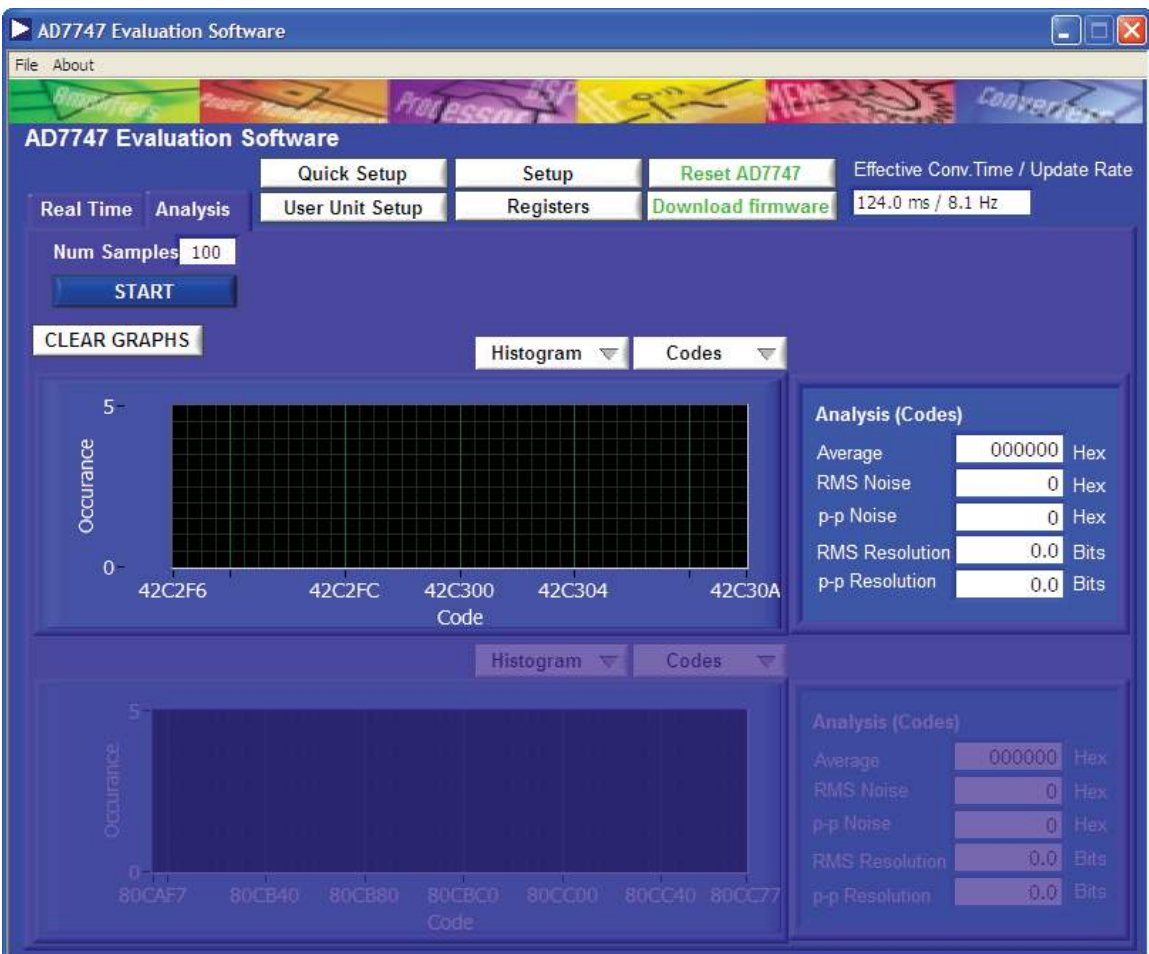

Figure 8. Analysis Tab

EVALUATION BOARD SCHEMATIC

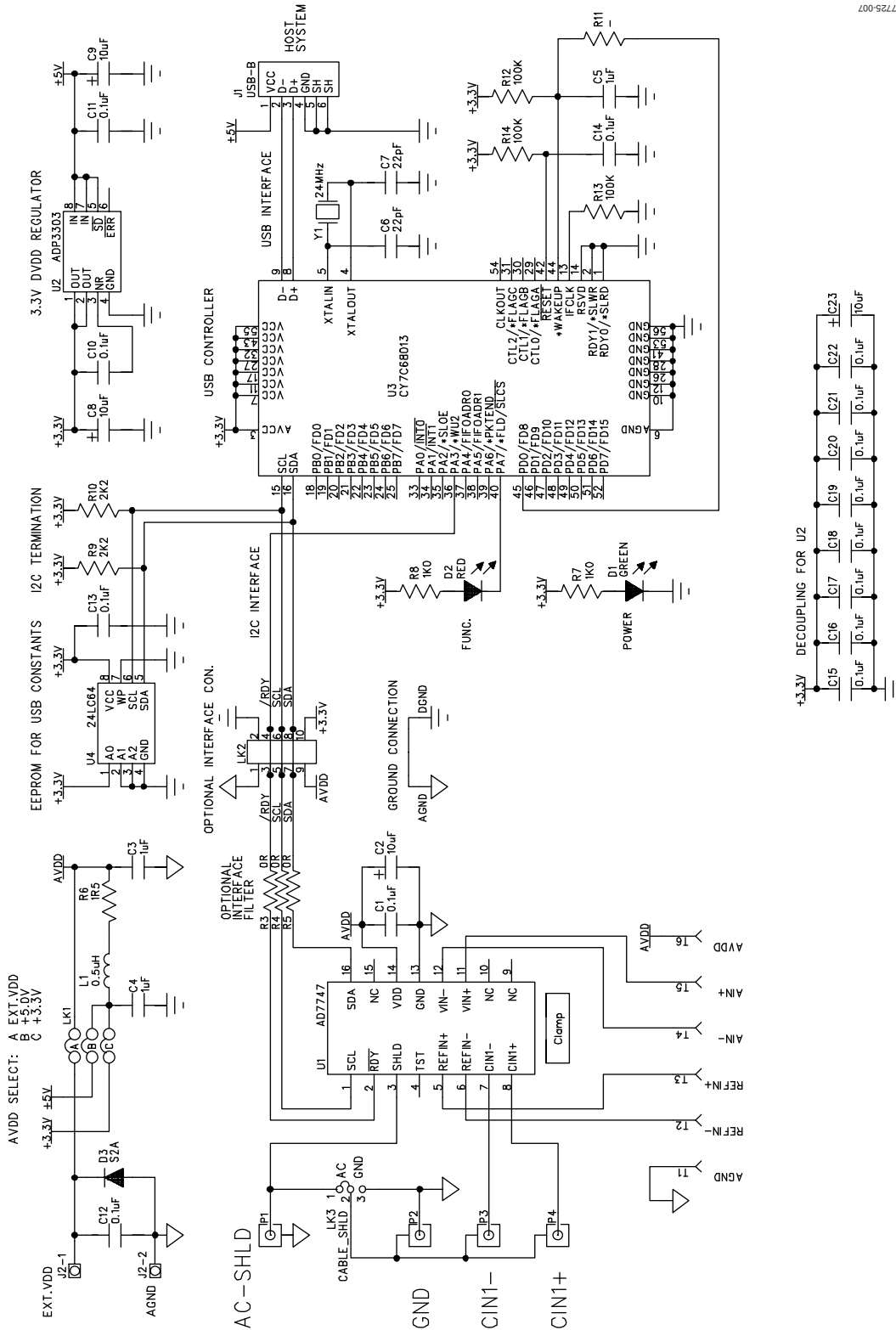
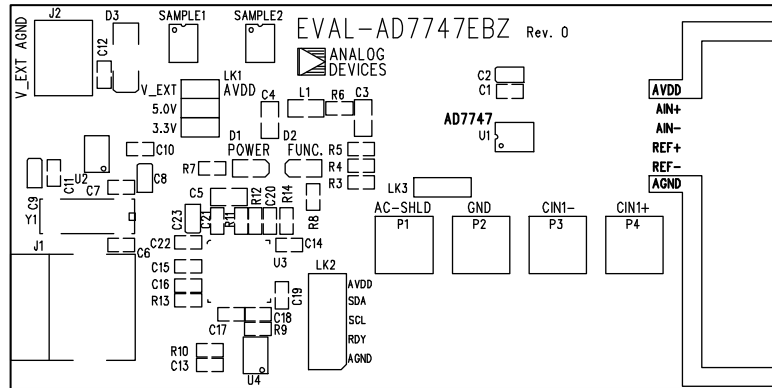

Figure 9. Evaluation Board Schematic

EVALUATION BOARD LAYOUT



Eval-AD7747EBZ Rev. 0 (Component Side View)

Figure 10. Component ID

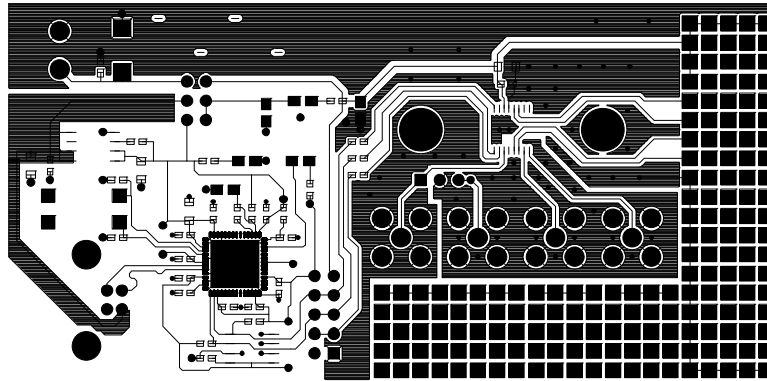

Eval-AD7747EBZ Rev. 0 (Component Side View) Component Side

Figure 11. Top Layer

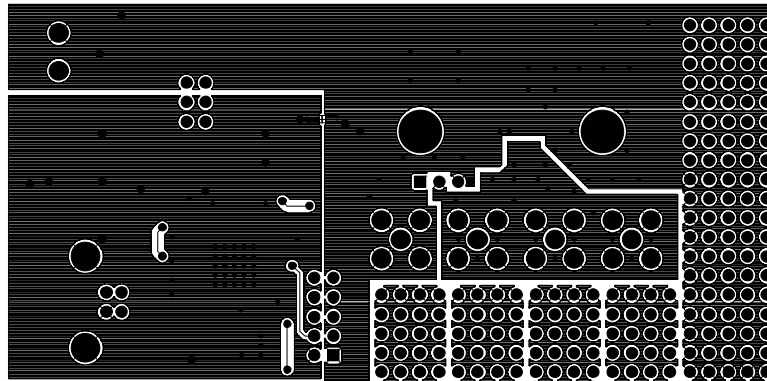

Eval-AD7747EBZ Rev. 0 (Component Side View)

Figure 12. Bottom Layer

ORDERING INFORMATION

ORDERING GUIDE

Model	Description
EVAL-AD7747EBZ ¹	Evaluation Board

¹ Z = RoHS Compliant Part.

ESD CAUTION



ESD (electrostatic discharge) sensitive device. Charged devices and circuit boards can discharge without detection. Although this product features patented or proprietary protection circuitry, damage may occur on devices subjected to high energy ESD. Therefore, proper ESD precautions should be taken to avoid performance degradation or loss of functionality.

EVAL-AD7747

NOTES