

# GN 425.3

Steel / Stainless Steel

# Cabinet "U" Handles

Round, with Alignment Holes, Weldable



**JW WINCO**  
A Ganter Company

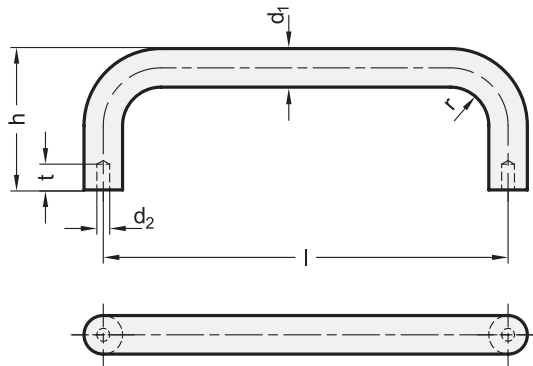

SS Stainless Steel

### Application and mounting example

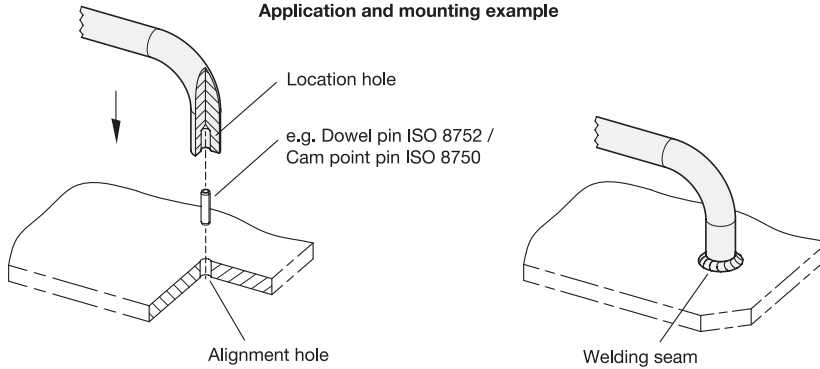

## Universal table

Dimensions in: millimeters - inches

d <sub>1</sub>	Length l ±0.5			d <sub>2</sub> H12	h	r	t
8 .31	64 2.52	88 3.46	100 3.94	3 .12	35 1.38	10 .39	5 .20
10 .39	100 3.94	125 4.92	160 6.30	3 .12	43 1.69	12 .47	5 .20
12 .47	125 4.92	160 6.30	200 7.87	4 .16	51 2.01	14 .55	6 .24
16 .63	125 4.92	160 6.30	200 7.87	4 .16	59 2.32	18 .71	6 .24
20 .79	200 7.87	250 9.84	-	5 .20	68 2.68	22 .87	8 .31

### Specification

- Steel, matte shot-blasted finish **ST**
- Stainless steel, matte shot-blasted finish **NI**  
European Standard No. 1.4301 (AISI 304)
- RoHS compliant

### Information

GN 425.3 cabinet "U" handles have no thread and are designed for applications that require the handle to be welded or for applications that require special threads, holes, etc. for mounting.

The holes d<sub>2</sub> serve, if necessary, for inserting dowel pins or guide pins that provide a simple method for positioning and mounting the cabinet "U" handle in place via the alignment holes in the counter part for the welding process.

The manufacturing process (bending) allows the production of special lengths in relatively small quantities.

#### see also...

- Tubular Cabinet "U" Handles GN 426.3 (Steel, Weldable)
- Cabinet "U" Handles GN 425 (Steel / Aluminum / Stainless Steel)
- Cabinet "U" Handles GN 426 (Aluminum)

### On request

- For certain minimum quantities, other lengths according to customer requirements

<b>How to order</b> <b>GN 425.3-12-160-NI</b>	1	Handle diameter d <sub>1</sub>
	2	Length l
	3	Material