

**REVISIONS**

LTR	DESCRIPTION	DATE (YR-MO-DA)	APPROVED
A	Change to military drawing format. Page 8, table I; change group A subgroup for +V <sub>R</sub> and -V <sub>R</sub> ; add end-point electrical limits for +V <sub>RINT</sub> and -V <sub>RINT</sub> . Page 10; change output offset adjust and temperature effect for device types 03 and 04 trim circuits.	86-12-31	W. Heckman
B	Add device types 05 and 06. Inactivate case outline X. Add case outlines C, Y, and 3. Add vendors CAGE 33256 and 34707. Change drawing CAGE to 67268. Editorial changes throughout.	89-08-01	W. Heckman
C	Changed to reflect MIL-H-38534 processing. Update document. Editorial changes throughout.	92-12-22	K. A. Cottongim
D	Changes in accordance with NOR 5962-R212-93.	93-08-17	K. A. Cottongim
E	Changes in accordance with NOR 5962-R045-93.	93-11-18	K. A. Cottongim
F	Changes to table I, note 1.	99-01-08	K. A. Cottongim

THE ORIGINAL FIRST PAGE OF THIS DRAWING HAS BEEN REPLACED.

**CURRENT CAGE CODE 67268**

REV																				
SHEET																				
REV	F	F																		
SHEET	15	16																		
REV STATUS OF SHEETS	REV		F	F	F	F	F	F	F	F	F	F	F	F	F	F	F	F	F	
	SHEET		1	2	3	4	5	6	7	8	9	10	11	12	13	14				

PMIC N/A	PREPARED BY Donald R. Osborne	<b>DEFENSE SUPPLY CENTER COLUMBUS</b> P. O. BOX 3990 COLUMBUS, OHIO 43216-5000			
<b>STANDARD MICROCIRCUIT DRAWING</b>  THIS DRAWING IS AVAILABLE FOR USE BY ALL DEPARTMENTS AND AGENCIES OF THE DEPARTMENT OF DEFENSE  AMSC N/A	CHECKED BY Ray Monnin				MICROCIRCUIT, HYBRID, LINEAR, PRECISION VOLTAGE REFERENCES, THIN FILM
	APPROVED BY William K. Heckman				
	DRAWING APPROVAL DATE 86-04-28				
	REVISION LEVEL  F	SIZE <b>A</b>	CAGE CODE <b>14933</b>	<b>85030</b>	
		SHEET	1	OF	16

1. SCOPE

1.1 Scope. This drawing documents one product assurance class, class H (high reliability) and a choice of case outlines and lead finishes are available and are reflected in the Part or Identifying Number (PIN).

1.2 PIN. The PIN shall be as shown in the following example:



1.2.1 Device type(s). The device type(s) shall identify the circuit function as follows:

<u>Device type</u>	<u>Generic number</u>	<u>Circuit function</u>
01, 02	2700	Precision +10.000-volt reference
03, 04	2702	Precision ±10.000-volt reference
05, 06	2701	Precision -10.000-volt reference

1.2.2 Case outline(s). The case outline(s) shall be as designated in MIL-STD-1835 and as follows:

<u>Outline letter</u>	<u>Descriptive designator</u>	<u>Terminals</u>	<u>Package style</u>
C	GDIP1-T14 or CDIP1-T14	14	Dual-in-line
X	See figure 1	14	Dual-in-line
Y	See figure 1	14	Dual-in-line
3	CQCC1-N28	28	Square leadless chip-carrier

1.2.3 Lead finish. The lead finish shall be as specified in MIL-PRF-38534.

1.3 Absolute maximum ratings. 1/

Supply voltage ( $V_S$ ):	
$V_{CC}$ (device types 01, 02, 03, 04) .....	+20 V dc
$V_{EE}$ (device types 03, 04, 05, 06) .....	-20 V dc
Power dissipation ( $P_D$ ), $T_A = +25^\circ\text{C}$ :	
Device types 01, 02, 05, 06 .....	300 mW
Device types 03, 04 .....	450 mW
Storage temperature range .....	-65° C to +150° C
Lead temperature (soldering, 10 seconds) .....	+300° C
Short circuit protection (to GND) .....	Continuous
Thermal resistance:	
Junction-to-case ( $\theta_{JC}$ ):	
Case outlines C and 3 .....	See MIL-STD-1835
Case outline X .....	7° C/W
Case outline Y .....	8° C/W
Junction-to-ambient ( $\theta_{JA}$ ):	
Case outline X .....	30° C/W
Case outline Y .....	25° C/W

1/ Stresses above the absolute maximum rating may cause permanent damage to the device. Extended operation at the maximum levels may degrade performance and affect reliability.

<b>STANDARD MICROCIRCUIT DRAWING DEFENSE SUPPLY CENTER COLUMBUS COLUMBUS, OHIO 43216-5000</b>	<b>SIZE A</b>		<b>85030</b>
		<b>REVISION LEVEL F</b>	<b>SHEET 2</b>

1.4 Recommended operating conditions.

Supply voltage range (V <sub>CC</sub> ) .....	+13.5 V dc to +16.5 V dc
Supply voltage range (V <sub>EE</sub> ) .....	-13.5 V dc to -16.5 V dc
Output current .....	5 mA <sup>1/</sup>
Ambient operating temperature range (T <sub>A</sub> ) .....	-55° C to +125° C

2. APPLICABLE DOCUMENTS

2.1 Government specification, standards, and handbook. The following specification, standards, and handbook form a part of this drawing to the extent specified herein. Unless otherwise specified, the issues of these documents are those listed in the issue of the Department of Defense Index of Specifications and Standards (DoDISS) and supplement thereto, cited in the solicitation.

SPECIFICATION

DEPARTMENT OF DEFENSE

MIL-PRF-38534 - Hybrid Microcircuits, General Specification for.

STANDARDS

DEPARTMENT OF DEFENSE

- MIL-STD-883 - Test Methods and Procedures for Microelectronics.
- MIL-STD-973 - Configuration Management.
- MIL-STD-1835 - Microcircuit Case Outlines.

HANDBOOK

DEPARTMENT OF DEFENSE

MIL-HDBK-780 - Standard Microcircuit Drawings.

(Unless otherwise indicated, copies of the specification, standards, and handbook are available from the Standardization Document Order Desk, 700 Robbins Avenue, Building 4D, Philadelphia, PA 19111-5094.)

2.2 Order of precedence. In the event of a conflict between the text of this drawing and the references cited herein, the text of this drawing takes precedence. Nothing in this document, however, supersedes applicable laws and regulations unless a specific exemption has been obtained.

3. REQUIREMENTS

3.1 Item requirements. The individual item performance requirements for device class H shall be in accordance with MIL-PRF-38534. Compliance with MIL-PRF-38534 may include the performance of all tests herein or as designated in the device manufacturer's Quality Management (QM) plan or as designated for applicable device class. Therefore, the tests and inspections herein may not be performed for applicable device class (see MIL-PRF-38534). Furthermore, the manufacturers may take exceptions or use alternate methods to the tests and inspections herein and not perform them. However, the performance requirements as defined in MIL-PRF-38534 shall be met for the applicable device class. The modification in the QM plan shall not affect the form, fit, or function as described herein.

3.2 Design, construction, and physical dimensions. The design, construction, and physical dimensions shall be as specified in MIL-PRF-38534 and herein.

<sup>1/</sup> With resistive load to pin 7 (common).

<b>STANDARD MICROCIRCUIT DRAWING DEFENSE SUPPLY CENTER COLUMBUS COLUMBUS, OHIO 43216-5000</b>	<b>SIZE A</b>		<b>85030</b>
		<b>REVISION LEVEL F</b>	<b>SHEET 3</b>

3.2.1 Case outline(s). The case outline(s) shall be in accordance with 1.2.2 herein and figure 1.

3.2.2 Terminal connections. The terminal connections shall be as specified on figure 2.

3.2.3 Trim circuits. The trim circuits shall be as specified on figure 3.

3.3 Electrical performance characteristics. Unless otherwise specified herein, the electrical performance characteristics are as specified in table I and shall apply over the full specified operating temperature range.

3.4 Electrical test requirements. The electrical test requirements shall be the subgroups specified in table II. The electrical tests for each subgroup are defined in table I.

3.5 Marking of device(s). Marking of device(s) shall be in accordance with MIL-PRF-38534. The device shall be marked with the PIN listed in 1.2 herein. In addition, the manufacturer's vendor similar PIN may also be marked as listed in QML-38534.

3.6 Data. In addition to the general performance requirements of MIL-PRF-38534, the manufacturer of the device described herein shall maintain the electrical test data (variables format) from the initial quality conformance inspection group A lot sample, for each device type listed herein. Also, the data should include a summary of all parameters manually tested, and for those which, if any, are guaranteed. This data shall be maintained under document revision level control by the manufacturer and be made available to the preparing activity (DSCC-VA) upon request.

3.7 Certificate of compliance. A certificate of compliance shall be required from a manufacturer in order to supply to this drawing. The certificate of compliance (original copy) submitted to DSCC-VA shall affirm that the manufacturer's product meets the performance requirements of MIL-PRF-38534 and herein.

3.8 Certificate of conformance. A certificate of conformance as required in MIL-PRF-38534 shall be provided with each lot of microcircuits delivered to this drawing.

#### 4. QUALITY ASSURANCE PROVISIONS

4.1 Sampling and inspection. Sampling and inspection procedures shall be in accordance with MIL-PRF-38534 or as modified in the device manufacturer's Quality Management (QM) plan. The modification in the QM plan shall not affect the form, fit, or function as described herein.

4.2 Screening. Screening shall be in accordance with MIL-PRF-38534. The following additional criteria shall apply:

a. Burn-in test, method 1015 of MIL-STD-883.

(1) Test condition A, B, C, or D. The test circuit shall be maintained by the manufacturer under document revision level control and shall be made available to either DSCC-VA or the acquiring activity upon request. Also, the test circuit shall specify the inputs, outputs, biases, and power dissipation, as applicable, in accordance with the intent specified in test method 1015 of MIL-STD-883.

(2)  $T_A$  as specified in accordance with table I of method 1015 of MIL-STD-883.

b. Interim and final electrical test parameters shall be as specified in table II herein, except interim electrical parameter tests prior to burn-in are optional at the discretion of the manufacturer.

STANDARD MICROCIRCUIT DRAWING DEFENSE SUPPLY CENTER COLUMBUS COLUMBUS, OHIO 43216-5000	SIZE <b>A</b>		<b>85030</b>
		REVISION LEVEL <b>F</b>	SHEET <b>4</b>

TABLE I. Electrical performance characteristics.

Test	Symbol	Conditions <sup>1/</sup> -55° C ≤ T <sub>A</sub> ≤ +125° C unless otherwise specified		Group A subgroups	Device type	Limits		Unit
						Min	Max	
Selection output error <sup>2/</sup>	+V <sub>R</sub>	+10.000 V output		4	01	-5.0	+5.0	mV
				5, 6		-8.0	+8.0	
		+10.000 V output		4	02, 04	-2.5	+2.5	
				5, 6		-5.5	+5.5	
		+10.000 V output		4	03	-5.0	+5.0	
				5, 6		-10	+10	
	-V <sub>R</sub>	-10.000 V output		4	03, 05	+5.0	-5.0	
				5, 6		+10	-10	
		-10.000 V output		4	04, 06	+2.5	-2.5	
				5, 6		+5.5	-5.5	
Interim output error	+V <sub>RINT</sub>	+10.000 V output T <sub>A</sub> = +25° C		1	01, 02, 03, 04	Initial	+5	
						End-point	-10	+10
	-V <sub>RINT</sub>	-10.000 V output T <sub>A</sub> = +25° C		1	03, 04, 05, 06	Initial	-5	
						End-point	+10	-10
Output adjust range for trim circuits (see figure 3)	+V <sub>RADJ</sub>	+10.000 V output, T <sub>A</sub> = +25° C		1	01, 02, 03, 04	-20	+20	
	-V <sub>RADJ</sub>	-10.000 V output, T <sub>A</sub> = +25° C		1	03, 04, 05, 06	+20	-20	
Quiescent current	I <sub>CC</sub>	V <sub>CC</sub> = +15 V, no load, T <sub>A</sub> = +25° C		1	01, 02		+14	mA
		V <sub>CC</sub> = +15 V V <sub>EE</sub> = -15 V, no load T <sub>A</sub> = +25° C		1	03, 04		+17	
	I <sub>EE</sub>	V <sub>CC</sub> = +15 V, no load V <sub>EE</sub> = -15 V T <sub>A</sub> = +25° C		1	03, 04		-4	
		V <sub>EE</sub> = -15 V, no load T <sub>A</sub> = +25° C		1	05, 06		-14	

See footnotes at end of table.

<b>STANDARD MICROCIRCUIT DRAWING DEFENSE SUPPLY CENTER COLUMBUS COLUMBUS, OHIO 43216-5000</b>	<b>SIZE A</b>		<b>85030</b>
		<b>REVISION LEVEL F</b>	<b>SHEET 5</b>

TABLE I. Electrical performance characteristics - Continued.

Test	Symbol	Conditions <sup>1/</sup> -55°C ≤ T <sub>A</sub> ≤ +125°C unless otherwise specified	Group A subgroups	Device type	Limits		Unit
					Min	Max	
Line regulation	+V <sub>RL</sub>	+10 V output, T <sub>A</sub> = +25°C, +13.5 V ≤ V <sub>CC</sub> ≤ +16.5 V	1	01, 02, 03, 04	-900	+900	μV
	-V <sub>RL</sub>	-10.000 V output, T <sub>A</sub> = +25°C, -13.5 V ≤ V <sub>EE</sub> ≤ -16.5 V	1	03, 04, 05, 06	+900	-900	
Load regulation	+V <sub>RLOAD</sub>	+10.000 V output, T <sub>A</sub> = +25°C, 0 ≤ I <sub>L</sub> ≤ 10 mA	1	01, 02, 03, 04	-500	+500	μV
	-V <sub>RLOAD</sub>	-10.000 V output, T <sub>A</sub> = +25°C, 0 ≤ I <sub>L</sub> ≤ 10 mA	1	03, 04, 05, 06	+500	-500	
Output current	+I <sub>L</sub>		1	01, 02, 03, 04	10		mA
			2, 3		5		
	-I <sub>L</sub>		1	03, 04, 05, 06	10		
			2, 3		5		
Output noise <sup>3/</sup>		V <sub>OUT</sub> = 10 V, no load, 0.1 Hz ≤ BW ≤ 10 Hz, T <sub>A</sub> = +25°C	4	01, 02, 03, 04, 05, 06		150	μV/ p-p

<sup>1/</sup> Unless otherwise specified, V<sub>IN</sub> = +15 V, R<sub>L</sub> = 2 kΩ to pin 7 (common).

<sup>2/</sup> Output voltage change as a function of temperature is determined using the box method. Each device is tested at -55°C, +25°C, and +125°C. At each temperature the output voltage (V<sub>OUT</sub>) must fall within the rectangular area bounded by the minimum and maximum temperatures. This method gives a maximum temperature coefficient of 9 ppm/°C and a typical value of 3 ppm/°C.

<sup>3/</sup> Parameter shall be tested as part of device initial characterization and after design and process changes. Parameter shall be guaranteed to limits specified in table I for all lots not specifically tested.

<b>STANDARD MICROCIRCUIT DRAWING DEFENSE SUPPLY CENTER COLUMBUS COLUMBUS, OHIO 43216-5000</b>	<b>SIZE A</b>		<b>85030</b>
		<b>REVISION LEVEL F</b>	<b>SHEET 6</b>

Case outline X.

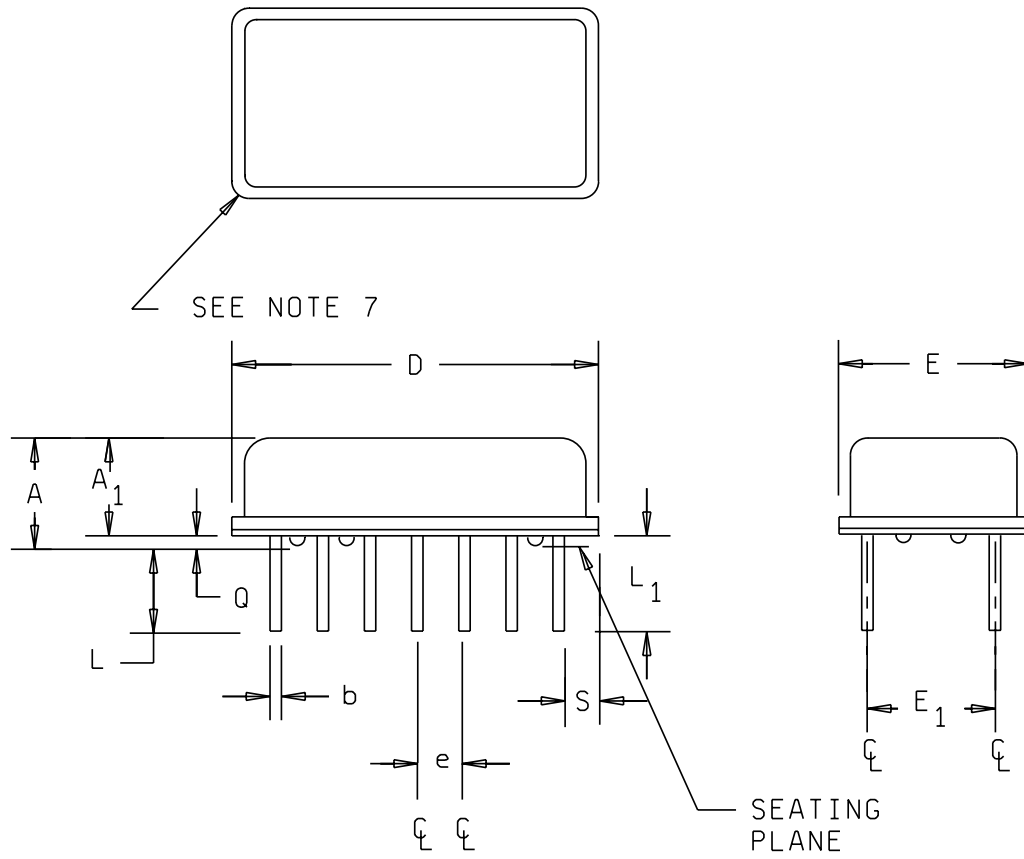

FIGURE 1. Case outline(s).

<b>STANDARD MICROCIRCUIT DRAWING DEFENSE SUPPLY CENTER COLUMBUS COLUMBUS, OHIO 43216-5000</b>	SIZE <b>A</b>		<b>85030</b>
		REVISION LEVEL <b>F</b>	SHEET <b>7</b>

Case outline X - Continued.

Dimensions					
Symbol	Inches		Millimeters		Notes
	Min	Max	Min	Max	
A	.215	.250	5.46	6.35	
A <sub>1</sub>	.175	.215	4.44	5.46	
b	.016	.020	0.41	0.51	8
φ <sub>b</sub>	.016	.020	0.41	0.51	4
D	.860	.885	21.84	22.48	4
E	.490	.520	12.45	13.21	7
E <sub>1</sub>	.295	.305	7.49	7.75	
e	.100 BSC		2.54 BSC		5, 8
L	.130	.255	3.30	6.48	
L <sub>1</sub>	.150	.290	3.81	7.37	
Q	.020	.035	0.51	0.89	3
S	.100	.160	2.54	4.07	
S <sub>1</sub>	.080	.180	2.03	4.57	
α	0°	15°	0°	15°	

NOTES:

1. Index area: A notch, square-package corner, or a pin one index point shall be located adjacent to pin one and within the shaded area shown. The manufacturer's identification shall not be used as a pin one identification mark.
2. Dimension Q shall be measured from the seating plane to the base plane.
3. This dimension allows for off-center lid, meniscus, and weld squash.
4. The basic pin spacing is .100 inch (2.54 mm) between centerlines. Each pin centerline shall be located within ±0.10 inch (0.25 mm) of its exact longitudinal position relative to pins 1 and 14.
5. Dimension S<sub>1</sub> is not used.
6. Lead center when a = 0°. E<sub>1</sub> shall be measured at the centerline of the leads (see MIL-STD-1835).
7. All leads: Increase maximum limit by .003 inch (0.08 mm) measured at the widest diameter when lead finish A or B is applied.
8. If this configuration is used, no polymer or organic materials shall be applied or molded to the bottom of the package or cover the leads.

FIGURE 1. Case outline(s) - Continued.

<b>STANDARD MICROCIRCUIT DRAWING DEFENSE SUPPLY CENTER COLUMBUS COLUMBUS, OHIO 43216-5000</b>	<b>SIZE A</b>		<b>85030</b>
		REVISION LEVEL <b>F</b>	SHEET <b>8</b>



Case outline Y.

14	8
1	7

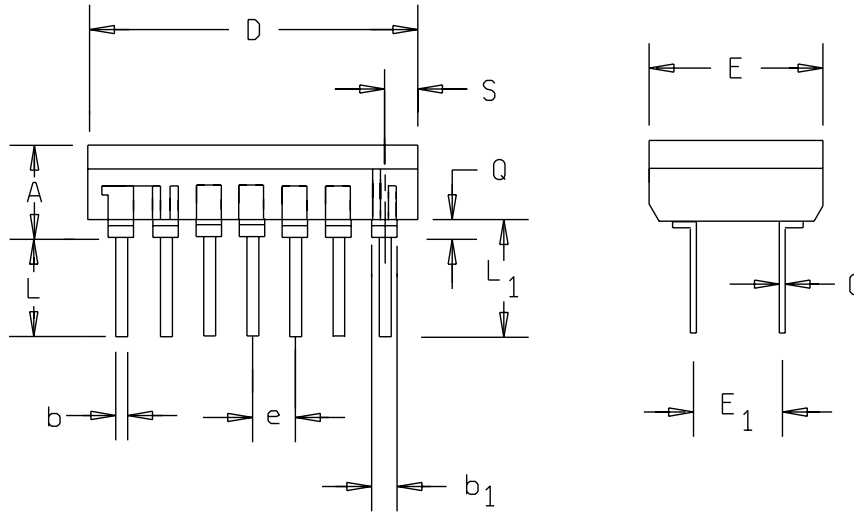

FIGURE 1. Case outline(s) - Continued.

<b>STANDARD MICROCIRCUIT DRAWING DEFENSE SUPPLY CENTER COLUMBUS COLUMBUS, OHIO 43216-5000</b>	<b>SIZE A</b>		<b>85030</b>
		<b>REVISION LEVEL F</b>	<b>SHEET 9</b>

Case outline Y - Continued.

Dimensions					
Symbol	Inches		Millimeters		Notes
	Min	Max	Min	Max	
A	.140	.200	3.56	5.08	
b	.014	.023	0.36	0.58	
b <sub>1</sub>	.030	.070	0.76	1.78	2
c	.008	.015	0.20	0.38	
D	.770	.810	19.56	20.57	
E	.480	.510	12.19	12.95	
E <sub>1</sub>	.295	.305	7.49	7.75	6
e	0.100 BSC		2.54 BSC		4, 7
L	.150	.200	3.81	5.08	
L <sub>1</sub>	.180	---	4.57	---	
Q	.015	.035	0.38	0.89	3
S	---	.137	---	3.48	5
S <sub>1</sub>	.060	---	1.52	---	5

NOTES:

1. Index area: A notch or a lead one identification mark is located adjacent to lead one.
2. The minimum limit for dimension b<sub>1</sub> may be .023 inch (0.58 mm) for all four corner leads only.
3. Dimension Q shall be measured from the seating plane to the base plane.
4. The basic pin spacing is .100 inch (2.54 mm) between centerlines.
5. Applies to all four corners.
6. E<sub>1</sub> shall be measured at the centerline of all the leads.

FIGURE 1. Case outline(s) - Continued.

<b>STANDARD MICROCIRCUIT DRAWING DEFENSE SUPPLY CENTER COLUMBUS COLUMBUS, OHIO 43216-5000</b>	SIZE <b>A</b>		<b>85030</b>
		REVISION LEVEL <b>F</b>	SHEET <b>10</b>

Device types 01 and 02.

2700		
Terminal number	Terminal symbol	
Case outlines	C, X, Y	Z
1	NC	V <sub>O</sub> SEN
2	NC	-IN
3	NC	REF GND
4	NC	GND SEN
5	NC	NC
6	NC	NC
7	GND	NC
8	NC	NC
9	NC	NC
10	TEST POINT	NC
11	V <sub>CC</sub>	NC
12	+10 V ADJ	NC
13	+10 V OUT	NC
14	+10 V ADJ	NC
15		NC
16		NC
17		NC
18		V <sub>Z</sub>
19		ZENER GND
20		NC
21		NC
22		V <sub>OS</sub>
23		V <sub>OS</sub>
24		POWER GND
25		V <sub>CC</sub>
26		+IN
27		V <sub>O</sub> FORCE
28		+10 V REF OUT

Device types 03 and 04.

2702		
Terminal number	Terminal symbol	
Case outlines	C, X, Y	Z
1	-10 V ADJ	V <sub>O</sub> SEN
2	-10 V OUT	-IN
3	-10 V ADJ	REF GND
4	V <sub>EE</sub>	GND SEN
5	NC	NC
6	NC	NC
7	GND	-V <sub>OS</sub>
8	NC	-V <sub>OS</sub>
9	NC	V <sub>EE</sub>
10	TEST POINT	+IN
11	V <sub>CC</sub>	V <sub>CC</sub>
12	+10 V ADJ	NC
13	+10 V OUT	-IN
14	+10 V ADJ	V <sub>O</sub> FORCE
15		-10 V REF OUT
16		V <sub>O</sub> SENSE
17		+10 V IN
18		V <sub>Z</sub>
19		ZENER GND
20		NC
21		NC
22		V <sub>OS</sub>
23		V <sub>OS</sub>
24		POWER GND
25		V <sub>CC</sub>
26		+IN
27		V <sub>O</sub> FORCE
28		+10 V REF OUT

FIGURE 2. Terminal connections.

<b>STANDARD MICROCIRCUIT DRAWING DEFENSE SUPPLY CENTER COLUMBUS COLUMBUS, OHIO 43216-5000</b>	SIZE <b>A</b>		<b>85030</b>
		REVISION LEVEL <b>F</b>	SHEET <b>11</b>

Device types 05 and 06.

2701		
Terminal number	Terminal symbol	
Case outlines	C, X, Y	Z
1	NC	NC
2	NC	NC
3	NC	REF GND
4	NC	GND SENSE
5	NC	NC
6	NC	NC
7	GND	-VOS
8	NC	-VOS
9	NC	VEE
10	TEST POINT	+IN
11	VEE	NC
12	-10 V ADJ	PWR GND
13	-10 V OUT	-IN
14	-10 V ADJ	VO FORCE
15		VO SENSE
16		VO SENSE
17		NC
18		VZ
19		ZENER GND
20		NC
21		NC
22		NC
23		NC
24		NC
25		NC
26		NC
27		NC
28		NC

FIGURE 2. Terminal connections - Continued.

<b>STANDARD MICROCIRCUIT DRAWING DEFENSE SUPPLY CENTER COLUMBUS COLUMBUS, OHIO 43216-5000</b>	<b>SIZE A</b>		<b>85030</b>
		<b>REVISION LEVEL F</b>	<b>SHEET 12</b>

Device types 01 and 02.

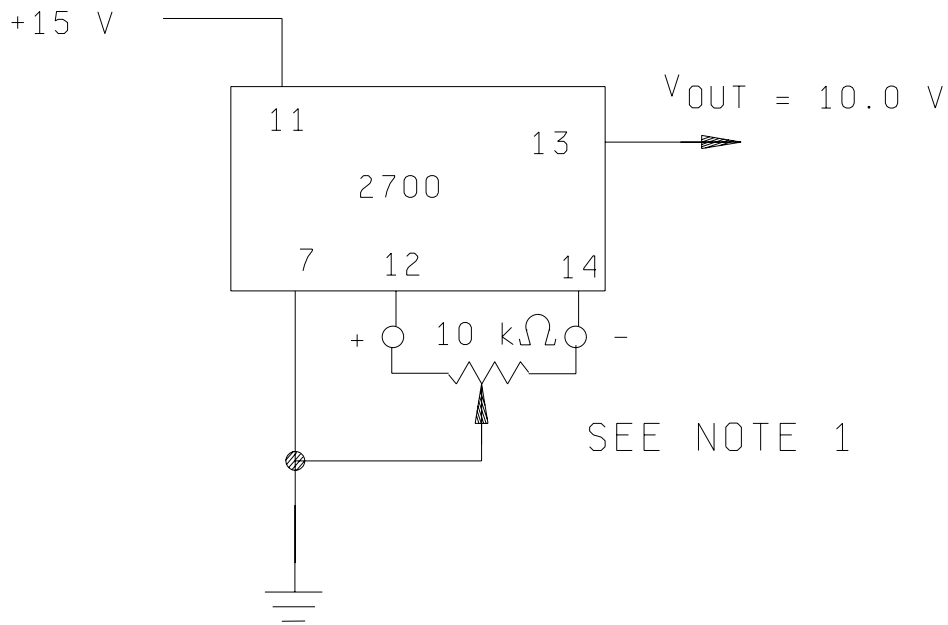

Device types 03 and 04.

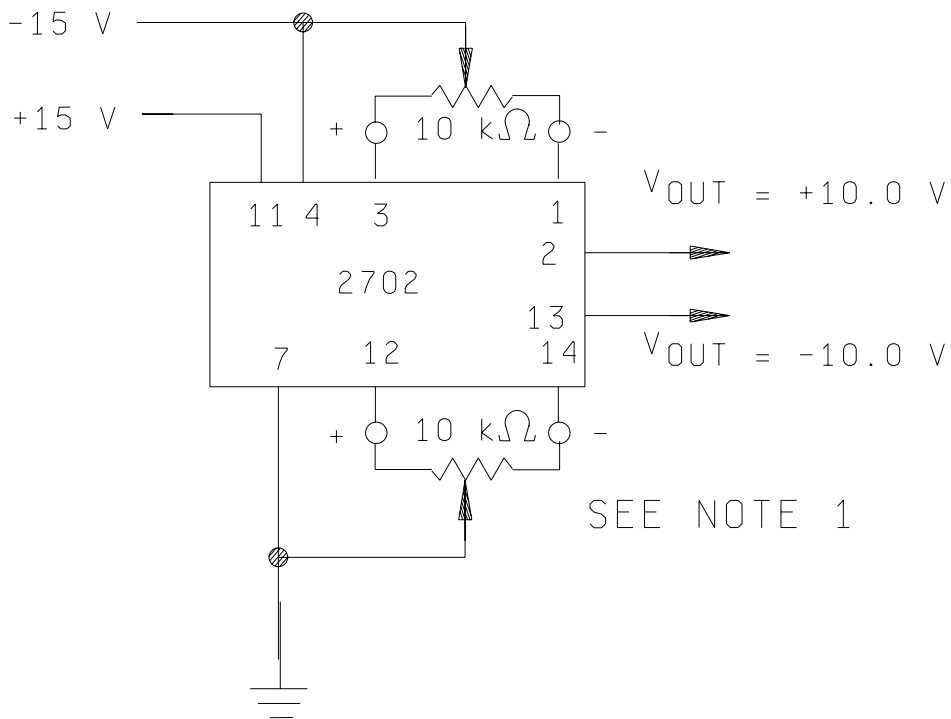

FIGURE 3. Trim circuit(s).

STANDARD  
MICROCIRCUIT DRAWING  
DEFENSE SUPPLY CENTER COLUMBUS  
COLUMBUS, OHIO 43216-5000

SIZE  
**A**

**85030**

REVISION LEVEL  
**F**

SHEET  
**13**

Device types 05 and 06.

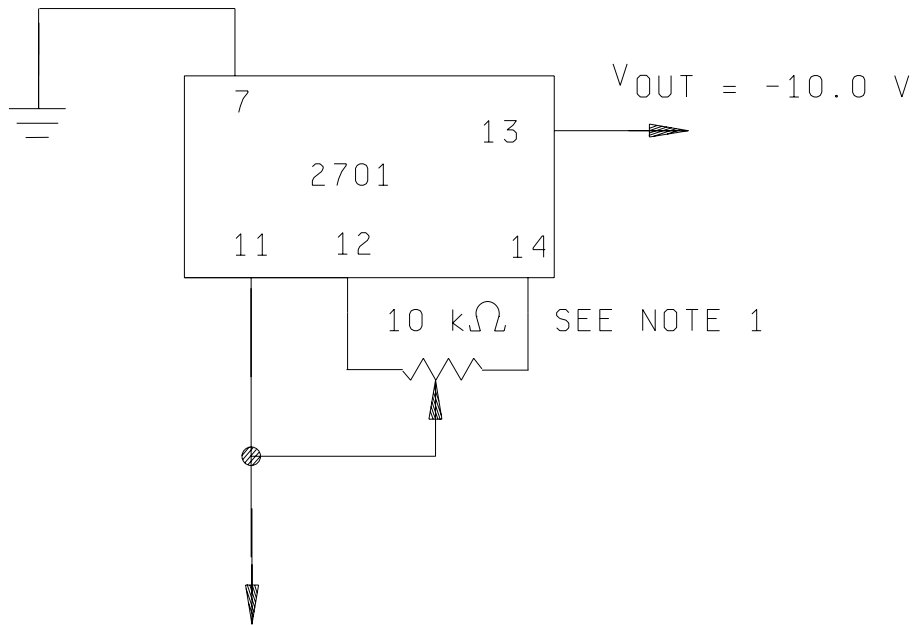

NOTES:

1. External 10 kΩ potentiometer provides a  $\pm 20$  mV minimum output offset adjust. Temperature effect is  $4 \mu V/^{\circ}C$  per mV of offset correction (external adjustment optional).
2. Dual-in-line package only.

FIGURE 3. Trim circuit(s) - Continued.

<b>STANDARD MICROCIRCUIT DRAWING DEFENSE SUPPLY CENTER COLUMBUS COLUMBUS, OHIO 43216-5000</b>	SIZE <b>A</b>		<b>85030</b>
		REVISION LEVEL <b>F</b>	SHEET <b>14</b>

TABLE II. Electrical test requirements.

MIL-PRF-38534 test requirements	Subgroups (in accordance with MIL-PRF-38534, group A test table)
Interim electrical parameters	----
Final electrical parameters	1*, 2, 3, 4
Group A test requirements	1, 2, 3, 4, 5, 6
Group C end-point electrical parameters	1

\* PDA applies to subgroup 1.

4.3 Conformance and periodic inspections. Conformance inspection (CI) and periodic inspection (PI) shall be in accordance with MIL-PRF-38534 and as specified herein.

4.3.1 Group A inspection (CI). Group A inspection shall be in accordance with MIL-PRF-38534 and as follows:

- a. Tests shall be as specified in table II herein.
- b. Subgroups 7, 8, 10, and 11 shall be omitted.

4.3.2 Group B inspection (PI). Group B inspection shall be in accordance with MIL-PRF-38534.

4.3.3 Group C inspection (PI). Group C inspection shall be in accordance with MIL-PRF-38534 and as follows:

- a. End-point electrical parameters shall be as specified in table II herein.
- b. Steady-state life test, method 1005 of MIL-STD-883.
  - (1) Test condition A, B, C, or D. The test circuit shall be maintained by the manufacturer under document revision level control and shall be made available to either DSCC-VA or the acquiring activity upon request. Also, the test circuit shall specify the inputs, outputs, biases, and power dissipation, as applicable, in accordance with the intent specified in test method 1005 of MIL-STD-883.
  - (2)  $T_A$  as specified in accordance with table I of method 1005 of MIL-STD-883.
  - (3) Test duration: 1,000 hours, except as permitted by method 1005 of MIL-STD-883.

4.3.4 Group D inspection (PI). Group D inspection shall be in accordance with MIL-PRF-38534.

<b>STANDARD MICROCIRCUIT DRAWING DEFENSE SUPPLY CENTER COLUMBUS COLUMBUS, OHIO 43216-5000</b>	<b>SIZE A</b>		<b>85030</b>
		<b>REVISION LEVEL F</b>	<b>SHEET 15</b>

5. PACKAGING

5.1 Packaging requirements. The requirements for packaging shall be in accordance with MIL-PRF-38534.

6. NOTES

6.1 Intended use. Microcircuits conforming to this drawing are intended for use for Government microcircuit applications (original equipment), design applications, and logistics purposes.

6.2 Replaceability. Microcircuits covered by this drawing will replace the same generic device covered by a contractor-prepared specification or drawing.

6.3 Configuration control of SMD's. All proposed changes to existing SMD's will be coordinated with the users of record for the individual documents. This coordination will be accomplished in accordance with MIL-STD-973 using DD Form 1692, Engineering Change Proposal.

6.4 Record of users. Military and industrial users shall inform Defense Supply Center Columbus when a system application requires configuration control and the applicable SMD. DSCC will maintain a record of users and this list will be used for coordination and distribution of changes to the drawings. Users of drawings covering microelectronic devices (FSC 5962) should contact DSCC-VA, telephone (614) 692-7603.

6.5 Comments. Comments on this drawing should be directed to DSCC-VA, P. O. Box 3990, Columbus, Ohio 43216-5000, or telephone (614) 692-0676.

6.6 Sources of supply. Sources of supply are listed in QML-38534. The vendors listed in QML-38534 have submitted a certificate of compliance (see 3.7 herein) to DSCC-VA and have agreed to this drawing.

<b>STANDARD MICROCIRCUIT DRAWING DEFENSE SUPPLY CENTER COLUMBUS COLUMBUS, OHIO 43216-5000</b>	<b>SIZE A</b>		<b>85030</b>
		<b>REVISION LEVEL F</b>	<b>SHEET 16</b>



STANDARD MICROCIRCUIT DRAWING SOURCE APPROVAL BULLETIN

DATE: 99-01-08

Approved sources of supply for SMD 85030 are listed below for immediate acquisition only and shall be added to QML-38534 during the next revision. QML-38534 will be revised to include the addition or deletion of sources. The vendors listed below have agreed to this drawing and a certificate of compliance has been submitted to and accepted by DSCC-VA. This bulletin is superseded by the next dated revision of QML-38534.

Standard microcircuit drawing PIN <u>1/</u>	Vendor CAGE number	Vendor similar PIN <u>2/</u>
8503001CA 8505001CC 8503001XX 8503001YA 8503001YC 8503001YX 8503001YA 85030013A	33256 33256 <u>3/</u> 33256 33256 <u>3/</u> 34707 34707	HS2700SD HS2700SD 2700SD/883B HS2700SD HS2700SD 2700SD/883B HC2700SD/883B HC2700SLCC/883B
8503002CA 8503002CC 8503002XX 8503002YA 8503002YC 8503002YX 8503002YA 85030023A	33256 33256 <u>3/</u> 33256 33256 <u>3/</u> 34707 34707	HS2700UD HS2700UD 2700UD/883B HS2700UD HS2700UD 2700UD/883B HC2700UD/883B HC2700ULCC/883B
8503003CA 8503003CC 8503003XX 8503003YA 8503003YC 8503003YX 8503003YA 85030033A	33256 33256 <u>3/</u> 33256 33256 <u>3/</u> 34707 34707	HS2702SD HS2702SD 2702SD/883B HS2702SD HS2702SD 2702SD/883B HC2702SD/883B HC2702SLCC/883B
8503004CA 8503004CC 8503004XX 8503004YA 8503004YC 8503004YX 8503004YA 85030043A	33256 33256 <u>3/</u> 33256 33256 <u>3/</u> 34707 34707	HS2702UD HS2702UD 2702UD/883B HS2702UD HS2702UD 2702UD/883B HC2702UD/883B HC2702ULCC/883B

- 1/ The lead finish shown for each PIN, representing a hermetic package, is the most readily available from the manufacturer listed for that part. If the desired lead finish is not listed contact the Vendor to determine availability.
- 2/ **Caution.** Do not use this number for item acquisition. Items acquired to this number may not satisfy the performance requirements of this drawing.
- 3/ Not available from a QML source.

STANDARD MICROCIRCUIT DRAWING SOURCE APPROVAL BULLETIN - Continued.

DATE: 99-01-08

Standard microcircuit drawing PIN <u>1/</u>	Vendor CAGE number	Vendor similar PIN <u>2/</u>
8503005CA	33256	HS2701SD
8503005CC	33256	HS2701SD
8503005XX	<u>3/</u>	2701SD/883B
8503005YA	33256	HS2701SD
8503005YC	33256	HS2701SD
8503005YA	34031	2701SD/883B
8503005YC	34031	2701SD/883B
8503005YA	34707	HC2701SD/883B
85030053A	34707	HC2701SLCC/883B
8503006CA	33256	HS2701UD
8503006CC	33256	HS2701UD
8503006XX	<u>3/</u>	2701UD/883B
8503006YA	33256	HS2701UD
8503006YC	33256	HS2701UD
8503006YA	34031	2701UD/883B
8503006YC	34031	2701UD/883B
8503006YA	34707	HC2701UD/883B
85030063A	34707	HC2701ULCC/883B

- 1/ The lead finish shown for each PIN, representing a hermetic package, is the most readily available from the manufacturer listed for that part. If the desired lead finish is not listed contact the Vendor to determine availability.
- 2/ **Caution.** Do not use this number for item acquisition. Items acquired to this number may not satisfy the performance requirements of this drawing.
- 3/ Not available from a QML source.

Vendor CAGE number

Vendor name and address

33256

Sipex Corporation  
Hybrid Systems Division  
22 Linnell Circle  
Billerica, CA 01821-3985

34031

Analog Devices, Incorporated  
7910 Triad Center Drive  
Greensboro, NC 27409-9605

34707

Hycomp, Incorporated  
165 Cedar Hill Street  
Marlborough, MA 01752-3035

The information contained herein is disseminated for convenience only and the Government assumes no liability whatsoever for any inaccuracies in this information bulletin.