

High Output Industrial VRS Magnetic Speed Sensors



DESCRIPTION

High Output VRS sensors are designed for use in applications where higher output voltages are needed. They perform best at low to medium speeds with medium to high impedance loads. Front-End Sealed versions are available for use where the sensor is exposed to fluids, lubricants or adverse environmental conditions.

Passive VRS (Variable Reluctance Speed) Magnetic Speed sensors are simple, rugged devices that do not require an external voltage source for operation.

A permanent magnet in the sensor establishes a fixed magnetic field. The approach and passing of a ferrous metal target near the sensor's pole piece (sensing area) changes the flux lines of the magnetic field, dynamically changing its strength. This change in magnetic field strength induces a current into a coil winding which is attached to the output terminals.

FEATURES

- Self-powered operation
- Direct conversion of actuator speed to output frequency
- Simple installation
- No moving parts
- Designed for use over a wide range of speeds
- Adaptable to a wide variety of configurations
- Customized VRS products for unique speed sensing applications
- Housing diameters: 5/8 in (M16), 3/8 in (M12)
- Housing materials/styles: stainless steel threaded or smooth
- Terminations: MS3106 connector, preleaded
- Output voltages: 8 Vp-p to 190 Vp-p

The output signal of a VRS sensor is an ac voltage that varies in amplitude and wave frequency as the speed of the monitored device changes, and is usually expressed in peak to peak voltage (Vp-p).

One complete waveform (cycle) occurs as each target passes the sensor's pole piece. If a standard gear were used as a target, this output signal would resemble a sine wave if viewed on an oscilloscope.

Honeywell also offers VRS sensors for general purpose, power output, high resolution, high temperature, and hazardous location applications, as well as low-cost molded versions.

POTENTIAL APPLICATIONS

- Engine RPM (revolutions per minute) measurement on aircraft, automobiles, boats, buses, trucks and rail vehicles
- Motor RPM measurement on drills, grinders, lathes and automatic screw machines
- Motor RPM measurement on precision camera, tape recording and motion picture equipment
- Process speed measurement on food, textile, paper, woodworking, printing, tobacco and pharmaceutical industry machinery
- Motor speed measurement of electrical generating equipment
- Speed measurement of pumps, blowers, mixers, exhaust and ventilating fans
- Flow measurement on turbine meters
- Wheel-slip measurement on autos and locomotives
- Gear speed measurement

High Output

5/8 INCH (M16*) SENSORS (All dimensions for reference only. mm/[in])

*Contact Honeywell for availability of metric mounting thread versions.

General Specifications

Parameter	Characteristic	Parameter	Characteristic
Min. output voltage	190 Vp-p	Inductance	450 mH max.
Coil resistance	910 Ohm to 1200 Ohm	Gear pitch range	24 DP (module 1.06) or coarser
Pole piece diameter	2,69 mm [0.106 in]	Optimum actuator	20 DP (module 1.27) ferrous metal gear
Min. surface speed	0,25 m/s [10 in/s] typ.	Max. operating frequency	15 kHz typ.
Operating temp. range	-55 °C to 120 °C [-67 °F to 250 °F]	Vibration	Mil-Std 202F Method 204D
Mounting thread	5/8-18 UNF-2A	Termination	MS3106 connector

Test Condition Specifications

Parameter	Characteristic
Surface speed	25 m/s [1000 in/s]
Gear	20 DP (module 1.27)
Air gap	0,127 mm [0.005 in]
Load resistance	100 kOhm

Catalog Listing	Thread Length (A)	Weight	Diagram	
3030AN	28 mm [1.1 in]	70 g [2.5 oz]		
3030AN25	63 mm [2.5 in]	84 g [3.0 oz]		
3030AN30	76 mm [3.0 in]	84 g [3.0 oz]		
3030AN40	101 mm [4.0 in]	98 g [3.5 oz]		
3030AN50	127 mm [5.0 in]	128 g [4.5 oz]		

General Specifications

Parameter	Characteristic	Parameter	Characteristic
Min. output voltage	190 Vp-p	Inductance	450 mH max.
Coil resistance	910 Ohm to 1200 Ohm	Gear pitch range	24 DP (module 1.06) or coarser
Pole piece diameter	2,69 mm [0.106 in]	Optimum actuator	20 DP (module 1.27) ferrous metal gear
Min. surface speed	0,25 m/s [10 in/s] typ.	Max. operating frequency	15 kHz typ.
Operating temp. range	-55 °C to 120 °C [-67 °F to 250 °F]	Vibration	Mil-Std 202F Method 204D
Mounting thread	5/8-18 UNF-2A	Termination	20 AWG Teflon-insulated Leads

Test Condition Specifications

Parameter	Characteristic
Surface speed	25 m/s [1000 in/s]
Gear	20 DP (module 1.27)
Air gap	0,127 mm [0.005 in]
Load resistance	100 kOhm

Catalog Listing	Thread Length (A)	Weight	Diagram
3030S20	50 mm [2.0 in]	70 g [2.5 oz]	
3030S30	76 mm [3.0 in]	84 g [3.0 oz]	

Industrial VRS Magnetic Speed Sensors

5/8 INCH (M16*) SENSORS CONTINUED (All dimensions for reference only. mm/[in])

*Contact Honeywell for availability of metric mounting thread versions.

General Specifications

Parameter	Characteristic	Parameter	Characteristic
Min. output voltage	190 Vp-p	Inductance	450 mH max.
Coil resistance	910 Ohm to 1200 Ohm	Gear pitch range	24 DP (module 1.06) or coarser
Pole piece diameter	2,69 mm [0.106 in]	Optimum actuator	20 DP (module 1.27) ferrous metal gear
Min. surface speed	0,25 m/s [10 in/s] typ.	Max. operating frequency	15 kHz typ.
Operating temp. range	-55 °C to 120 °C [-67 °F to 250 °F]	Vibration	Mil-Std 202F Method 204D
Mounting thread	5/8-18 UNF-2A	Termination	20 AWG Teflon-insulated leads

Test Condition Specifications

Parameter	Characteristic
Surface speed	25 m/s [1000 in/s]
Gear	20 DP (module 1.27)
Air gap	0,127 mm [0.005 in]
Load resistance	100 kOhm

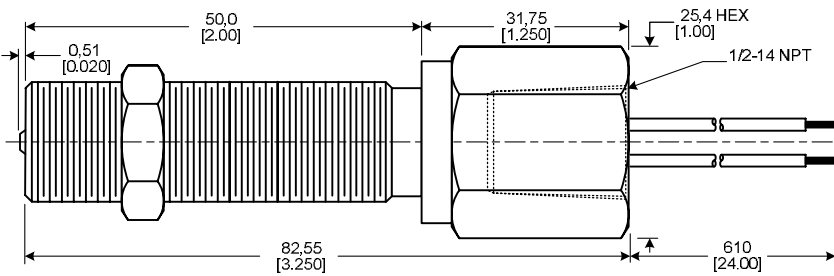
Catalog Listing	Weight	
3030H20	140 g [5.0 oz]	

General Specifications

Parameter	Characteristic	Parameter	Characteristic
Min. output voltage	190 Vp-p	Inductance	450 mH max.
Coil resistance	910 Ohm to 1200 Ohm	Gear pitch range	24 DP (module 1.06) or coarser
Pole piece diameter	2,69 mm [0.106 in]	Optimum actuator	20 DP (module 1.27) ferrous metal gear
Min. surface speed	0,25 m/s [10 in/s] typ.	Max. operating frequency	15 kHz typ.
Operating temp. range	-55 °C to 120 °C [-67 °F to 250 °F]	Vibration	Mil-Std 202F Method 204D
Mounting thread	5/8-18 UNF-2A	Termination	MS3106 connector

Test Condition Specifications

Parameter	Characteristic
Surface speed	25 m/s [1000 in/s]
Gear	20 DP (module 1.27)
Air gap	0,127 mm [0.005 in]
Load resistance	100 kOhm

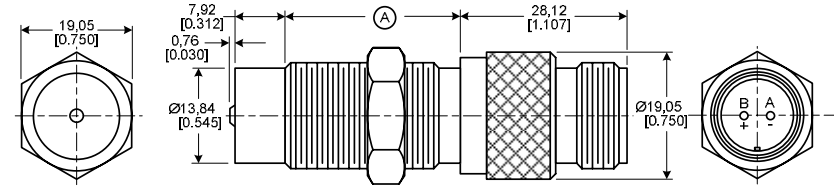
Catalog Listing	Thread Length (A)	Weight	
3030A	35 mm 1.4 in]	70 g [2.5 oz]	
3030A25	63 mm [2.5 in]	84 g [3.5 oz]	

High Output

5/8 INCH (M16*) SEALED FRONT-END SENSORS (All dimensions for reference only. mm/[in])

*Contact Honeywell for availability of metric mounting thread versions.

HIGH RESISTANCE COILS FOR MAXIMUM OUTPUT VOLTAGE APPLICATIONS

General Specifications

Parameter	Characteristic	Parameter	Characteristic
Min. output voltage	175 Vp-p	Inductance	450 mH max.
Coil resistance	910 to 1200 Ohm	Gear pitch range	24 DP (module 1.06) ferrous metal gear
Pole piece diameter	2,69 mm [0.106 in]	Optimum actuator	--
Minimum surface speed	0,25 m/s [10 in/s] typ.	Maximum operating frequency	15 kHz typ.
Operating temp. range	-55 °C to 150 °C [-67 °F to 300 °F]	Vibration	Mil-Std 202F Method 204D
Mounting thread	5/8-18 UNF-2A	Termination	MS3106 connector

Test Condition Specifications

Parameter	Characteristic
Surface speed	25 m/s [1000 in/s]
Gear	20 DP (module 1.27)
Air gap	0,127 mm [0.005 in]
Load resistance	100 kOhm

Catalog Listing	Thread Length (A)	Weight	Diagram	
MA230SAN	28 mm [1.1 in]	70 g [2.0 oz]		
MA233SAN	76 mm [3.0 in]	98 g [3.5 oz]		

Industrial VRS Magnetic Speed Sensors

5/8 INCH (M16*) SEALED FRONT-END SENSORS (All dimensions for reference only. mm/[in])

*Contact Honeywell for availability of metric mounting thread versions.

NOMINAL RESISTANCE COILS FOR LOW IMPEDANCE LOAD APPLICATIONS

General Specifications

Parameter	Characteristic	Parameter	Characteristic
Min. output voltage	60 Vp-p	Inductance	85 mH max.
Coil resistance	120 to 162 Ohm	Gear pitch range	12 DP (module 2.11) ferrous metal gear
Pole piece diameter	4,39 mm [0.173 in]	Optimum actuator	N/A
Minimum surface speed	0,38 m/s [15 in/s] typ.	Maximum operating frequency	40 kHz typ.
Operating temp. range	-55 °C to 150 °C [-67 °F to 300 °F]	Vibration	Mil-Std 202F Method 204D
Mounting thread	5/8-18 UNF-2A	Termination	MS3106 connector

Test Condition Specifications

Parameter	Characteristic
Surface speed	25 m/s [1000 in/s]
Gear	8 DP (module 3.17)
Air gap	0,127 mm [0.005 in]
Load resistance	1.25 kOhm

Catalog Listing	Thread Length (A)	Weight	Diagram	
MA240SAN	28 mm [1.1 in]	70 g [2.0 oz]		
MA243SAN	76 mm [3.0 in]	98 g [3.5 oz]		

High Output

3/8 INCH (M12*) SENSORS (All dimensions for reference only. mm/[in])

*Contact Honeywell for availability of metric mounting thread versions.

General Specifications

Parameter	Characteristic	Parameter	Characteristic
Min. output voltage	55 Vp-p	Inductance	75 mH max.
Coil resistance	275 Ohm to 330 Ohm	Gear pitch range	26 DP (module 0.98) or coarser
Pole piece diameter	2,36 mm [0.093 in]	Optimum actuator	24 DP (module 1.06) ferrous metal gear
Minimum surface speed	0,38 m/s [15 in/s] typ.	Maximum operating frequency	40 kHz typ.
Operating temp. range	-40 °C to 107 °C [-40 °F to 225 °F]	Vibration	Mil-Std 202F Method 204D
Mounting thread	3/8-24 UNF-2A	Termination	24 AWG, vinyl-insulated leads

Test Condition Specifications

Parameter	Characteristic
Surface speed	25 m/s [1000 in/s]
Gear	20 DP (module 1.27)
Air gap	0,127 mm [0.005 in]
Load resistance	100 kOhm

Catalog Listing	Thread Length (A)	Weight	
3025A	20 mm [0.8 in]	28 g [1.0 oz]	
3020A17	44 mm [1.7 in]	35 g [1.2 oz]	
3020A35	88 mm [3.5 in]	42 g [1.5 oz]	

Catalog Listing	Thread Length (A)	Weight	
3025S13	30 mm [1.2 in]	28 g [1.0 oz]	

Industrial VRS Magnetic Speed Sensors

3/8 (M12*) SENSORS CONTINUED (All dimensions for reference only. mm/[in])

*Contact Honeywell for availability of metric mounting thread versions.

General Specifications

Parameter	Characteristic	Parameter	Characteristic
Min. output voltage	55 Vp-p	Inductance	75 mH max.
Coil resistance	275 Ohm to 330 Ohm	Gear pitch range	26 DP (module 0.98) or coarser
Pole piece diameter	2,36 mm [0.093 in]	Optimum actuator	24 DP (module 1.06) ferrous metal gear
Minimum surface speed	0,38 m/s [15 in/s] typ.	Maximum operating frequency	40 kHz typ.
Operating temp. range	-40 °C to 107 °C [-40 °F to 225 °F]	Vibration	Mil-Std 202F Method 204D
Mounting thread	3/8-24 UNF-2A	Termination	24 AWG, PVC-insulated leads

Test Condition Specifications

Parameter	Characteristic
Surface speed	25 m/s [1000 in/s]
Gear	20 DP (module 1.27)
Air gap	0,127 mm [0.005 in]
Load resistance	100 kOhm

Catalog Listing	Barrel Length (A)	Weight	
3025SS13	30 mm [1.2 in]	28 g [1.0 oz]	
3025SS23	63 mm [2.5 in]	42 g [1.5 oz]	

WARNING

PERSONAL INJURY

DO NOT USE these products as safety or emergency stop devices or in any other application where failure of the product could result in personal injury.

Failure to comply with these instructions could result in death or serious injury.

WARRANTY/REMEDY

Honeywell warrants goods of its manufacture as being free of defective materials and faulty workmanship. Honeywell's standard product warranty applies unless agreed to otherwise by Honeywell in writing; please refer to your order acknowledgement or consult your local sales office for specific warranty details. If warranted goods are returned to Honeywell during the period of coverage, Honeywell will repair or replace, at its option, without charge those items it finds defective. **The foregoing is buyer's sole remedy and is in lieu of all other warranties, expressed or implied, including those of merchantability and fitness for a particular purpose. In no event shall Honeywell be liable for consequential, special, or indirect damages.**

While we provide application assistance personally, through our literature and the Honeywell web site, it is up to the customer to determine the suitability of the product in the application.

Specifications may change without notice. The information we supply is believed to be accurate and reliable as of this printing. However, we assume no responsibility for its use.

WARNING

MISUSE OF DOCUMENTATION

- The information presented in this product sheet is for reference only. Do not use this document as a product installation guide.
- Complete installation, operation, and maintenance information is provided in the instructions supplied with each product.

Failure to comply with these instructions could result in death or serious injury.

SALES AND SERVICE

Honeywell serves its customers through a worldwide network of sales offices, representatives and distributors. For application assistance, current specifications, pricing or name of the nearest Authorized Distributor, contact your local sales office or:

E-mail: info.sc@honeywell.com

Internet: www.honeywell.com/sensing

Phone and Fax:

Asia Pacific +65 6355-2828
+65 6445-3033 Fax
Europe +44 (0) 1698 481481
+44 (0) 1698 481676 Fax
Latin America +1-305-805-8188
+1-305-883-8257 Fax
USA/Canada +1-800-537-6945
+1-815-235-6847
+1-815-235-6545 Fax

Automation and Control Solutions

Sensing and Control

Honeywell

1985 Douglas Drive North

Minneapolis, MN 55422

www.honeywell.com/sensing

005876-1-EN IL50 GLO Printed in USA
March 2007

Copyright © 2007 Honeywell International Inc. All rights reserved.

Honeywell