

4

3

2

1

THIS DRAWING IS UNPUBLISHED. RELEASED FOR PUBLICATION
 © COPYRIGHT - TE Connectivity Ltd. ALL RIGHTS RESERVED.

REVISIONS				
P	LTR	DESCRIPTION	DATE	APVD
E		REV PER EC 0020-250-94	03/24/94	AT
F		REV PER EC 0020-250-94	20FEB2020	RK MZ

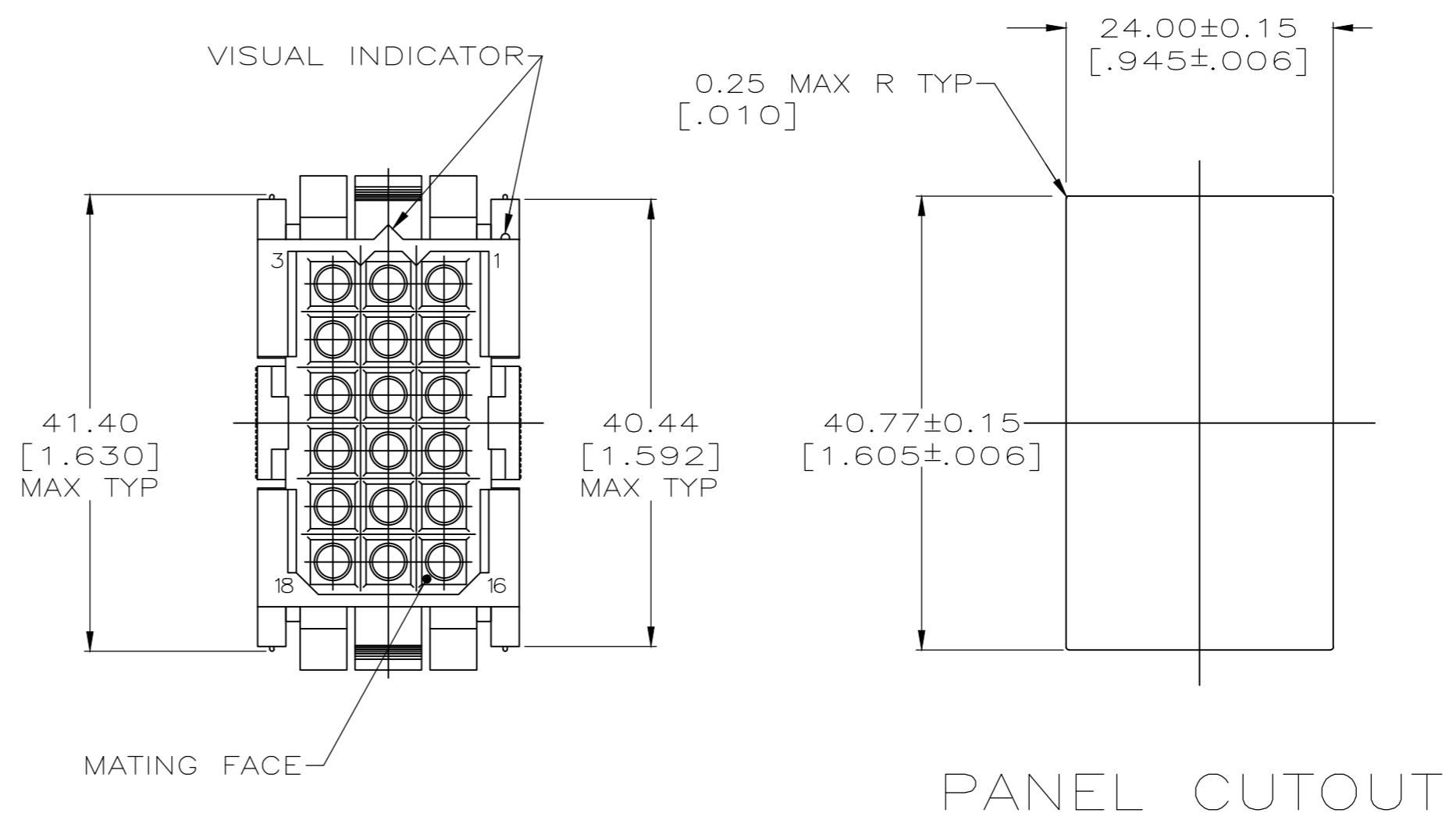
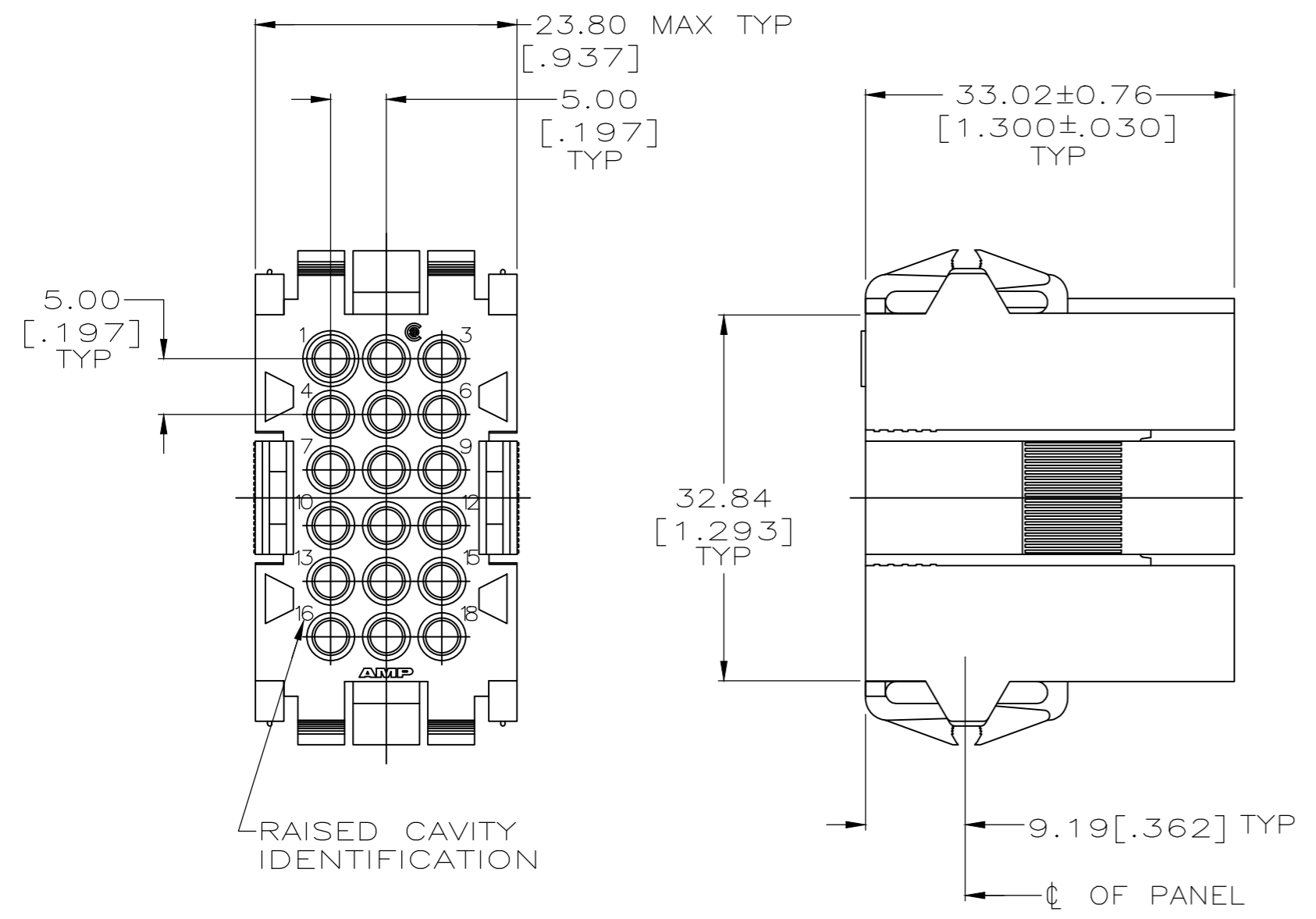

- 1. PANEL RETENTION MECHANISM ACCOMMODATES PANEL THICKNESSES FROM 0.76[.030] TO 2.29[.090].
- 2 HOUSING MATERIAL: PA66, BLACK, UL 94 V-0 RATED.

207443-1
 PART NUMBER

THIS DRAWING IS A CONTROLLED DOCUMENT.		DWN W.LENKER 08/26/92	TE Connectivity HOUSING, RECEPTACLE, 18 POSITION, METRIMATE	
DIMENSIONS: mm [INCHES]		CHK R.STONE 8-31-92		
TOLERANCES UNLESS OTHERWISE SPECIFIED:		APVD A.TRAVIS 9-2-92	NAME 108-10033	
0 PLC ± - 1 PLC ± - 2 PLC ± 0.25 [.010] 3 PLC ± - 4 PLC ± - ANGLES ± -		PRODUCT SPEC APPLICATION SPEC		RESTRICTED TO
MATERIAL 2		FINISH -	WEIGHT -	SIZE A2
		CAGE CODE 00779		DRAWING NO 207443
		CUSTOMER DRAWING		SCALE 2:1 SHEET 1 OF 1 REV F

207443
B