

LOC		DIST		REVISIONS			
P	LTR	DESCRIPTION	DATE	DNW	APVD		
T		REV PER ECO-15-016062	09NOV15	KG	CD		

1. THIS RCPT. IS DESIGNED TO CONFORM TO THE LATEST ISSUE OF MIL-C-24308.
2. MAX WIRE INSUL TO BE USED WITH THIS RCPT. IS $\phi.054$.
3. METAL RETENTION CLIPS ARE INCLUDED IN INSERTS.
4. PACKAGE STAMPED M 24308/2-287F.
5. THIS RCPT. WILL ACCEPT SIZE 22 SOCKET CONTACT M 39029/57-354 OR ANY TYCO HDD-22 SOCKET CONTACT.
6. MFG'S PART NO. STAMPED ON CONNECTOR REPRESENTS KIT NUMBER WITH CONTACTS.
7. UL/CSA DESIGNATION STAMPED ON SHELL.
8. 204514 INK STAMPED, NEAR SIDE. M24308/2-12F INK STAMPED, FAR SIDE.
9. 204502-4 INK STAMPED, NEAR SIDE.
10. FINISH: BRIGHT TIN PER ASTM-B-545, .000400-.000550 THK OVER COPPER PER AMS2418, .000050 MIN THK.

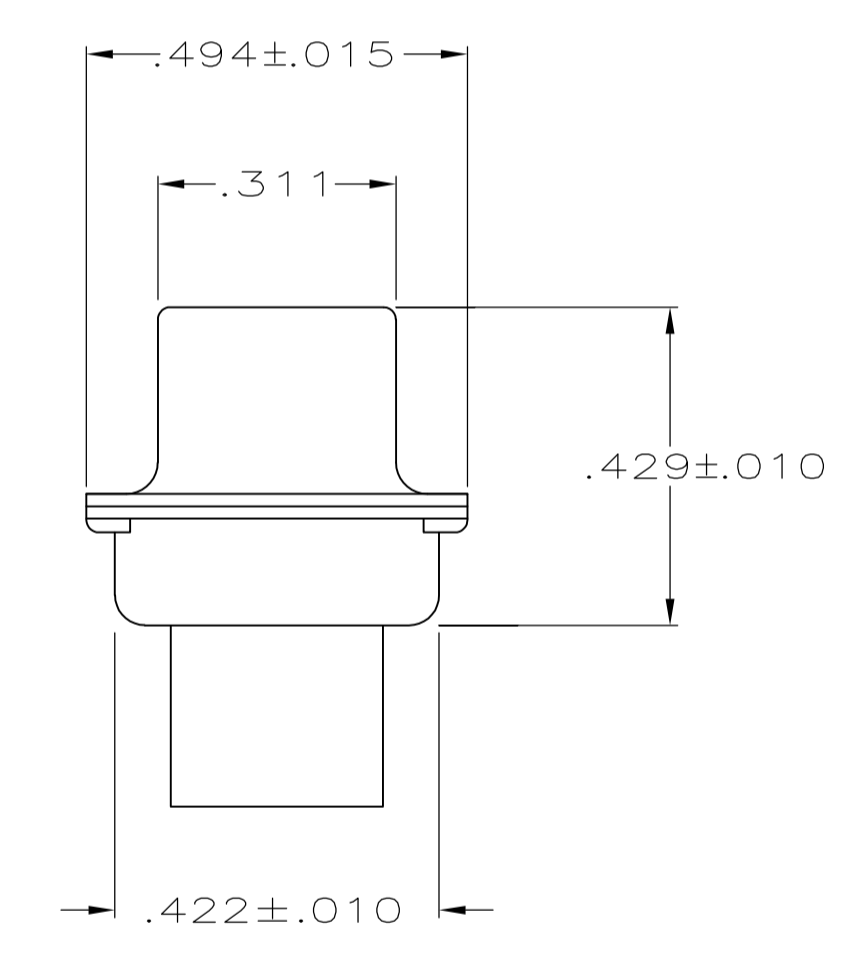
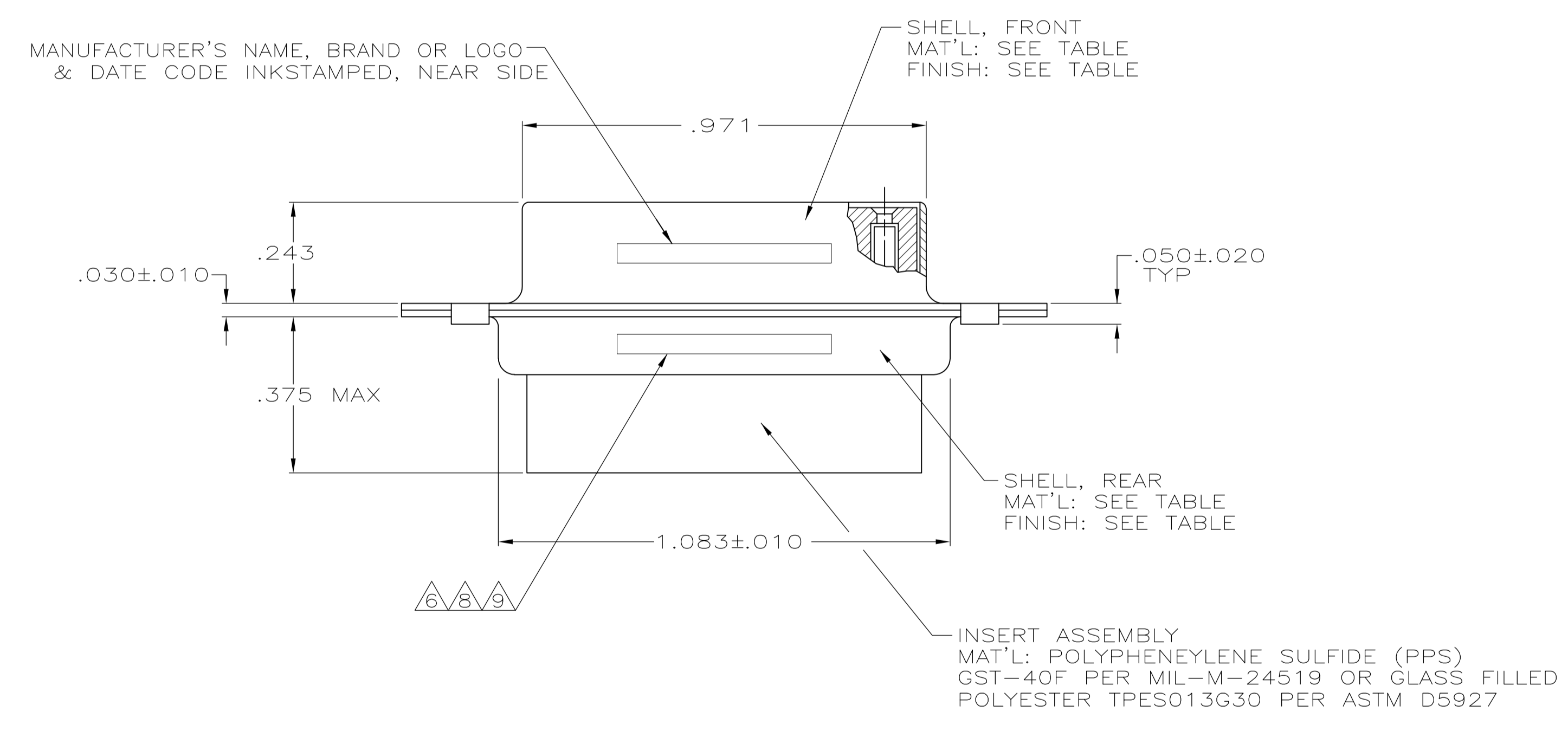
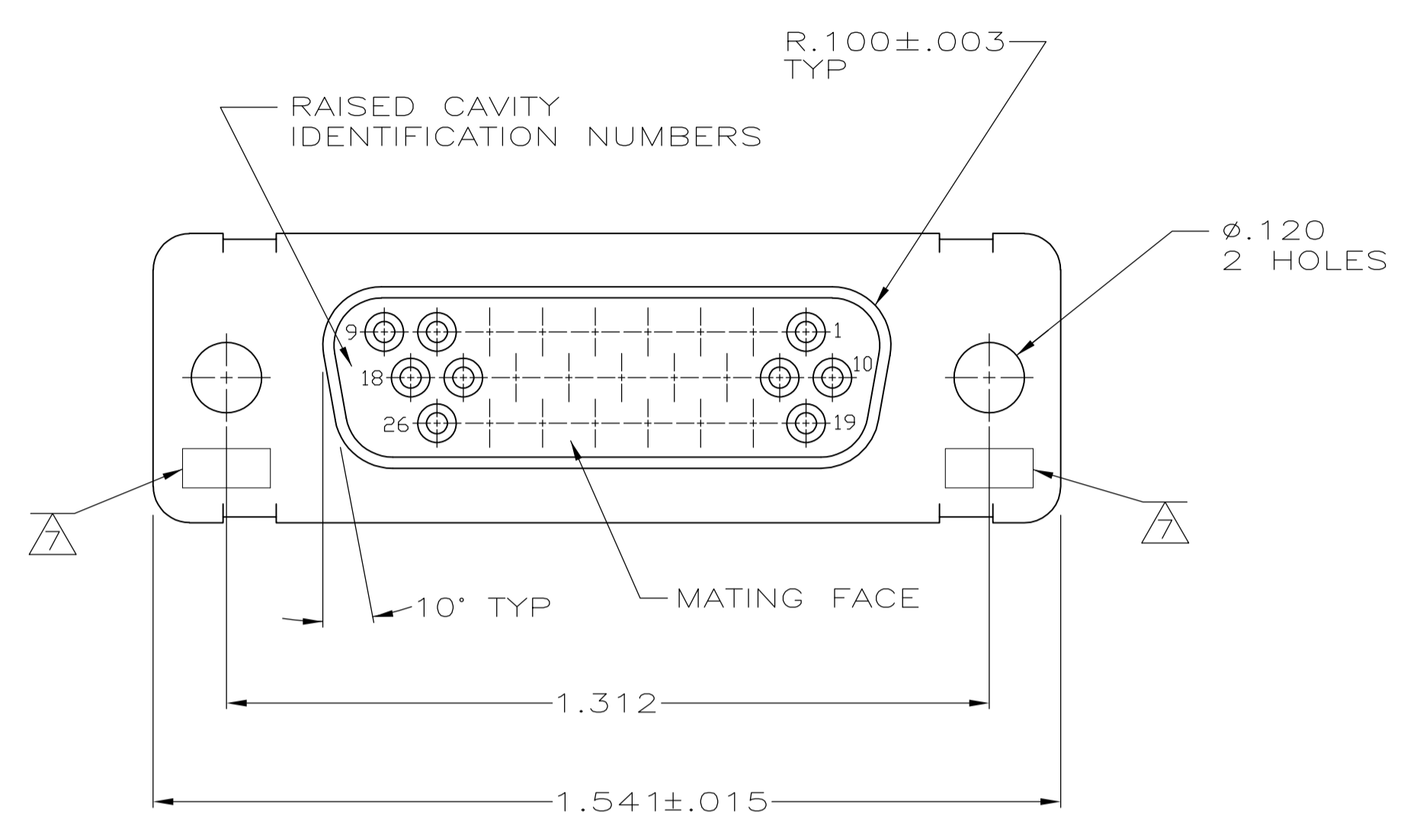

REMARKS	FINISH	SHELL MATERIAL	PART NO.
SUPSD BY 204502-1	9	STEEL, CLASS G	204502-4
SUPSD BY 206501-4	10	STEEL, CLASS G	204502-3
		BRASS	204502-2
	4, 6, 8	STEEL, CLASS G	204502-1

THIS DRAWING IS A CONTROLLED DOCUMENT.

DIMENSIONS: INCHES	TOLERANCES UNLESS OTHERWISE SPECIFIED:	DIN C.C.THOMAS 01-DEC-87	APVD F.C.BALLEW 25-JAN-88	NAME	AMPLIMITE RCPT. FOR SOCKET CONTACTS HI-DENSITY D CONNECTOR SIZE 2 (26 POSN) SERIES 90
0 PLC ± -	1 PLC ± -	2 PLC ± -	3 PLC ± .005	4 PLC ± -	ANGLES ± 0'30"
MATERIAL SEE TABLE	FINISH SEE TABLE	WEIGHT -	SIZE A1	SCALE 4:1	SHEET 1 OF 1

STE TE Connectivity

CUSTOMER DRAWING