

**RIGHT ANGLE PLUG CLAMP TYPE
CABLE 5/50 S+D**

R161.157.000
SERIES N

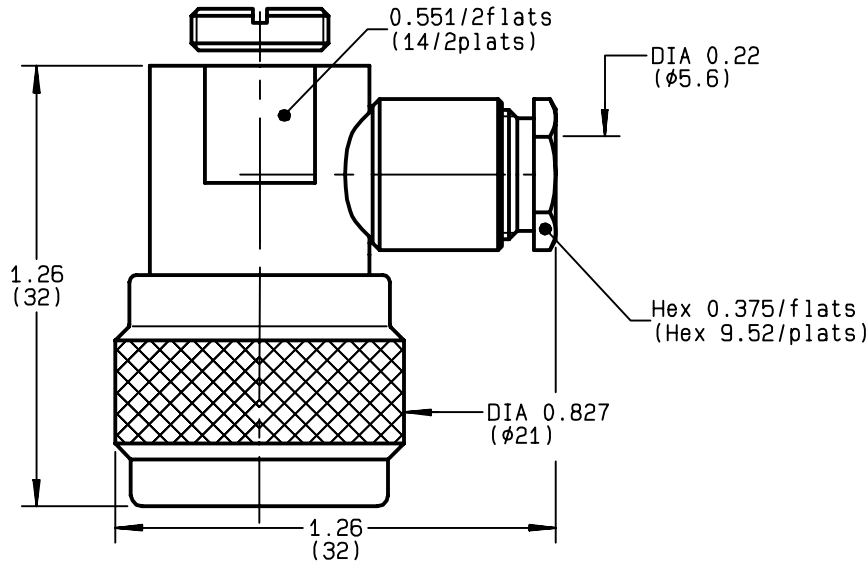

NOMINAL IMPEDANCE	50 Ω	CABLES : KX 15 KX 23 RG 141 RG 142 RG 142 FTX RG 223 RG 400 RG 58
FREQUENCY RANGE	0-11 GHz	
TEMPERATURE RATING	-55/+155 °C	
V.S.W.R	1.50 + x F(GHz)Maxi	
RF INSERTION LOSS	0.07 √F(GHz) dB Maxi	
VOLTAGE RATING	850 Veff Maxi	
DIELECTRIC WITHSTANDING VOLTAGE	1500 Veff Mini	
INSULATION RESISTANCE	5000 MΩMini	
HERMETIC SEAL	NA Atm.cm ³ /s	
LEAKAGE (pressurized only)	NA	
MECHANICAL DURABILITY	500 Cycles	OTHERS CHARACTERISTICS CABLE RETENTION 150 N Mini CENTER CONTACT RETENTION Axial force - mating end 27 N Mini Axial force - opposite end 27 N Mini Torque NA cm.N Mini RECOMMENDED TORQUES Mating 130 cm.N Panel nut NA cm.N Clamp nut 150 cm.N
WEIGHT	80 gr	
SPECIFICATION		

CONNECTOR PARTS	MATERIALS	FINISH	(all values are given) in micrometers
BODY	BRASS	BBR 2	
OUTER CONTACT	BRASS	BBR 2	
CENTER CONTACT	BRASS	GOLD 0.5 OVER NICKEL 2	
INSULATOR	PTFE	-	
GASKET	SILICONE RUBBER	-	
OTHERS PIECES	BRASS	BBR 2	

ISSUE	CREATION DATE	FILE PART-NUMBER
9812J01	30/06/1993	EPC 96-07



BONMINI

The information given here is subject to change without notice.
Design changes may be in order to improve the product .

Connect to the future



R161.157.000

ISSUE **9812J01** SERIES **N**

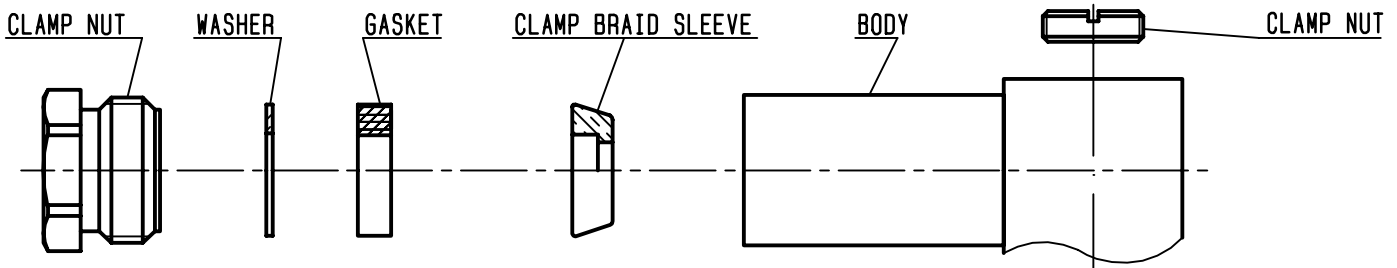

①

Strip the cable .

-
-
-
-

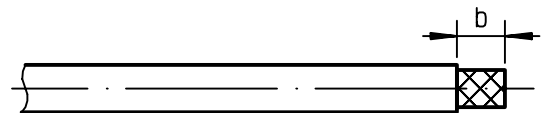

Stripping	a	b	c	d	e
inch	0.138	0.453	0	0	0.276
mm	3.5	11.5			7

②

Slide the clamp nut , the washer and the gasket onto the cable .

Slide clamp braid sleeve over braid .
Fold back braid and trim off surplus braid .

Trim back dielectric as shown .

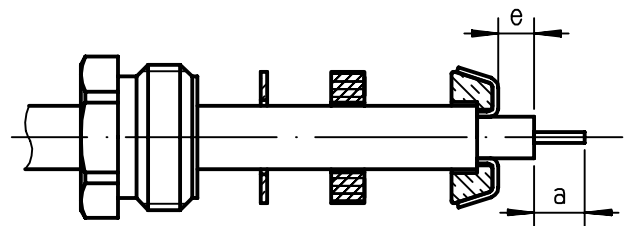

③

Screw sub-assembly into the connector body .

(recommended coupling torque 13.27 in.lb)

-

Solder center contact .

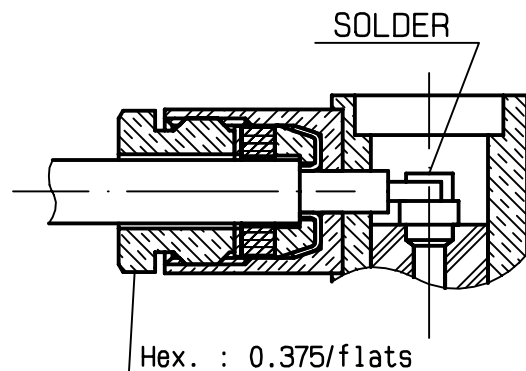

④

Screw clamp nut into the body .

-
-
-
-

