

REVISIONS					
P	LTR	DESCRIPTION	DATE	DN	APVD
J2	REVISED PER	ECN-22-155203	23MAY2022	RK	MF

- 1 POINT OF MEASUREMENT FOR PLATING THICKNESS
- 2 ASSEMBLIES MAY BE BROKEN TO THE DESIRED NUMBER OF POSITIONS
- 3 TRUE POSITION TOLERANCE OF THE POST TIPS APPLIES WHEN THE HEADERS ARE HELD FLAT AGAINST THE PRINTED CIRCUIT BOARD
- 4 .000030 GOLD ON THE CONTACT AREA, .000100-.000200 MATTE TIN-LEAD ON THE SOLDER TAIL, ALL OVER .000050 NICKEL
- 5 BREAKAWAY NOTCH ANGLE CAN BE ORIENTED TO THE RIGHT (AS SHOWN) OR TO THE LEFT
- 6 .000030 GOLD ON THE CONTACT AREA, .000100-.000200 MATTE TIN ON THE SOLDER TAIL, ALL OVER .000050 NICKEL
- 7 HIGH TEMPERATURE CONFIGURATION
- 8 OBSOLETE PARTS: OBSOLETE CIS STREAMLINING PER D.RENAUD/D.SINISI
- 9 OBSOLETE

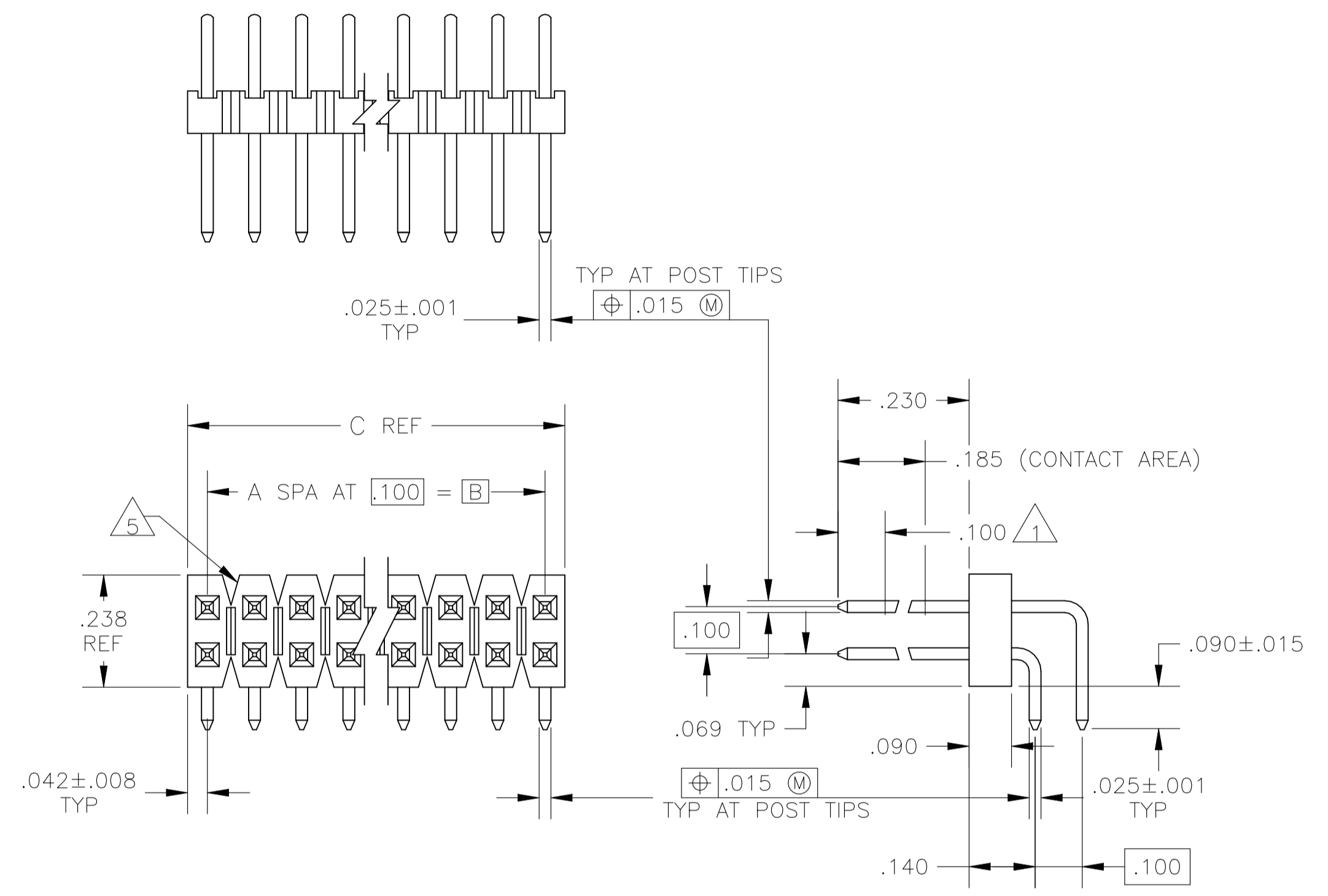

7	6	3.984	3.900	39	80	9-103801-0	7	6	3.984	3.900	39	80	4-103801-0
7	6	3.884	3.800	38	78	8-103801-9	7	6	3.884	3.800	38	78	3-103801-9
7	6	3.784	3.700	37	76	8-103801-8	7	6	3.784	3.700	37	76	3-103801-8
7	6	3.684	3.600	36	74	8-103801-7	7	6	3.684	3.600	36	74	3-103801-7
7	6	3.584	3.500	35	72	8-103801-6	7	6	3.584	3.500	35	72	3-103801-6
7	6	3.484	3.400	34	70	8-103801-5	7	6	3.484	3.400	34	70	3-103801-5
7	6	3.284	3.300	33	68	8-103801-4	7	6	3.284	3.300	33	68	3-103801-4
7	6	3.284	3.200	32	66	8-103801-3	7	6	3.284	3.200	32	66	3-103801-3
7	6	3.184	3.100	31	64	8-103801-2	7	6	3.184	3.100	31	64	3-103801-2
7	6	3.084	3.000	30	62	8-103801-1	7	6	3.084	3.000	30	62	3-103801-1
7	6	2.984	2.900	29	60	3-103801-0	7	6	2.984	2.900	29	60	3-103801-0
7	6	2.884	2.800	28	58	7-103801-9	7	6	2.884	2.800	28	58	2-103801-9
7	6	2.784	2.700	27	56	7-103801-8	7	6	2.784	2.700	27	56	2-103801-8
7	6	2.684	2.600	26	54	7-103801-7	7	6	2.684	2.600	26	54	2-103801-7
7	6	2.584	2.500	25	52	7-103801-6	7	6	2.584	2.500	25	52	2-103801-6
7	6	2.484	2.400	24	50	7-103801-5	7	6	2.484	2.400	24	50	2-103801-5
7	6	2.384	2.300	23	48	7-103801-4	7	6	2.384	2.300	23	48	2-103801-4
7	6	2.284	2.200	22	46	7-103801-3	7	6	2.284	2.200	22	46	2-103801-3
7	6	2.184	2.100	21	44	7-103801-2	7	6	2.184	2.100	21	44	2-103801-2
7	6	2.084	2.000	20	42	7-103801-1	7	6	2.084	2.000	20	42	2-103801-1
7	6	1.984	1.900	19	40	7-103801-0	7	6	1.984	1.900	19	40	2-103801-0
7	6	1.884	1.800	18	38	6-103801-9	7	6	1.884	1.800	18	38	1-103801-9
7	6	1.784	1.700	17	36	6-103801-8	7	6	1.784	1.700	17	36	1-103801-8
7	6	1.684	1.600	16	34	6-103801-7	7	6	1.684	1.600	16	34	1-103801-7
7	6	1.584	1.500	15	32	6-103801-6	7	6	1.584	1.500	15	32	1-103801-6
7	6	1.484	1.400	14	30	6-103801-5	7	6	1.484	1.400	14	30	1-103801-5
7	6	1.384	1.300	13	28	6-103801-4	7	6	1.384	1.300	13	28	1-103801-4
7	6	1.284	1.200	12	26	6-103801-3	7	6	1.284	1.200	12	26	1-103801-3
7	6	1.184	1.100	11	24	6-103801-2	7	6	1.184	1.100	11	24	1-103801-2
7	6	1.084	1.000	10	22	6-103801-1	7	6	1.084	1.000	10	22	1-103801-1
7	6	.984	.900	9	20	6-103801-0	7	6	.984	.900	9	20	1-103801-0
7	6	.884	.800	8	18	5-103801-9	7	6	.884	.800	8	18	103801-9
7	6	.784	.700	7	16	5-103801-8	7	6	.784	.700	7	16	103801-8
7	6	.684	.600	6	14	5-103801-7	7	6	.684	.600	6	14	103801-7
7	6	.584	.500	5	12	5-103801-6	7	6	.584	.500	5	12	103801-6
7	6	.484	.400	4	10	5-103801-5	7	6	.484	.400	4	10	103801-5
7	6	.384	.300	3	8	5-103801-4	7	6	.384	.300	3	8	103801-4
7	6	.284	.200	2	6	5-103801-3	7	6	.284	.200	2	6	103801-3
7	6	.184	.100	1	4	5-103801-2	7	6	.184	.100	1	4	103801-2
7	6	.084			2	5-103801-1	7	6	.084			2	103801-1

REMARKS	PLATING	C	B	A	NO OF POS	ASSEMBLY PART NUMBER	REMARKS	PLATING	C	B	A	NO OF POS	ASSEMBLY PART NUMBER
---------	---------	---	---	---	-----------	----------------------	---------	---------	---	---	---	-----------	----------------------

THIS DRAWING IS A CONTROLLED DOCUMENT.

DIN L. D. RINGLEY 31-7-85  
CHK R. FLICKER 31-7-85

APVD R. FLICKER 31-7-85

NAME: ASSY, MOD II, HDR, B/A, DR, RIGHT ANGLE, .100X.100 C/L, WITH .025 SQUARE POSTS

PRODUCT SPEC: APPLICATION SPEC

SIZE: A1

SCALE: 4:1

SHEET 1 of 1

REV J2

CUSTOMER DRAWING

SCALE: 4:1

SHEET 1 of 1

REV J2