



3.3V Single and Dual Axis Automotive *i*MEMS[®] Accelerometers

AD22300, AD22301, AD22302

FEATURES

- Complete Acceleration Measurement System on a Single Monolithic IC
- $\pm 35g$, $\pm 70g$ and $\pm 70g/\pm 35g$ Ranges Available
- Smallest Available Package Footprint For Automotive Safety Applications
- 8 pin Leadless Chip Carrier
- Full Differential Sensor & Circuitry for High Resistance to EMI/RFI
- Environmentally robust packaging
- Complete Mechanical and Electrical Self-test on Digital Command
- Output Ratiometric to Supply
- Sensitive Axes in the Plane of the Chip
- High Linearity (0.2% of Full-scale)
- Frequency Response Down To DC
- Supply Voltage (3.3V)
- Low-Power Consumption (1.3 mA single and dual axis)
- Tight Sensitivity Tolerance and Zero g Offset capability
- Higher Output Drive Current
- Largest available pre-filter clipping headroom
- 400 Hz, 2 pole Bessel Filter



GENERAL DESCRIPTION

The AD22300, AD22301, and AD22302 are derivative products of the fourth generation ADXL78 family surface micromachined *i*MEMS[®] accelerometers from Analog Devices with enhanced performance and lower cost. Designed for use in airbag applications, these products also provide complete cost-effective solutions useful for a wide variety of other applications.

The AD22300 and AD22301 are single-axis accelerometers with *g*-ranges of $\pm 37g$ or $\pm 70g$. The AD22302 is a monolithic two-axis (XY) version with the sensor axes orthogonal (90°) to each other and in the plane of the chip. The AD22302 X-axis has a *g*-range of $\pm 70g$ and its Y-axis has a *g*-range of $\pm 37g$. It can be used for sensing crashes in the front or side of the vehicle and to determine the angle of impact.

The AD22300, AD22301, and AD22302 are temperature stable and accurate over the automotive temperature range, with a self-test feature that fully exercises all the mechanical and electrical elements of the sensor with a digital signal applied to a single pin.

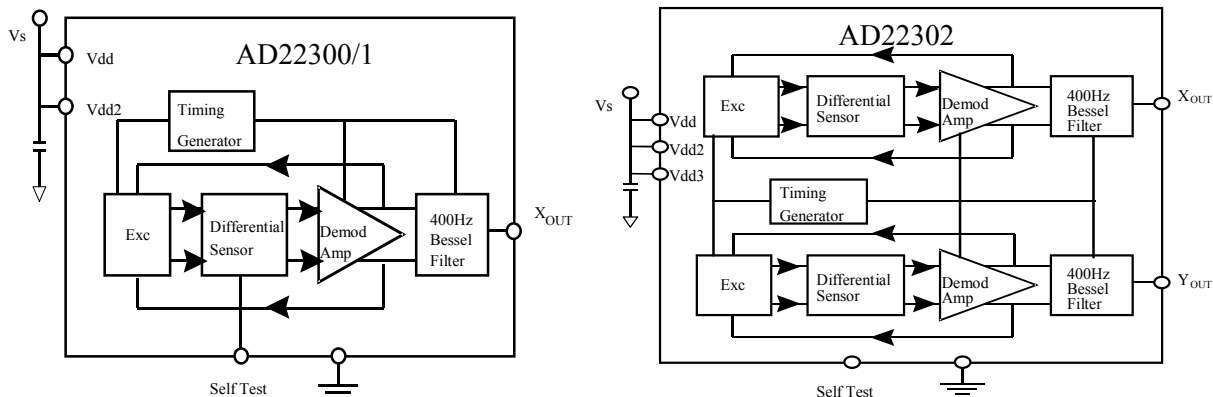

<http://www.analog.com/iMEMS>

AD22300, AD22301 - AUTOMOTIVE GRADE SPECIFICATIONS

(@ T_A = -40°C to +105°C, 3.3V DC ± 5%, Acceleration = 0g; unless otherwise noted)

	Conditions	AD22300			AD22301			units
		min	typ	max	min	typ	max	
Sensor								
Output Full Scale Range	I _{OUT} ≤ ±100μA	±37			±70			g
	I _{OUT} ≤ ±250μA	±35			±67			g
Nonlinearity			0.2	2		0.2	2	%
Package alignment error			1			1		degree
Cross-axis sensitivity		-5		5	-5		5	%
Resonant frequency			24			24		kHz
Sensitivity, Ratiometric	V _{DD} =3.3V, 100Hz, 25C	33.94	36.3	38.66	16.66	17.82	18.98	mV/g
	V _{DD} =3.3V±5%, 100Hz, temp	-6.5		6.5	-6.5		6.5	%
		10.28	11	11.72	5.05	5.4	5.75	mV/V/gee
		-6.5		6.5	-6.5		6.5	%
Offset								
Zero-g output voltage	V _{DD} =3.3V, 25C	1.51	1.65	1.79	1.56	1.65	1.74	V
	error over temp	-42.42		42.42	-27.27		27.27	mV/V
Noise								
Noise density	10Hz-400Hz, 3.3V		1.67	4.6		2.7	5.3	mg/rt Hz
Clock Noise			3.3			3.3		mV p-p
Frequency Response	2 pole Bessel							
-3dB frequency		360	400	440	360	400	440	Hz
-3dB frequency drift	25 deg C to T _{MIN} or T _{MAX}		6			6		Hz
Self Test								
Output change (cubic vs. V_{DD})	V _{DD} =3.3V	108	158	212	60	90	120	mV
Logic input high		V _{DD} -0.8			V _{DD} -0.8			V
Logic input low				0.8			0.8	V
Turn on time	to 90% of final value		1			1		ms
Input resistance	pull-down resistor to ground	30	50		30	50		kΩ
Output Amplifier								
Output voltage swing	I _{OUT} ≤ ±100μA	0.1		V _{DD} -0.1	0.1		V _{DD} -0.1	V
	I _{OUT} ≤ ±250μA	0.25		V _{DD} -0.25	0.25		V _{DD} -0.25	V
Capacitive load drive		1000			1000			pF
Pre-filter Headroom			210			420		g
CFSR			5			3		V/V
Power Supply (V_{DD})		3.135	3.3	3.465	3.135	3.3	3.465	V
Functional Voltage Range		3.135		6	3.135		6	V
Supply current		0.4	0.8	2	0.4	0.8	2	mA
Temperature Range		-40		105	-40		105	deg C

AD22302 - AUTOMOTIVE GRADE SPECIFICATIONS

(@ T_A = -40°C to +105°C, 3.3V DC ± 5%, Acceleration = 0g; unless otherwise noted)

	Conditions	AD22302			units
		min	typ	max	
Sensor					
Output Full Scale Range	I _{OUT} ≤ ±100μA I _{OUT} ≤ ±250μA	x axis: ±70 y axis: ±37 x axis: ±67 y axis: ±35			g g g g
Nonlinearity			0.2	2	%
Package alignment error			1		degree
Sensor to sensor alignment error			0.1		degree
Cross-axis sensitivity		-5		5	%
Resonant frequency			24		kHz
Sensitivity, Ratiometric	V _{dd} =3.3V, 100Hz, 25C	x: 16.66 -6.5 y: 33.94 -6.5	17.82 36.3	18.98 6.5 38.66 6.5	mV/g % mV/g %
	V _{dd} =3.3V± 5%, 100Hz, temp	x: 5.05 -6.5 y: 10.28 -6.5	5.4 11	5.75 6.5 11.72 6.5	mV/V/gee % mV/g %
Offset					
Zero-g output voltage	V _{dd} =3.3V, 25C error over temp V _{dd} =3.3V, 25C error over temp	x: 1.56 -27.27 y: 1.51 -42.42	1.65	1.74 27.27 1.79 42.42	V mV/V V mV/V
Noise					
Noise density	10Hz-400Hz, 3.3V	x: 2.7 y: 1.67 x / y: 3.3	2.7 1.67 3.3	5.3 4.6	mg/rt Hz mg/rt Hz mV p-p
Clock Noise					
Frequency Response	2 pole Bessel				
-3dB frequency		360	400	440	Hz
-3dB frequency drift	25 deg C to T _{MIN} or T _{MAX}		6		Hz
Self Test					
Output change (cubic vs. V_{dd})	V _{dd} =3.3V	x: 60 y: 108	90 158	120 212	mV mV
Logic input high			V _{dd} -0.8		V
Logic input low				0.8	V
Turn on time	to 90% of final value		1		ms
Input resistance	pull-down resistor to ground	30	50		kΩ
Output Amplifier					
Output voltage swing	I _{OUT} ≤ ±100μA I _{OUT} ≤ ±250μA	x / y : 0.1 x / y : 0.25		V _{dd} -0.1 V _{dd} -0.25	V V
Capacitive load drive			1000		pF
Pre-filter Headroom		x: 420 y: 210			g
CFSR		x: 3 y: 6			V/V
Power Supply (V_{dd})		3.135	3.3	3.465	V
Functional Voltage Range		3.135		6	V
Supply current		0.6	1.0	2	mA
Temperature Range		-40		105	deg C

ABSOLUTE MAXIMUM RATINGS*

Acceleration (Any Axis, Unpowered and Powered)	4000 g
Supply Voltage Vs	-0.3 to 7.0V
Output Short Circuit Duration (Vout, to Ground)	Indefinite
Storage Temperature	-65°C to 150°C
Soldering Temperature Range (Soldering 10 sec)	245°C
Drop Test	1.2 m
Operating Temp Range	-55°C to 125°C

* Stresses above those listed under Absolute Maximum Ratings may cause permanent damage to the device. This is a stress rating only; the functional operation of the device at these or any other conditions beyond those indicated in the operational sections of this specification is not implied. Absolute maximum ratings apply individually only, not in combination.

ORDERING GUIDE

Standard Devices	G Range	Branding
AD22300	± 35g	AD22300
AD22301	± 70g	AD22301
AD22302	± 70g X, ± 35g Y	AD22302

PIN FUNCTION DESCRIPTIONS

8-Pin LCC

Pin	AD22300/01	Description
1	NC	No internal connection
2	NC	No internal connection
3	COM	Common (connected to package lid)
4	Self-Test	Self Test Input
5	NC	No internal connection
6	Xout	Voltage Output X
7	Vdd	Power Supply
8	Vdd2	Power Supply

Pin	AD22302	Description
1	Vdd3	Power Supply
2	Yout	Voltage Output Y
3	COM	Common (connected to package lid)
4	Self-Test	Self Test Input
5	NC	No internal connection
6	Xout	Voltage Output X
7	Vdd	Power Supply
8	Vdd2	Power Supply

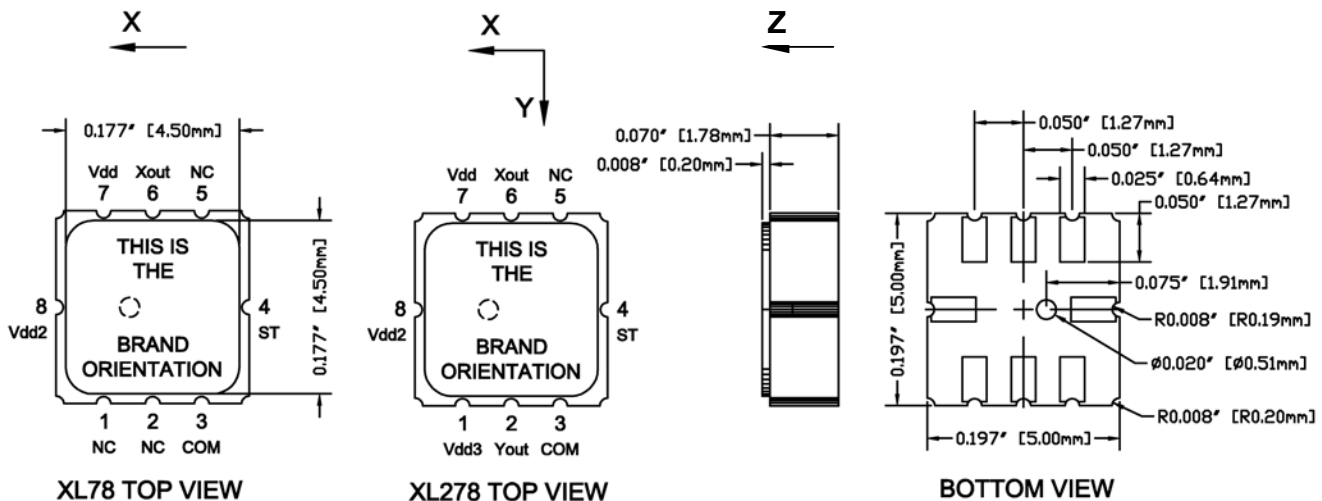

(Dimensions are nominal only. For tolerances, see the Package Outline Drawing for this part.)

Theory of Operation

The ADXL78 family provides a fully differential sensor structure and circuit path, resulting in the industry's highest resistance to EMI/RFI effects. This latest generation uses electrical feedback with zero force feedback for improved accuracy and stability. The sensor resonant frequency is significantly higher than the signal bandwidth set by the on-chip filter, avoiding the signal analysis problems caused by resonant peaks near the signal bandwidth.

Figure 1 is a simplified view of one of the differential sensor elements. Each sensor includes several differential capacitor unit cells. Each cell is composed of fixed plates attached to the substrate, and movable plates attached to the frame. Displacement of the frame changes the differential capacitance, which is measured by the on-chip circuitry.

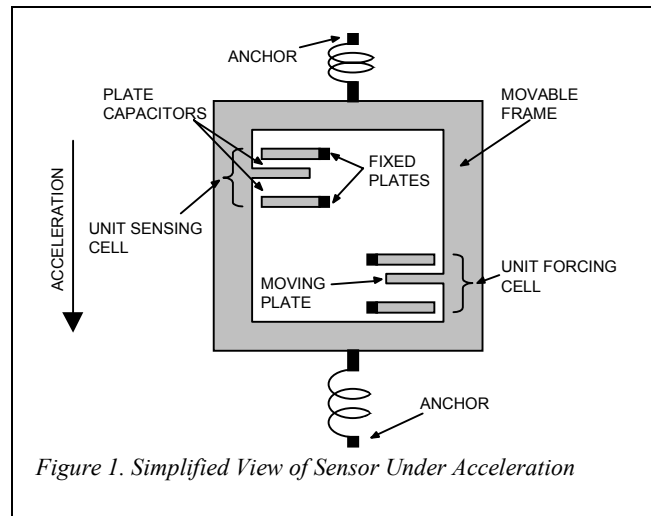

Complementary 400kHz square waves drive the fixed plates (200 kHz for the ADXL278). Electrical feedback adjusts the amplitudes of the square waves such that the AC signal on the moving plates is zero. The feedback signal is linearly proportional to the applied acceleration. This unique feedback technique ensures that there is no net electrostatic force applied to the sensor. The differential feedback control signal is also applied to the input of the filter, where it is filtered and converted to a single-ended signal.

Self-Test

The fixed fingers in the forcing cells are normally kept at the same potential as that of the movable frame. When the self-test digital input is activated, the voltage on the fixed fingers on one side of the moving plate in the forcing cells is changed. This creates an attractive electrostatic force, which causes the frame to move towards those fixed fingers. The entire signal channel is active, so the sensor displacement causes a change in V_{out} . The ADXL78 self-test function is a comprehensive method of verifying the operation of the accelerometer.

Because electrostatic force is independent of the polarity of the voltage across capacitor plates, a positive voltage is applied in half of the forcing cells, and its complement in the other half of the forcing cells. Activating self-test causes a step function force to be applied to the sensor, while the capacitive coupling term is canceled. The ADXL78 has improved self-test functionality including excellent transient response and high-speed switching capability. Arbitrary force waveforms can be applied to the sensor by modulating the self-test input, such as test signals to measure the system frequency response, or even crash signals to verify algorithms within the limits of the selftest swing.