

# HYBRID STEPPING MOTOR MOD.

☐ COLORS OF LEAD WIRES

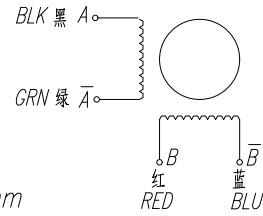

☐ DIMENSIONS unit=mm

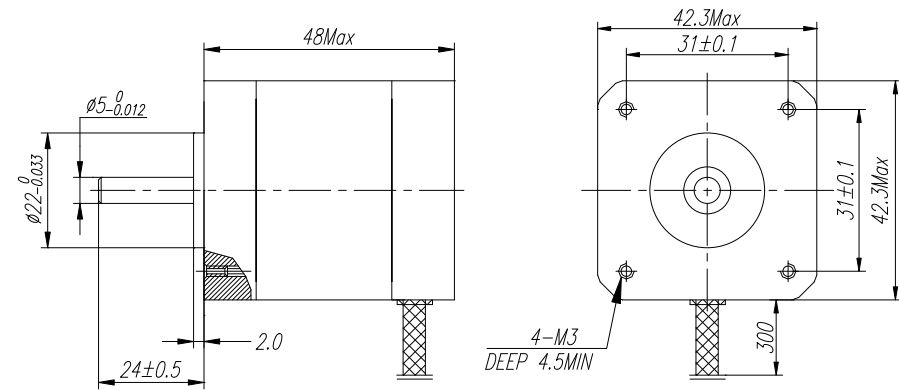

☐ SPECIFICATIONS

PHASE	相数	2	PHASE	COMMENT
STEP ANGLE	步距角	$0.9 \pm 5\%$	$^{\circ}/STEP$	
VOLTAGE	静电压	3.06	V	
CURRENT	电流	1.7	A/PHASE	
RESISTANCE	电阻	$1.8 \pm 10\%$	$\Omega/PHASE$	
INDUCTANCE	电感	$2.8 \pm 20\%$	mH/PHASE	
HOLDING TORQUE	静转矩	<b>48</b>	N.cm Min	
DETENT TORQUE	定位转矩	2.2	N.cm Max	
INSULATION CLASS	绝缘等级	B		
LEAD STYLE	引出线规格	AWG26 UL1007		

设计		20110114	审核		技术规格书	42BYGHM809
工艺			批准			www.wantmotor.com
					版本 NR	共 张 第 张

