

REFERENCE SPECIFICATIONS

-NFC 93425 (in compliance with HE 507)

PHYSICAL CHARACTERISTICS

- INSULATOR MATERIAL: THERMOPLASTIC ,UL94V0
- CONTACT MATERIAL: BRASS
- ACCESSORIES: BRASS
- SHELLS: STEEL

ELECTRICAL CHARACTERISTICS

- NOMINAL CURRENT: 40A
- CONTACT RESISTANCE: <= 7.3 mOhms
- CONTACT/CONTACT : >=1000 V
- CONTACT/GROUND : >=1200 V
- INSULATION RESISTANCE: >=5000 MOhms

ENVIRONMENTAL CHARACTERISTICS

- CLIMATIC CATEGORY: 55/125/21
- TEMPERATURE RANGE -55°C TO +125°C
- DAMP HEAT STEADY STATE 21 DAYS
- SALT SPRAY 24 HOURS

MECHANICAL CHARACTERISTICS

- RETENTION AGAINST TORQUE: - Threaded insert: 0.7 N.m maximum
- Female screw : 0.5 N.m maximum

PRESS FIT PERFORMANCES

PRESS FIT CONTACTS	
INSERTION FORCE	<= 200 N Average insertion 160N
EXTRACTION FORCE	>= 30 N

DBL5W5P93C5G40LF

Series

Shell size: **E A B C**

see sheet 2

Front accessory definition
see sheet 2

- L** : threaded insert M3
- O** : threaded insert UNC 4-40
- V** : female screw UNC 4-40

Layout of contacts (see sheet 3)

Contacts

P : Pin

Termination type

93 C Straight version

Plating

- 5** 200 matings/unmatings
- 6** 500 matings/unmatings

PCB accessories definition
see sheet 2

G : Harpoon used for PCB thickness from 1.60 mm

Power contacts

40 : Fitted with power contacts 40 Amp.

See note RoHS

NOTE RoHS INFORMATION

- The "LF" products meet european union Directives and other country regulations as described in GS-47-0004
- Termination plating spec:
 - Ni 1.27µmi+Sn 0.5 to 1.5µ(pure bright)
- Active area plating spec:
 - Ni + Gold/GxT
- Shell plating : 2 to 4µm Cu + Ni + 3 to 10µmm Sn(pure bright)
- Accessories: Sn pure bright + nickel
- Packaging spec: See GS-14-920

TABLE 1: PCB HOLE DIAMETERS

P.C.B HOLE DEFINITION	DRILL DIAMETER	SnPb holes for CONTACTS	Sn holes for CONTACTS	holes ACCESSORIES
		DRILLED HOLE	DRILLED HOLE	
(NOTE-1 AND 2)	DRILL DIAMETER	∅3.22 REF(NOTE 3)	∅3.22 REF(NOTE 3)	∅3.10±0.10
	DRILLED HOLE	∅3.19-3.25	∅3.19-3.25	
	COPPER PLATING	25µ MINI (RECOMMENDED 50µ MAXI)	25µ MINI (RECOMMENDED 50µ MAXI)	
	TIN-LEAD PLATING	15µ MAXI (RECOMMENDED 5µ MINI)		
	TIN PLATING		0.8 to 1,2µ	
	FINISH HOLE (AFTER REFLOW)	∅ 3.02-3.20	∅3.08-3.20	

NOTE-1: THESE DIMENSIONS MUST BE RESPECT TO SECURE PRESS-FIT PIN PERFORMANCES.
 NOTE-2: ACCORDING TO IEC-352-5 SPEC.
 NOTE-3: MAJOR REQUIREMENT FOR PRESS FIT PIN PERFORMANCE

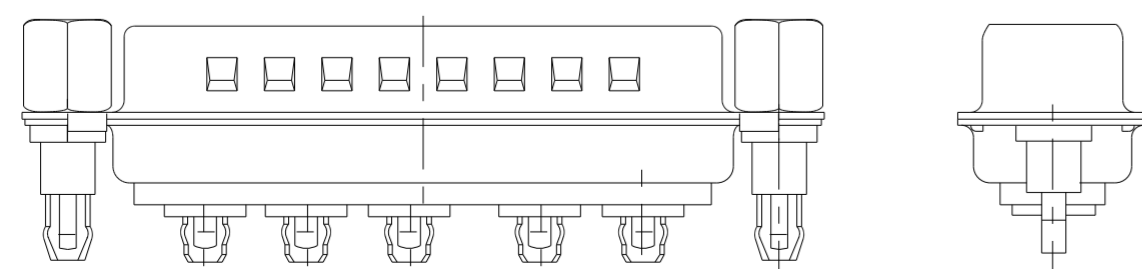

5W5 FOR EXAMPLE

spec ref	dr	1, Product Eng	2015/06/16	projection	mm	size	A2	scale	3:1
tolerance std	eng	Gregar Mathew	2020/12/04		mm	ecn no	ELX-33502-1	rel level	Released
ISO 406	chr								
ISO 1101	appr	Kuriakosa, San	2020/12/06	product family	D SUB				
surface	linear	TOLERANCES UNLESS OTHERWISE SPECIFIED		Amphenol FCI	sub male dw	cat. no.	C01-8639-2321C	rev	D
ISO 1302	angular	0.X	±0.3		full powerstraight press fit				
		0.XX	±0.1						
		0.XXX	±0.05						
		0°	±2°						

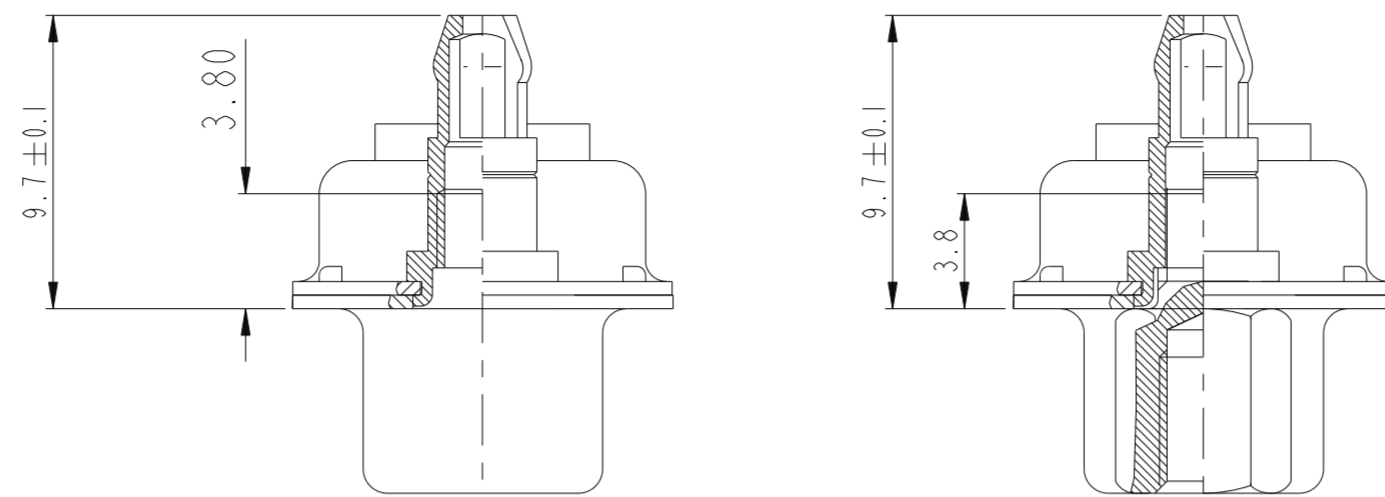

FRONT ACCESSORIES	L insert M3	V insert UNC 4.40
	O insert UNC 4.40	
PCB ACCESSORY	G Harpoon for PCB from 1.60mm	G Harpoon for PCB from 1.60mm

PART NUMBER	AMPS	MATINGS/ UNMATINGS	FRONT ACCESSORIES	PCB ACCESSORY
D*LxWxP93C5G40LF	40	200	insert M3	harpoon PCB from 1.60mm
D*OxWxP93C5G40LF	40	200	insert UNC 4.40	harpoon PCB from 1.60mm
D*VxWxP93C5G40LF	40	200	female screw UNC 4.40	harpoon PCB from 1.60mm

shell size	LAYOUTS
*	xWx
E	2V2
A	3V3
A	3W3
B	5W5
C	8W8

PART NUMBER	AMPS	MATINGS/ UNMATINGS	FRONT ACCESSORY	PCB ACCESSORIES
D*LxWxP93C6G40LF	40	500	insert M3	harpoon PCB from 1.60mm
D*OxWxP93C6G40LF	40	500	insert UNC 4.40	harpoon PCB from 1.60mm
D*VxWxP93C6G40LF	40	500	female screw UNC 4.40	harpoon PCB from 1.60mm

spec ref	dr	1, Product Eng	2015/06/16	projection	mm	size	A2	scale	3:1	
tolerance std	eng	Gregar Mathew	2020/12/04		mm	ecn no	ELX-33502-1	rel level	Released	
ISO 406	chr	-								
ISO 1101	appr	Kuriakosa, San	2020/12/06							product family
surface	linear	0.X	±0.3		title sub male dw full powerstraight press fit	dwg no C01-8639-2321C	rev D	cat. no.	Product - Customer Drw	sheet 2 of 4
ISO 1302		0.XX	±0.1							
	angular	0°	±2°							

2V2

LAYOUT AND CONNECTOR DIMENSIONS

For PCB hole diameters see table I sheet 1

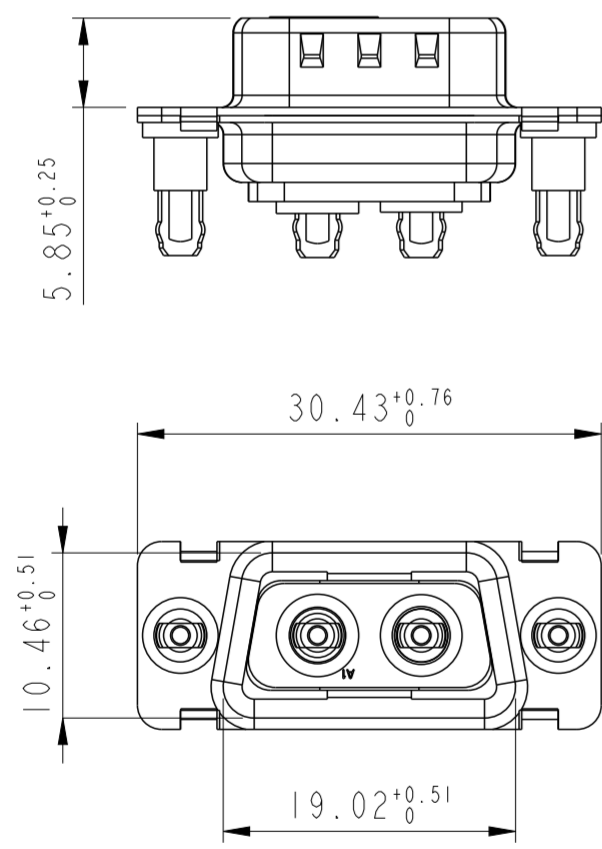
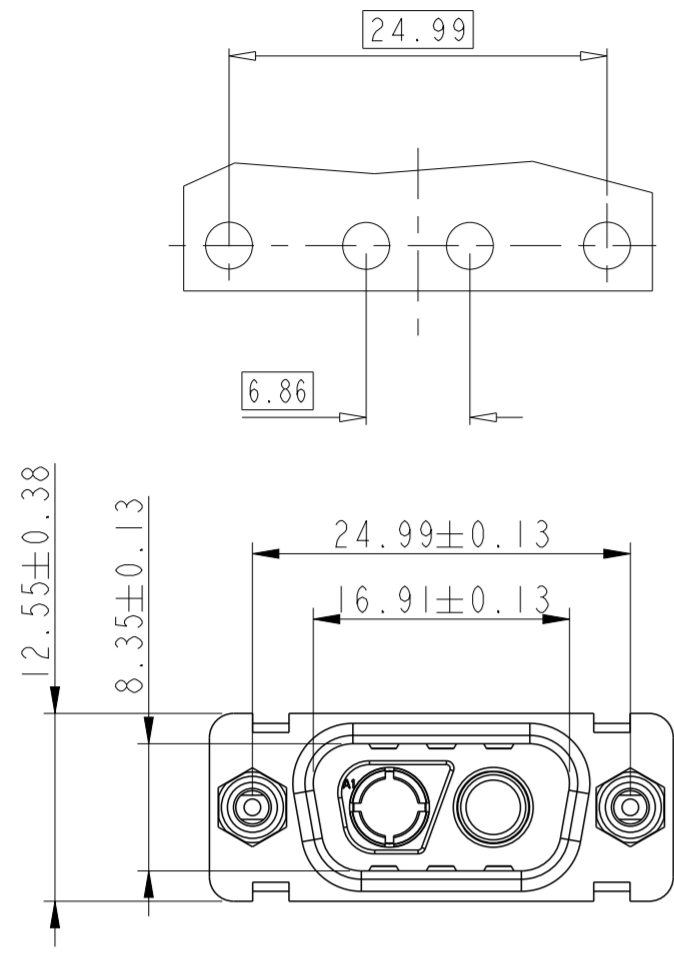

3V3

LAYOUT AND CONNECTOR DIMENSIONS

For PCB hole diameters see table I sheet 1

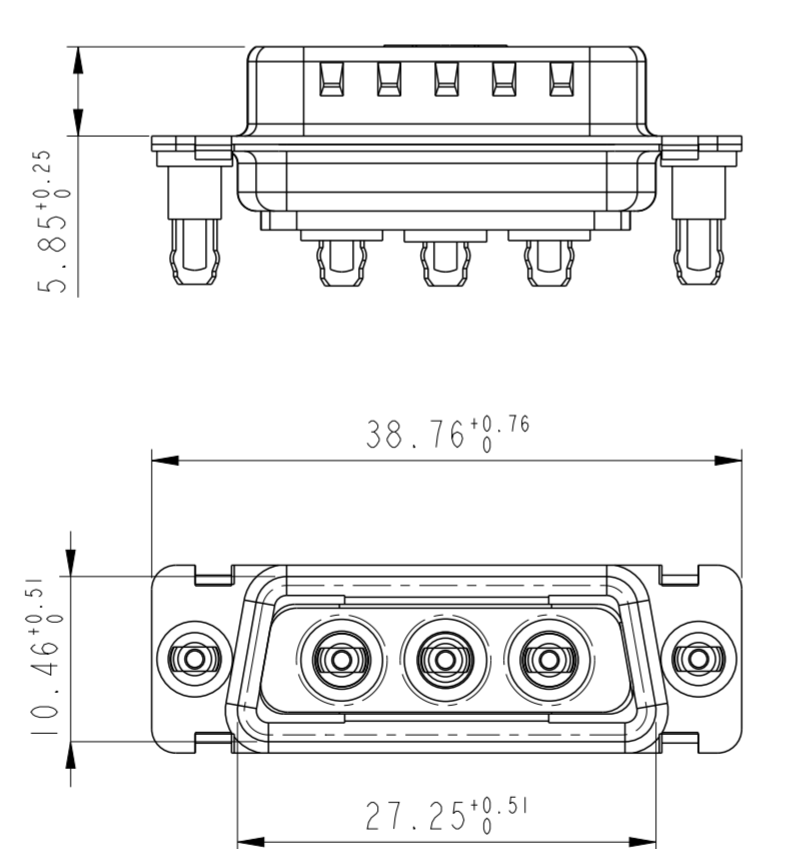
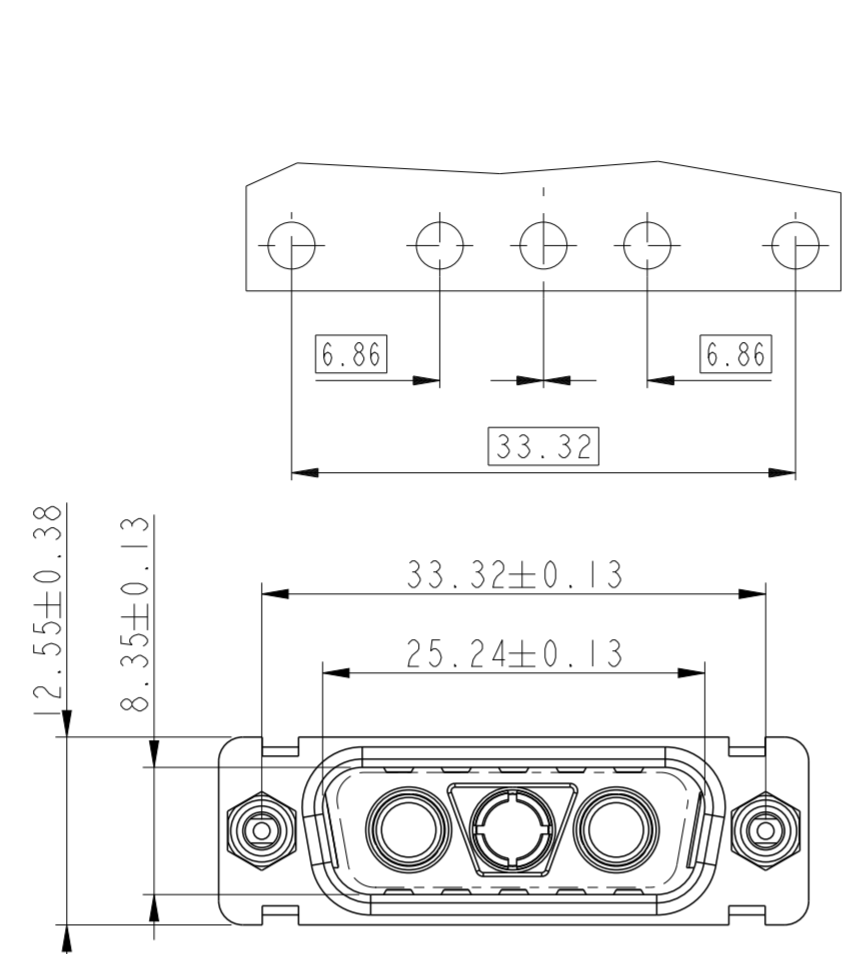

3W3

LAYOUT AND CONNECTOR DIMENSIONS

For PCB hole diameters see table I sheet 1

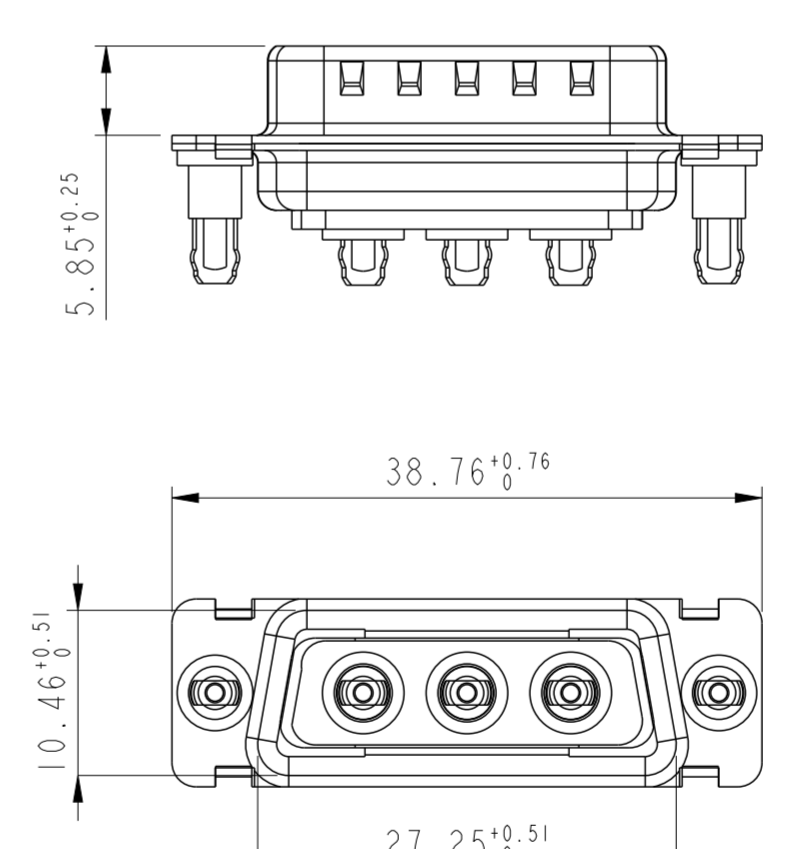
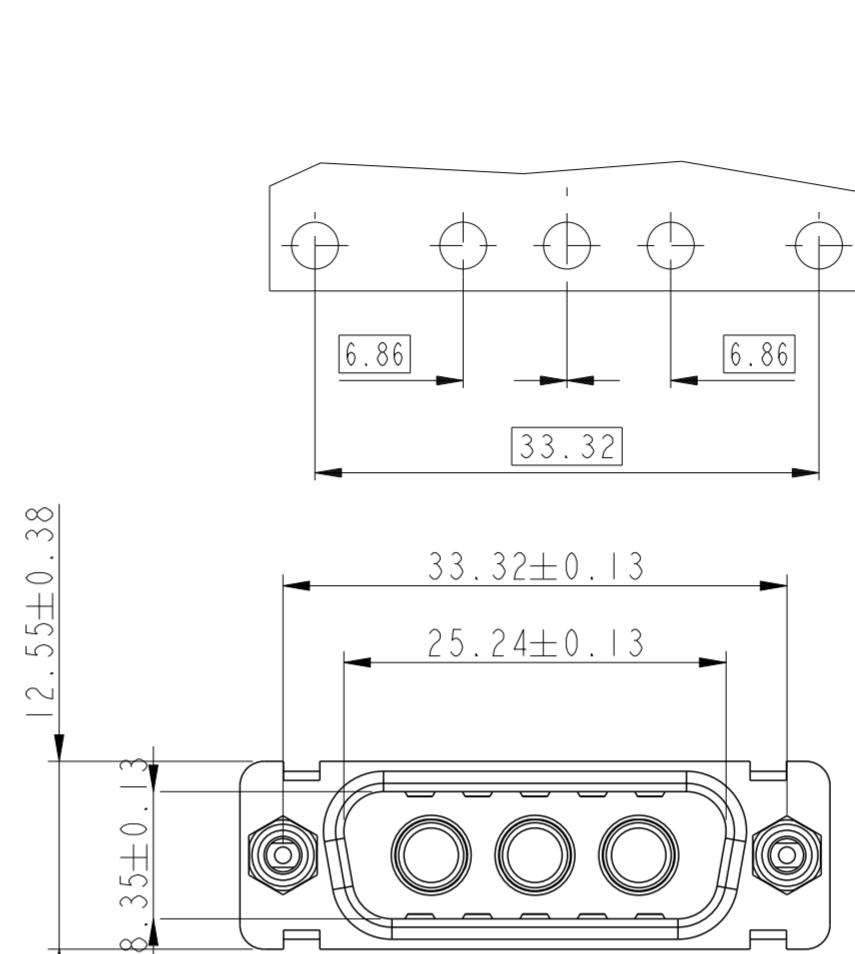

SIDE VIEW FOR LAYOUTS: E A B C

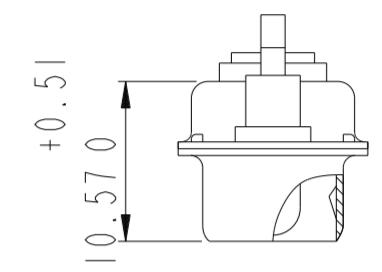

DETAIL OF PRESS FIT

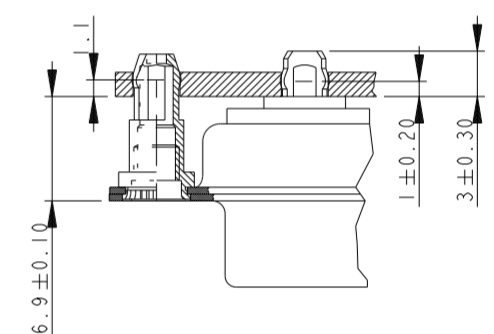

Amphenol FCI

© 2016 AFCI

spec ref	dr	1, Product Eng	2015/06/16	projection	mm	size	A2	scale	2:1
tolerance std	eng	Gregar Mathew	2020/12/04			ecn no	ELX-433502-1	Product - Customer Drw sheet 3 of 4	rev D
ISO 406	chr	-	rel level			Released			
ISO 1101	appr	Kuriakosa, San	2020/12/06						
surface	linear	0.X	±0.3	Amphenol FCI sub male dw full powerstraight press fit		dwg no	C01-8639-2321C		
ISO 1302	angular	0°	±2°	cat. no. -					

PDS: Rev :D

STATUS:Released

Printed: Dec 18, 2020

5W5

LAYOUT AND CONNECTOR DIMENSIONS

For PCB hole diameters see table 1 sheet 1

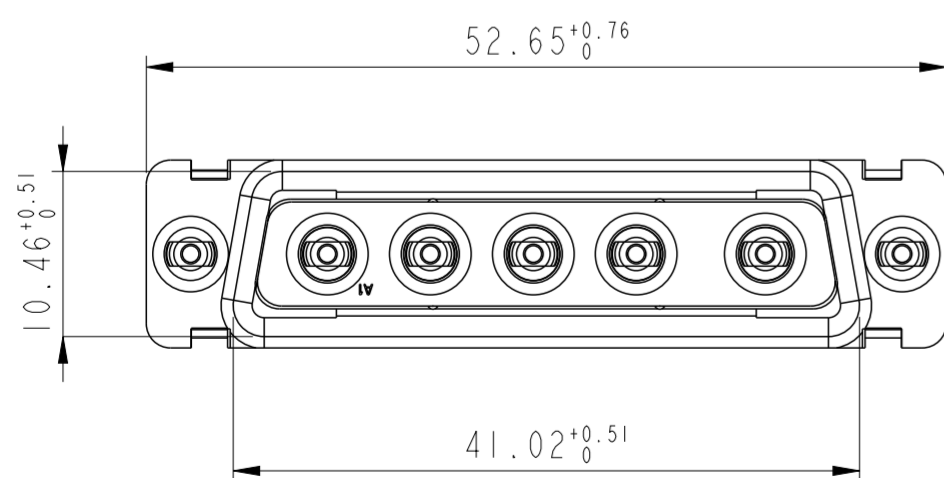
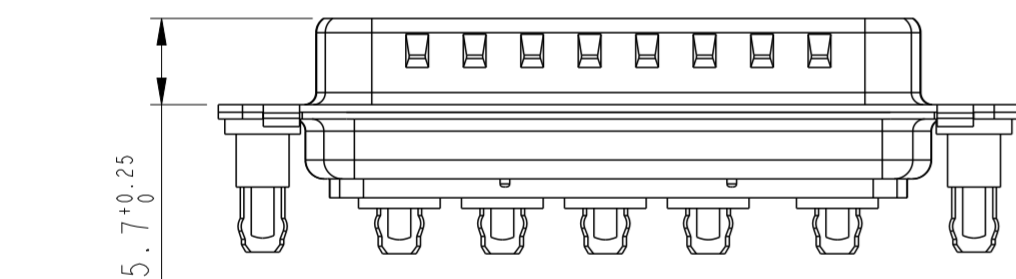
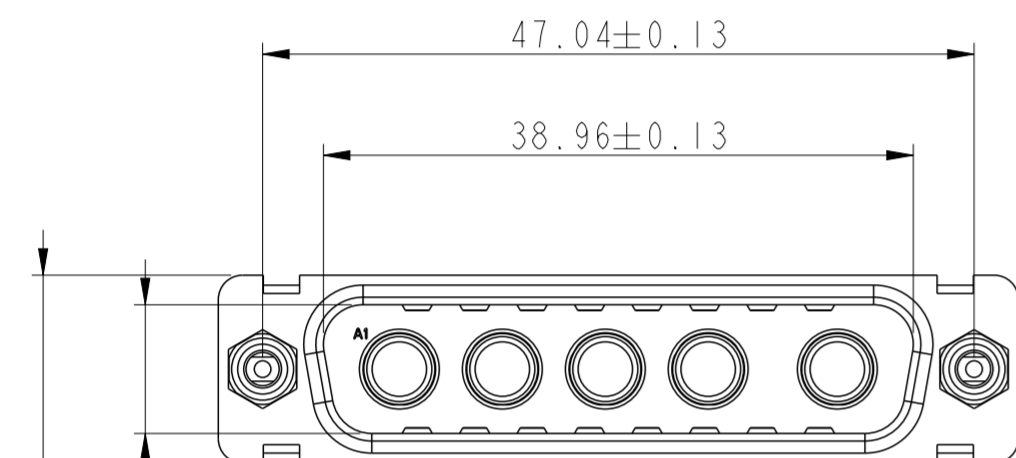
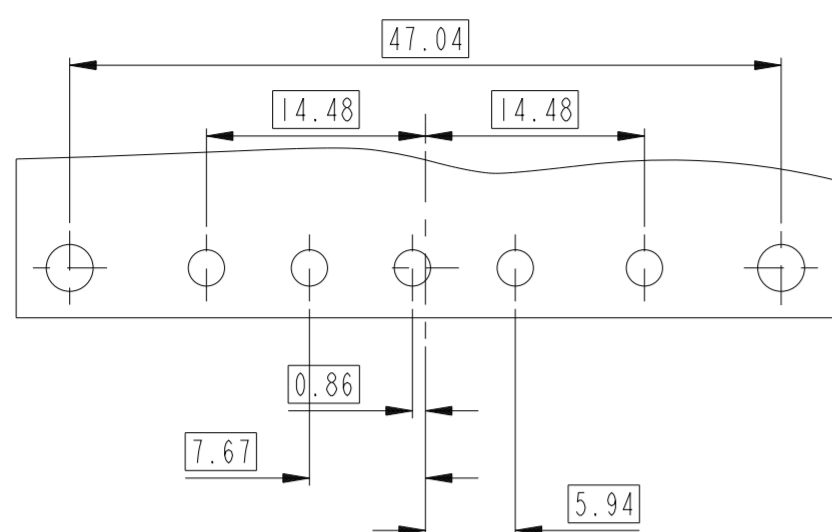

8W8

LAYOUT AND CONNECTOR DIMENSIONS

For PCB hole diameters see table 1 sheet 1

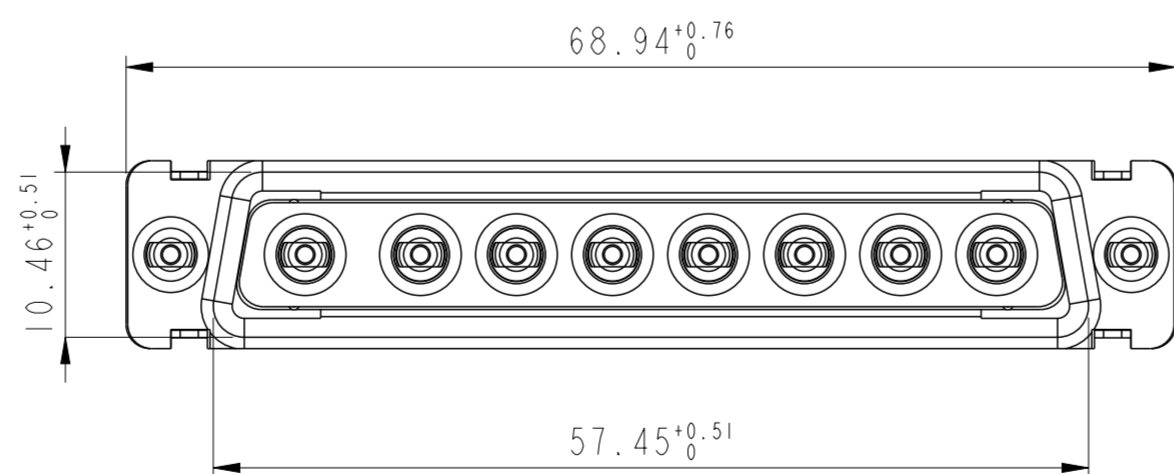
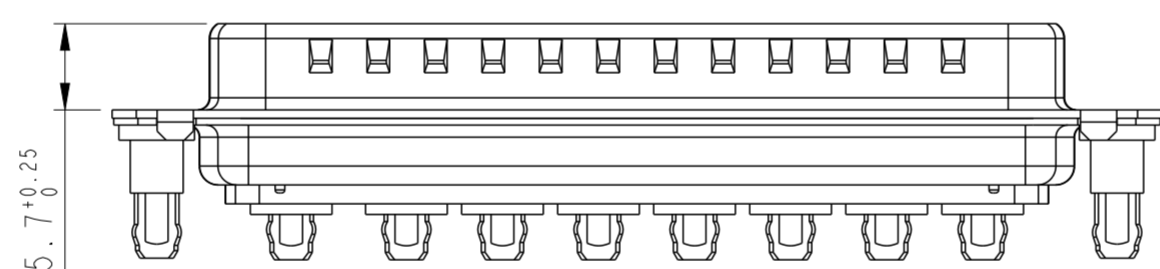
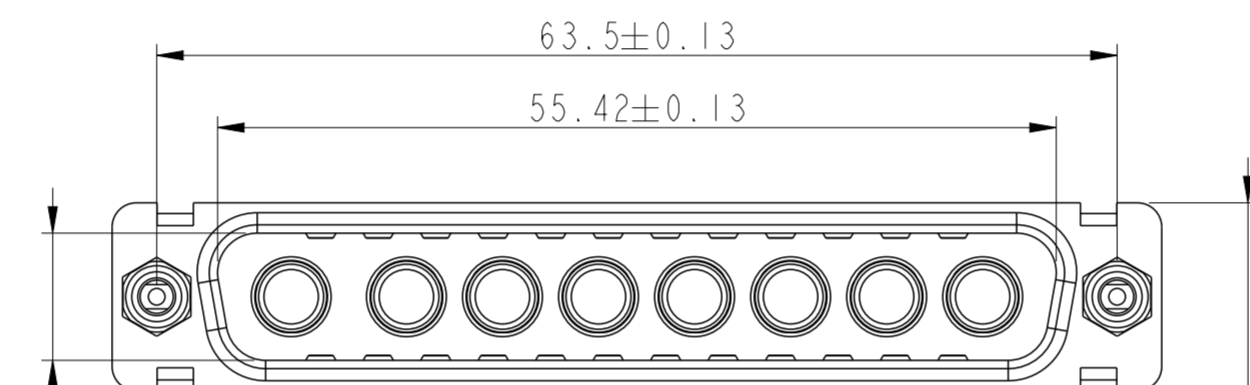
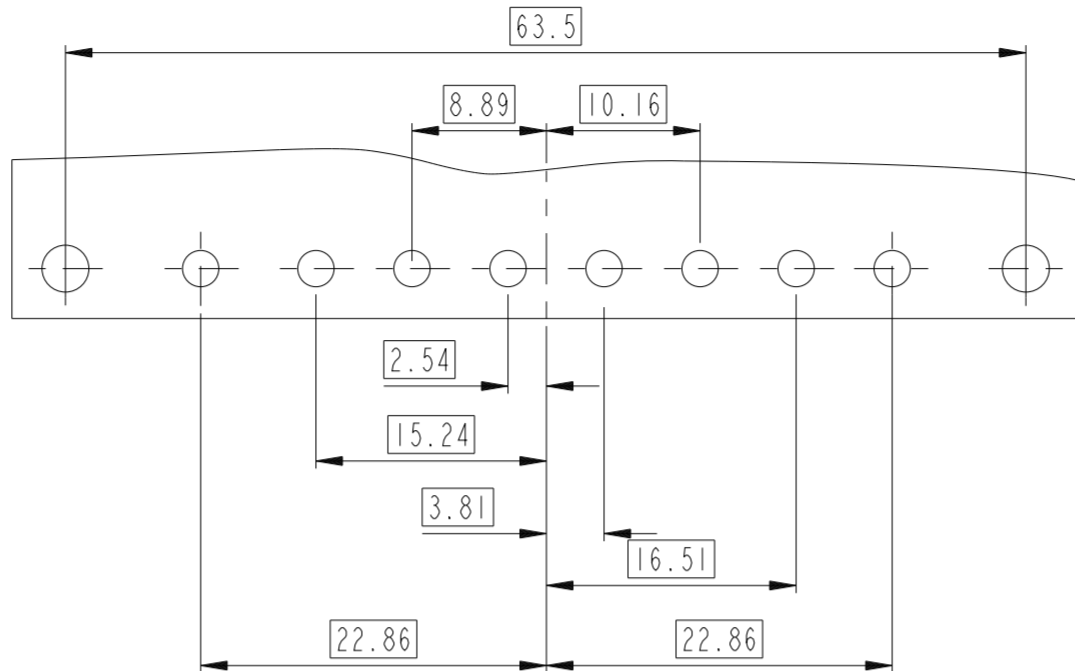

Amphenol FCI

© 2016 AFCI

spec ref	dr	1, Product Eng	2015/06/16	projection	mm	size	A2	scale	2:1
tolerance std	eng	Gregar Mathew	2020/12/04		mm	ecn no	ELX-33502-1	rel level	Released
ISO 406	chr	-	product family						
ISO 1101	appr	Kuriakosa, San	2020/12/06	Amphenol FCI		title sub male dw		dwg no C01-8639-2321C	rev D
surface	linear	0.X	±0.3	full powerstraight press fit		cat. no. -		Product - Customer Drw	
ISO 1302	angular	0°	±2°	sheet 4 of 4		PDS: Rev :D		STATUS:Released	

PDS: Rev :D

STATUS:Released

Printed: Dec 18, 2020