



Smart Energy Solution Guide



It's All About Energy Management

The market for energy, water and gas metering systems is rapidly changing, driven by new environmental and conservation concerns and regulations. Traditional standalone meters are now being replaced by complex networked systems that utilize a variety of communication methods. To meet the needs of this evolving smart grid, you need solutions that can provide:

- Leading-edge connectivity
- Best-in-class metrology
- Integration and flexibility
- Advanced security

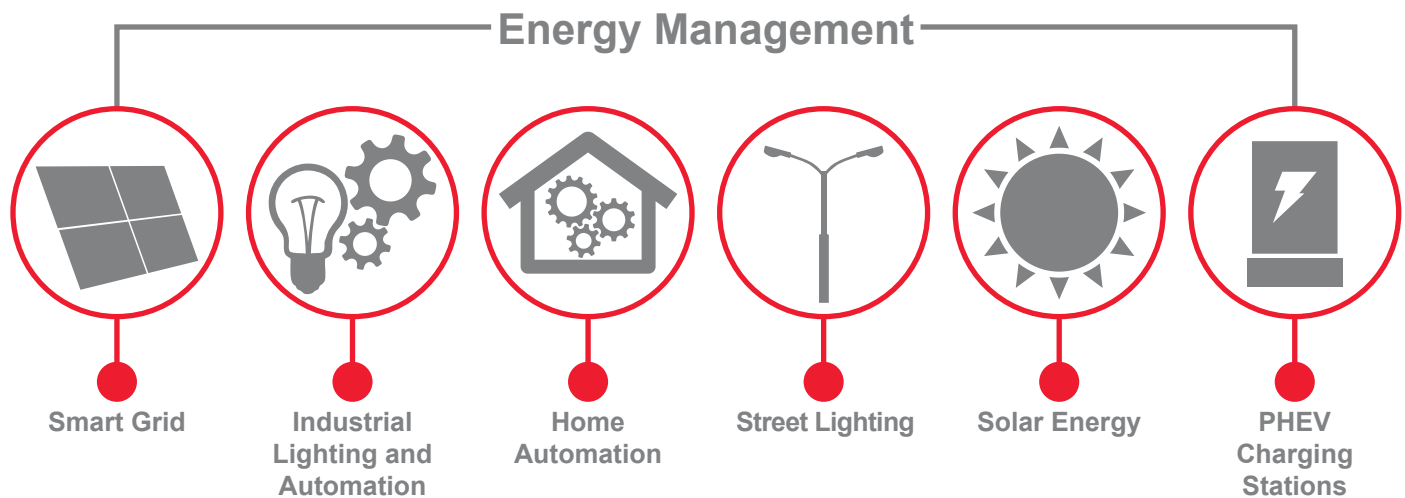

Not Just a Chip, But a Platform

Microchip addresses the needs of the smart energy market with application-specific, as well as standard microcontroller, micro-processor, security, memory, wireless and power-line connectivity devices. The application-specific portfolio is defined from the ground up to offer designers best-in-class feature sets and performance in various classes of equipment used in the smart grid. Many of the devices in the Smart Energy Platform are part of the Arm®-based microcontrollers.

HAN Gateway

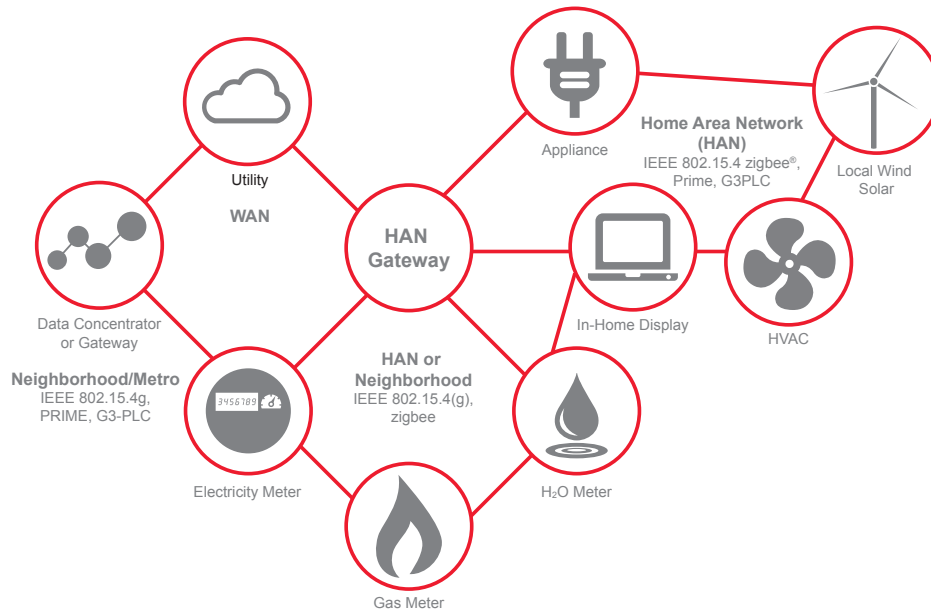

Smart Energy Products by Equipment Type

	Home Area Network Equipment	Energy Gateway	Data Concentrator	Electricity Meter	Gas & Water Meter
M90E32/36	✓	–	✓	✓	–
M90E26	–	–	–	✓	–
SENSE	–	–	✓	✓	–
MCP391x	–	–	✓	✓	–
PL360	✓	✓	✓	✓	–
PL230	✓	✓	✓	✓	–
PL250	✓	✓	✓	✓	–
86RF212B	✓	✓	–	✓	✓
86RF233	✓	✓	–	✓	✓
86RF215	–	✓	✓	✓	–
86RF215M	–	✓	✓	✓	✓
SAM4C	✓	✓	✓	✓	✓
SAM4CM	✓	–	✓	✓	–
SAM4CP	✓	✓	✓	✓	–
SAMD	–	–	–	–	✓
SAM4L	✓	–	–	✓	✓
SAMA5	–	✓	✓	–	–

Today's smart meter architect demands various levels of integration depending on system architecture partitioning, project time-lines, and the level of flexibility needed to address various utility and geographical requirements. The Microchip platform provides a unique multi-level architecture built around the same multi-core architecture as outlined below. Various devices integrate the building blocks of the smart meter, namely, metrology sensing (ADC), metrology DSP, application, communication and security processing, as well as connectivity to home area and neighborhood area networks.

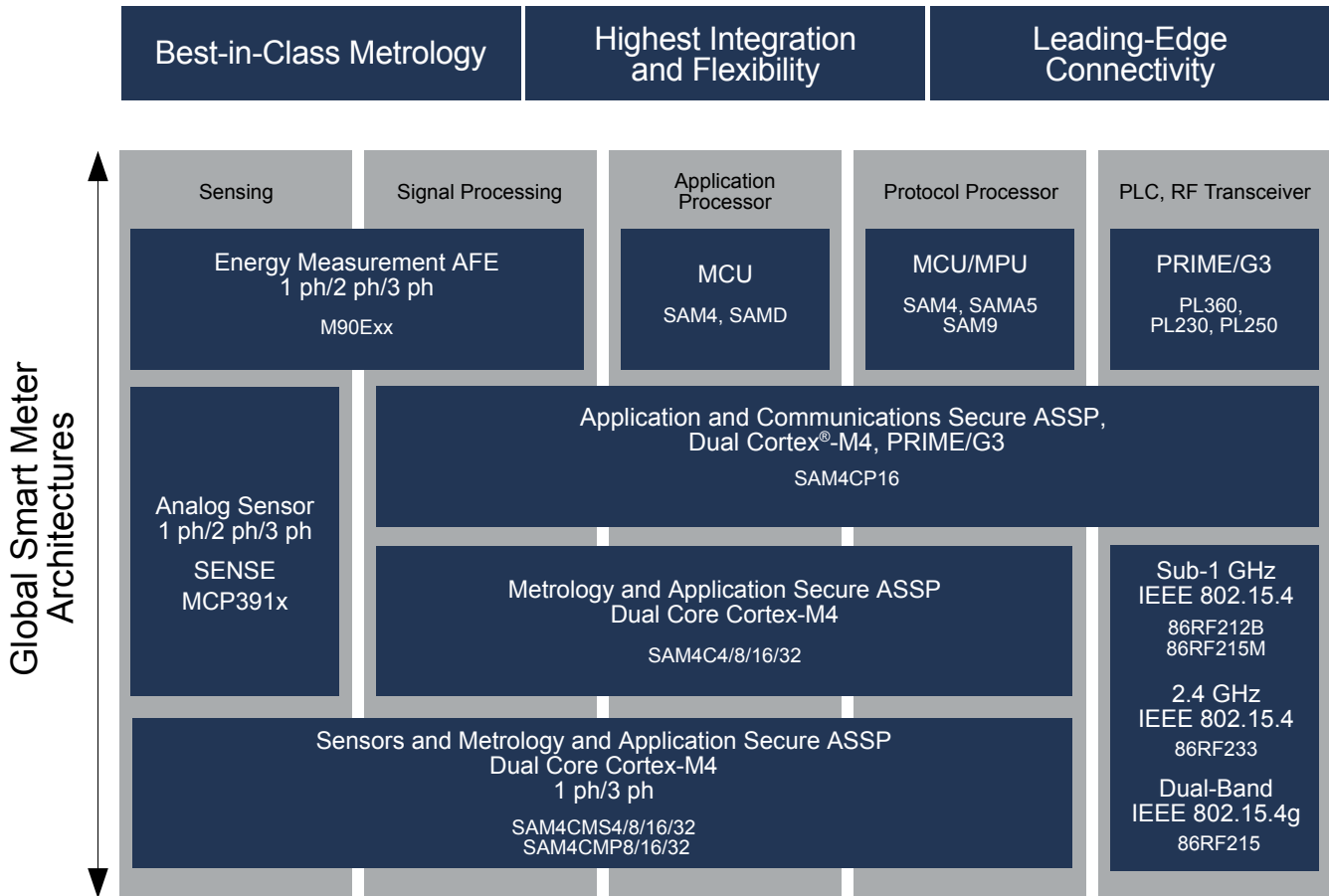

Value Proposition

The Broadest Portfolio Targeting the Metering Market

- Leading-edge connectivity
 - Low-power IEEE 802.15.4 wireless devices
 - Field-proven, low-power PLC (PRIME/G3)
- Integration and flexibility
 - Flexible (SW or HW) metrology
 - Multi-standard wireless and PLC solutions
 - Advanced cryptography
- Best-in-class Metrology
 - Stand-alone sensing Analog Front End (AFE) and SoC with integrated AFE offering
 - Dynamic range of up to 10000:1
- Broad Arm-based portfolio
 - Large array of SAMD, SAM4 and SAMA5 solutions
 - Best-in-class tools from Microchip, IAR, Keil

Newest Smart Energy Platform Core: SAM4C

At the core of Microchip's smart energy platform is the SAM4C series of products. The SAM4C4/8/16/32 system-on-chip solutions for smart energy applications are built around two high-performance 32-bit Arm Cortex®-M4 RISC processors. These devices operate at a maximum speed of 120 MHz and feature up to 2 MB of embedded Flash, 304 KB of SRAM and on-chip cache for each core.

The dual Arm Cortex-M4 architecture allows for integration of application layer, communications layers and metrology functions in a single device. It has options for integrated software metrology or external hardware metrology AFE as well as integrated or external Power-Line Carrier (PLC) physical layer solution. It's a modular approach that is sure to meet various design needs.

SAM4C Platform

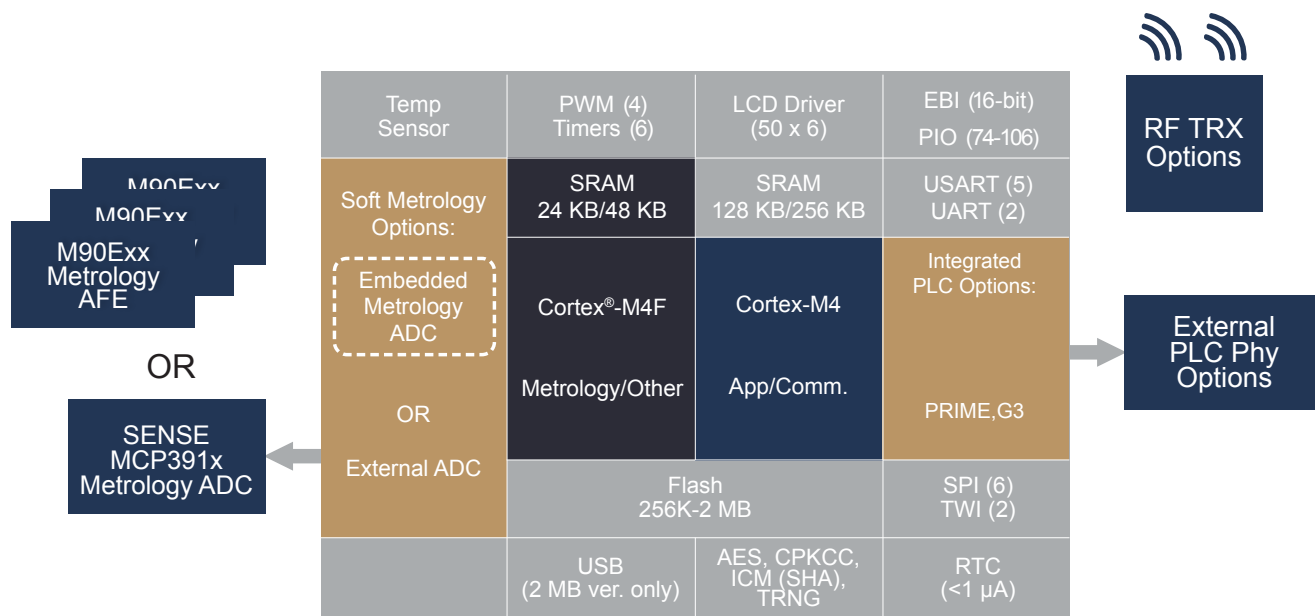

SAM4C Block Diagram

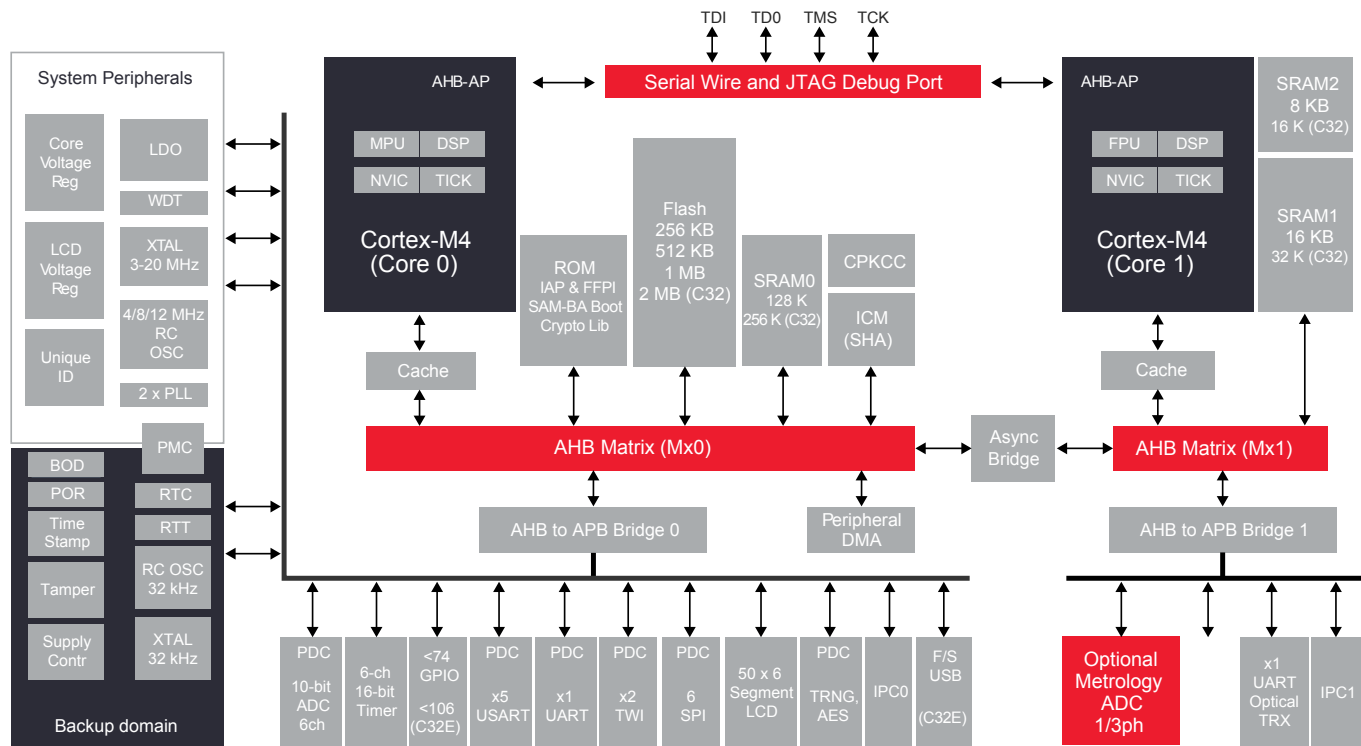

C32 devices have 2 MB Flash, full speed USB, more GPIO, more RAM

SAM4C Metering SoC Feature Comparison

	SAM4C4	SAM4C8	SAM4C16	SAM4C32C	SAM4C32E	SAM4CMS4	SAM4CMP8/ SAM4CMS8	SAM4CMP16/ SAM4CMS16	SAM4CMP32/ SAM4CMS32
Flash	256 KB	512 KB	1 MB	2 MB		256 KB	512 KB	1 MB	2 MB
SRAM	128 + 16 + 8 KB			256 + 32 + 16 KB		128 + 16 + 8 KB		256 + 32 + 16 KB	
Package	100-pin LQFP				144-pin LQFP		100-pin LQFP		
GPIO	74				106		52/57		
PWM	4				106		3		
UART+USART	7				106		5/6		
SPI	2 Controllers - 8 CS, + 5 USARTs in SPI Mode					1 Controller - 4 CS + 3/4 USARTs in SPI Mode			
ADC	10-bit, 6 x Externals + 2 x Internals					10-bit, 4 x Externals + 2 x Internals			
Metrology AFE	-				7 x Channels/4 x Channels				
Segment LCD	50 x 6				33 x 6/38 x 6				
USB FS	-				Host/Device		-		
Timer	6 Channels								
TWI	2								

SAM4Cx Software Metrology

Flexibility to Support Various Country-Specific Requirements

Microchip's software metrology library provides unprecedented level of performance, scalability and flexibility which supports the integration of proprietary advanced metrology and signal processing algorithms. Microchip's standard library enables residential, commercial and industrial meter design up to class 0.2 accuracy, dynamic range of 3000:1, supports shunt, current transformer and Rogowski coil current sensing and is compliant with IEC 62052-11, 62053-22/23, ANSI C12.1, C12.20 and MID.

The SENSE-301, SENSE-201 and SENSE-101 are AFE devices targeting work in conjunction with the SAM4Cx products. They feature up to seven channels of high-precision delta-sigma Analog-to-Digital Converters (ADCs) with a 16 ksps sample rate and a highly accurate, integrated voltage reference with 10 ppm/°C temperature stability. They also include programmable current signal amplification, a temperature sensor and a Serial Peripheral Interface (SPI).

SENSE Features

- 0.1% accuracy over 3000:1 range
- Shunt, CT and Rogowski coil support
- 50 ppm/°C reference, 10 ppm/°C (H version)
- Works with Microchip metrology library
- Ultra-low power: < 2.5 mW/channel @ 3.3V
- 8 MHz SPI compatible mode 1 (8-bit) for ADC data and AFE controls.
- SENSE-301(H)
 - 32-pin TQFP package
 - Seven synchronous delta-sigma ADCs, <16 Ksps
 - 3-V, 4-I channels with 8x PGA
- SENSE-201(H)
 - 32-pin TQFP package
 - Four synchronous delta-sigma ADCs, <16 Ksps
 - 2-V, 2-I channels with 8x PGA
- SENSE-101(H)
 - 20-pin SOIC package
 - Three synchronous delta-sigma ADCs, <16 Ksps
 - 1-V, 2-I channels with 8x PGA

The MCP391x products are a family of high-performance, flexible AFE devices that can be used alongside your MCU of choice. They feature up to 8 channels of synchronous sampling 16-24-bit delta-sigma ADCs with programmable data rate, integrated voltage reference, as well as phase delay compensation and programmable gain amplifiers on each channel. They also include security features, such as 16-bit CRC and register map lock, with a high-speed 20 MHz SPI.

MCP391x Features

- Enables 0.1% error over 10000:1 range
- Up to 94.5 dB SINAD, -107 dBc THD, 112 dBFS SFDR
- Programmable data rate up to 125 Ksps
- Oversampling ratio up to 4096
- PGA on each channel up to 32V/V
- Low drift voltage reference: 9 ppm/°C
- High-speed 20 MHz SPI
- Security features:
 - 16-bit CRC
 - Register map lock
- MCP3918/10/19
 - 1, 2, or 3-ch AFE
 - Optimal 2-wire interface mode for poly-phase shunt meters
 - 20/28-pin QFN and SSOP packages

SAM4CM Linear Curve

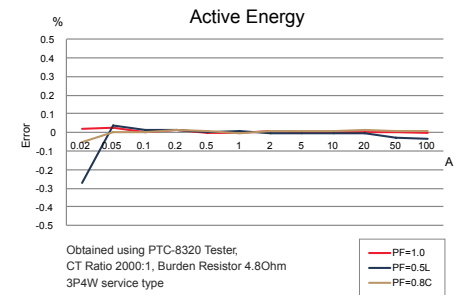

SENSE Block Diagram

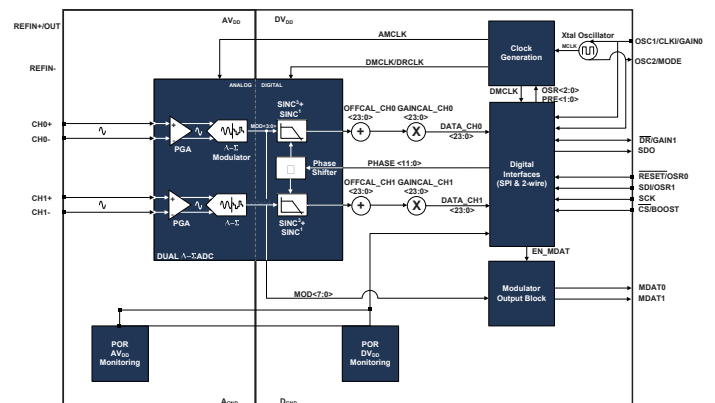
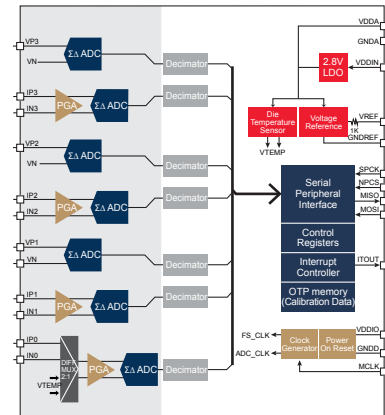

- MCP3912/13/14
 - 4-6, or 8-ch AFE
 - 20 MHz SPI
 - 28-pin QFN and SSOP packages, 40-pin UQFN package

Hardware Metrology AFE

Out of the Box Solution for Basic Metering

- Ideal for basic meter designs
 - Up to class 0.2 accuracy
 - Exceeds IEC, ANSI standards
 - Best-in-class temperature drift
- Best-in-class dynamic range (up to 6000:1)
 - Improves performance
 - Reduces OEM's cost of manufacturing
- Great fit with SAM4L
 - picoPower® technology
 - Active mode @ 90 μ A/MHz
 - Full RAM retention @1.5 μ A
 - SleepWalking
 - 4 x 40 segment LCD controller
 - Hardware crypto block

M90E36A Linearity

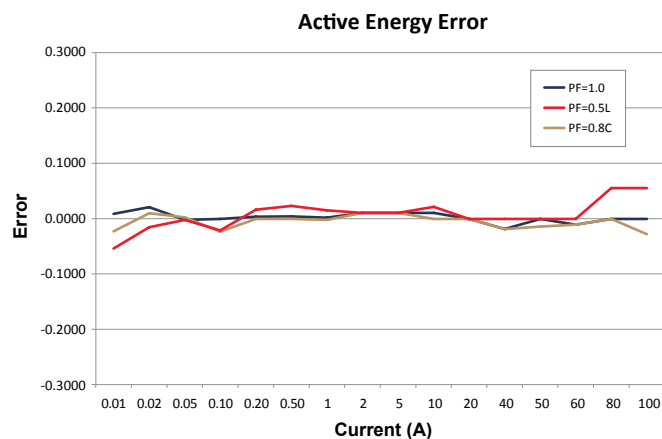

Microchip Metrology Solutions

	Service Type	Dynamic Range	Active Energy Accuracy	Reactive Energy Accuracy	Key Features
SAMC4/8/16/32	-	-	-	-	Security SoC
SAM4CMS4/8/16/32	1 phase	3000:1	0.1%	0.2%	High-End Metrology SoC
SAM4CMP8/16/32	3 phase	3000:1	0.1%	0.2%	
SENSE101	1 phase	3000:1	1%	1%	Software Metrology ADC
SENSE201	2 phase	3000:1	0.2%	0.2%	
SENSE301	3 phase	3000:1	0.2%	0.2%	
MCP3910/18/19	1 phase 2 phase (shunt) 3 phase (shunt)	10000:1	0.1%	0.2%	Software Metrology ADC
MCP3912	2 phase	10000:1	0.1%	0.2%	AFE, active, reactive energy, instantaneous and anti-tamper
MCP3913/14	3 phase	10000:1	0.1%	0.2%	
M90E26	1 phase	5000:1	0.1%	0.2%	
M90E32AS	3 phase	6000:1	0.1%	0.2%	AFE, active, reactive energy, instantaneous, fundamental and harmonics measurement, piece-wise compensation, event detection
M90E36A	3 phase	6000:1	0.1%	0.2%	AFE, active, reactive energy, instantaneous, fundamental and harmonics measurement, Discrete Fourier Transform (DFT) Function, raw data capture

PLC Connectivity Products

Microchip offers PLC solutions designed specifically for narrowband communications using the low-voltage electric grid. Drawing on our deep expertise in PLC modem technology and extensive collaboration with utilities and metering OEMs, we've created solutions offering an unprecedented level of integration and performance. Our solutions support various standards such as PowerLine Intelligent Metering Evolution (PRIME) and G3-PLC. Thanks to the communications software provided by our solution, the management of PLC networks turns into a transparent process. You can focus on top-level applications and access the Microchip PLC software stack via user-friendly application programming interfaces (APIs).

- Best-in-class sensitivity and high-temperature stability
- Improved AFE providing outstanding efficiency
- Price-competitive, high-performance solutions
- Free software stacks for PLC

Flexible Architecture

Microchip PLC solutions are offered in single-chip (SoC) and two-chip (PHY modem + MCU) configurations, respectively. Both configurations are available for PRIME and G3 solutions. Microchip PRIME devices comply with state-of-the-art PRIME 1.3 and PRIME 1.4 specifications and include enhanced PRIME features such as additional robust modes and frequency band extension up to 500 kHz. Microchip's G3 devices support all modulation schemes and modes (coherent, differential) defined in the G3-PLC specification.

Microchip PLC Solutions with a Flexible Architecture

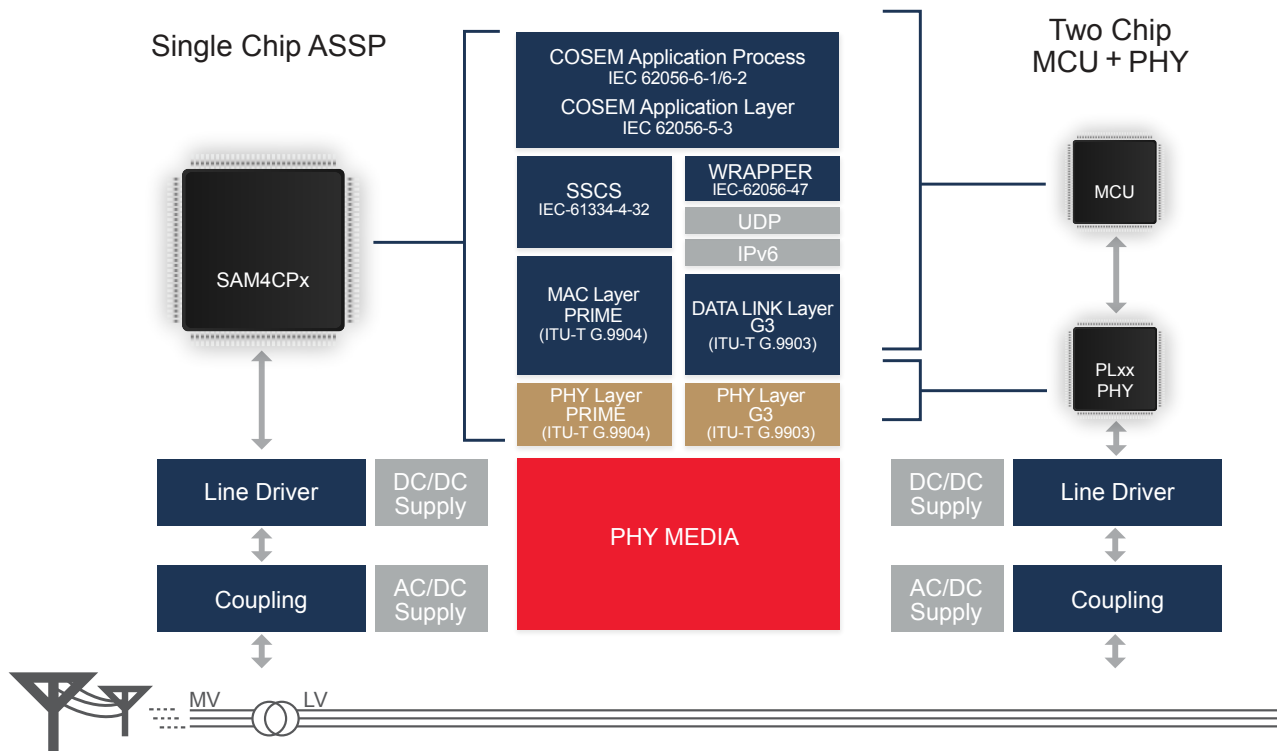

A built in class-D amplifier architecture is up to 30% more efficient than competing solutions with only a handful of external discrete components, reducing power waste due to heat dissipation and increasing long-term reliability due to better thermal behavior.

An extensive array of system I/O, LCD, memory, RTC, DMA and cryptographic resources available in the SAM4CP series allow integration of application, communication and metrology software (using external Microchip metrology devices) to achieve highly reliable, flexible and cost effective smart meter designs.

Microchip provides PRIME and G3 software stacks that turn the management of PLC networks into a transparent process. You can focus on top-level applications and access the Microchip PLC software stacks via well defined Application Programming Interfaces (APIs).

PLC Product Features

	Standard	Frequency Band	Core	CPU Clock	Flash	SRAM	Package
PL360	Multi-protocol	CEN/ARIB/FCC 3–500 kHz	Cortex®-M7	216 MHz	–	192 kB for data and code	48-pin TQFP/QFN
PL230A	PRIME	CEN/ARIB/FCC 3–500 kHz	–	–	–	–	80-pin LQFP
PL250A	G3	CEN/ARIB/FCC 3–500 kHz	–	–	–	–	80-pin LQFP
SAM4CP16B	PRIME	CEN/ARIB/FCC 3–500 kHz	Dual Cortex-M4	120 MHz @core	1 MB	128 +16 + 8 KB	176-pin LQFP
SAM4CP16C	G3	CEN/ARIB/FCC 3–500 kHz	Dual Cortex-M4	120 MHz @core	1 MB	128 +16 + 8 KB	176-pin LQFP

PL360 Block Diagram

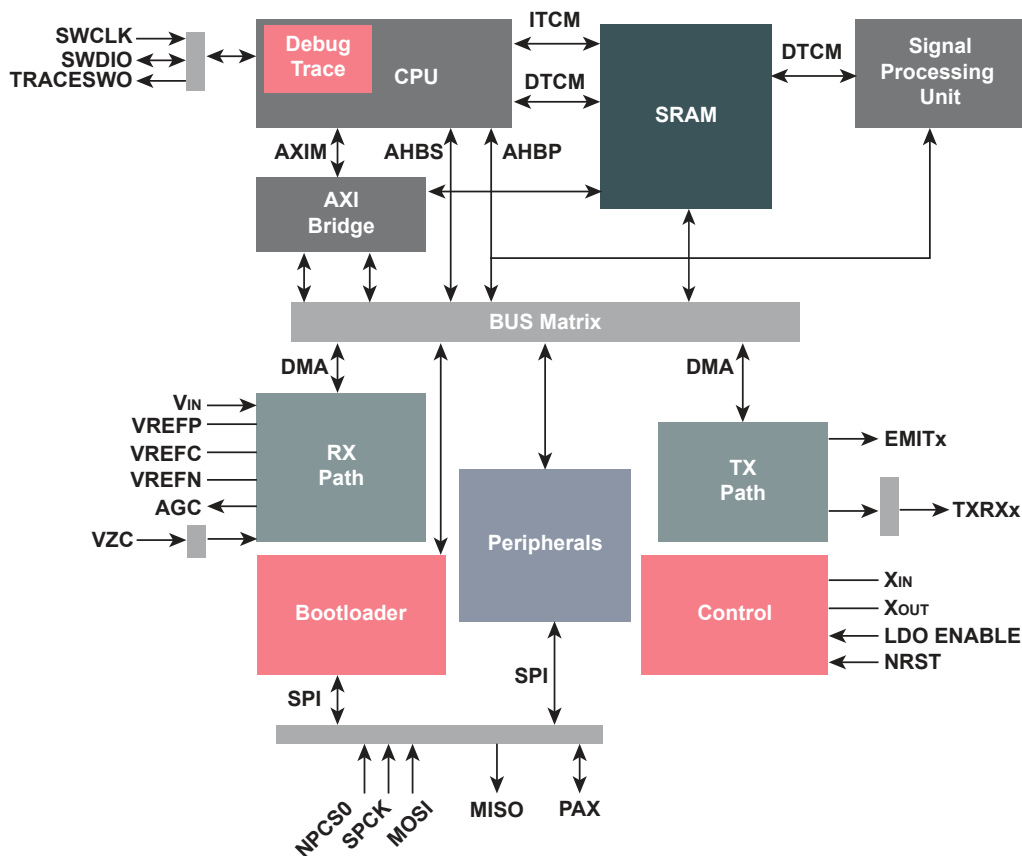

PLC Module Solutions

Microchip PLC modules are designed to support applications that require a Power Line Communication interface, combining a versatile microcontroller with Microchip analog front ends for Power Line Communication.

The microcontroller is an Arm Cortex-M4 (120 MHz, 512 kB Flash, 128 kB RAM) able to implement both PLC stack and control application.

Microchip PLC front ends support PRIME PLC and G3 PLC. They operate in the band below 500 kHz and can provide baud rates from 4.5 kbps to 166 kbps. Microchip OFDM-based PLC technology is designed to provide high data throughput and enhanced robustness in order to establish successful communications across noisy electric lines.

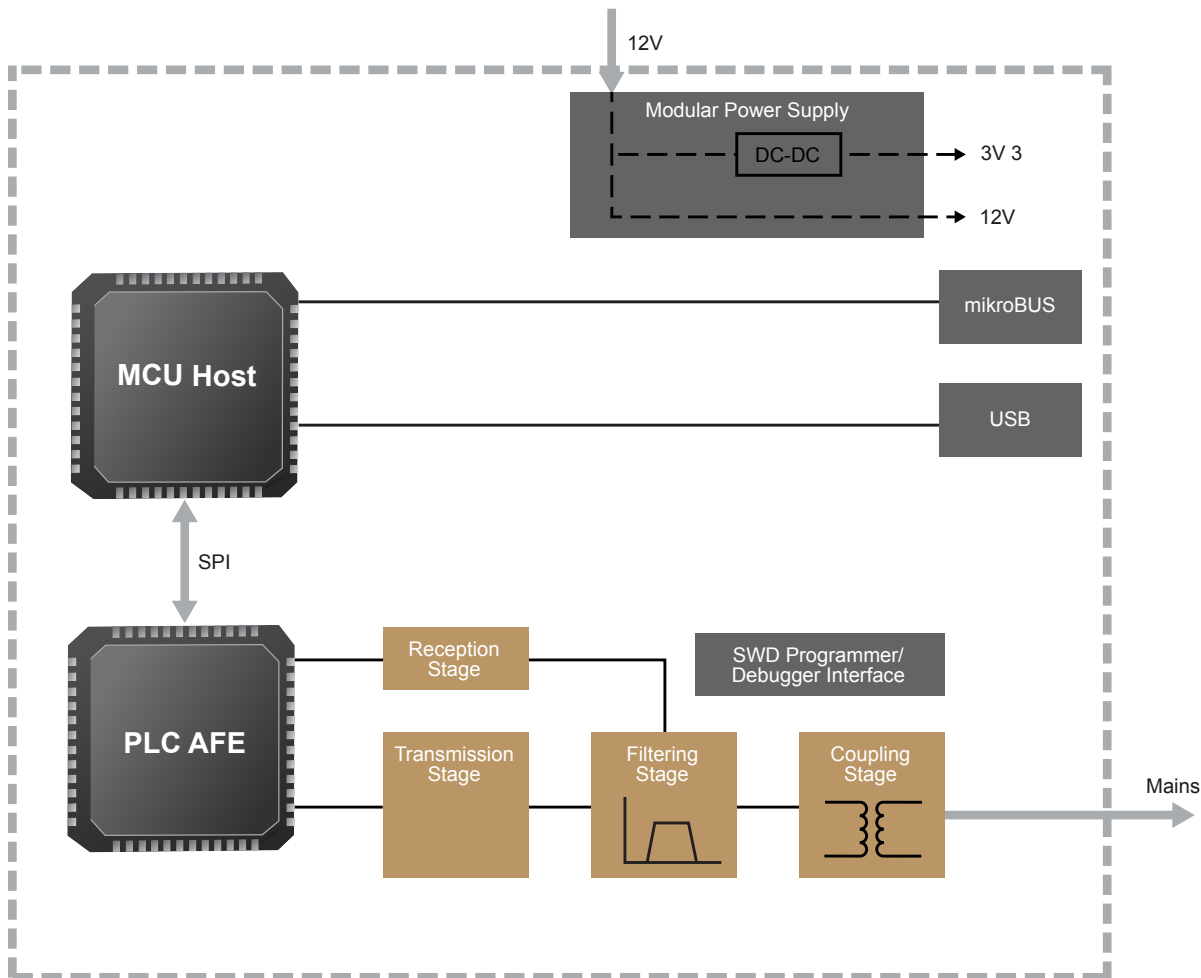

Microchip kits PL360G55CB-EK and PL360G55CF-EK are available for evaluation. Please contact plc@microchip.com for additional information and design resources.

Wireless Connectivity Products

Efficient smart energy wireless applications require both high-performance and power efficiency. Microchip transceivers deliver the leading RF link budget with the industry's lowest power consumption.

Additionally, Microchip offers the most feature-rich IEEE 802.15.4-compliant transceiver family available. Our transceivers support regional sub-1 GHz bands, as well as the global 2.4 GHz band. This enables you to develop wireless applications for customers worldwide, including emerging markets like China.

Enhanced Performance

Powerful hardware features like antenna diversity or external power amplifier support let you further boost transceiver performance to maximize network reliability and RF range of your system. Microchip transceivers support not only IEEE 802.15.4-compliant applications, but provide on-air data rates up to 2 Mbps for general purpose Industrial Scientific Medical (ISM) applications. Pin compatibility ensures an easy transition between devices or frequency bands.

To help you speed up system development and prototyping, Microchip offers a variety of free software suites, various hardware evaluation boards and development kits and modules.

Wireless Transceiver Application Diagram

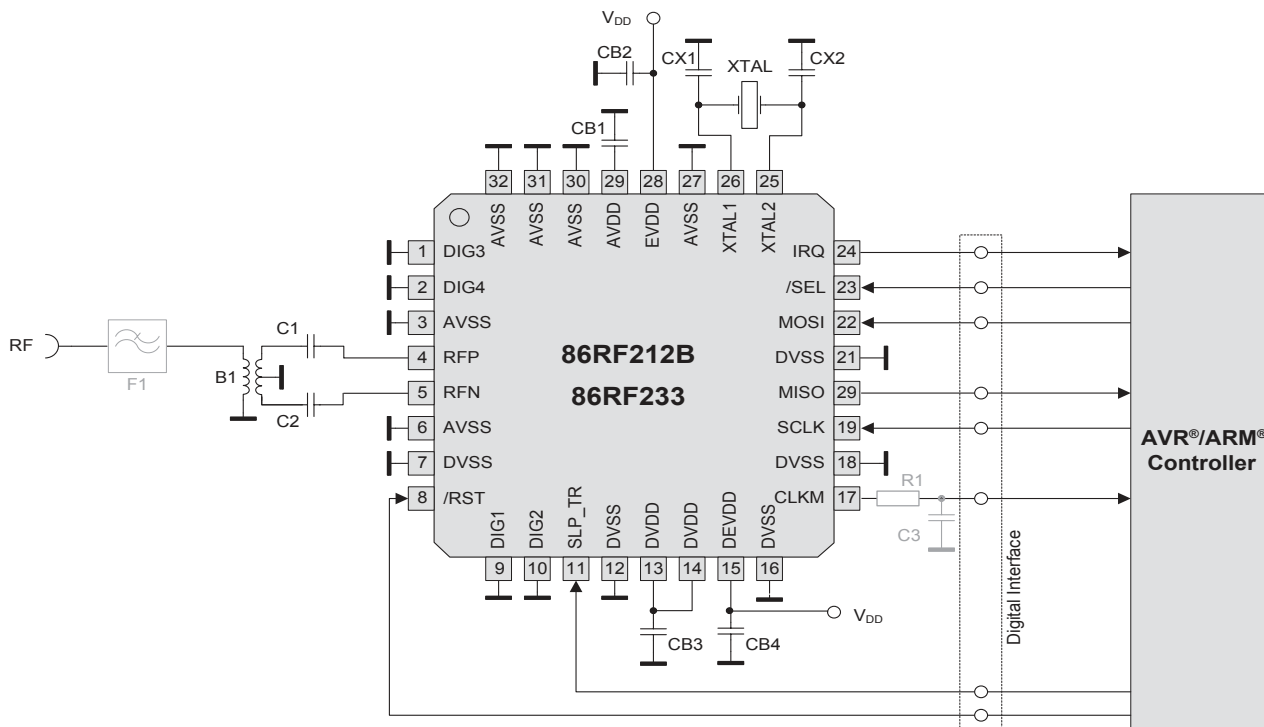

Key Products

The 86RF212B is a low-power, low-voltage RF transceiver for the regional 700/800/900 MHz frequency bands available in Japan, China, Europe and North America. This transceiver offers an extremely good 120 dB link budget (-110 dBm receiver sensitivity/ $+10$ dBm transmit power) designed for low-cost IEEE 802.15.4, zigbee® and high data rate ISM applications.

The 86RF233 transceiver is designed to operate in the 2.4 GHz ISM band, available worldwide. This transceiver offers link budgets up to 105 dB (-101 dBm receiver sensitivity/ $+4$ dBm transmit power). For a complete overview of features, key parameters and targeted application areas, please see the data sheet.

86RF215 is a dual-band sub-1 GHz/2.4 GHz transceiver compliant to IEEE 802.15.4-2011, IEEE 802.15.4g-2012 and ETSI TS 102 887-1. This device offers very high flexibility by supporting a variety of data rates with three modulation schemes: multi-rate and multi-regional frequency shift keying (MR-FSK), orthogonal frequency division multiplexing (MR-OFDM), as well as offset quadrature phase-shift keying (MR-O-QPSK). This includes the physical layer which is used for zigbee PRO and IP. With an output power of 14 dBm and receiver sensitivities down to -123 dBm, link budgets up to 137 dB can be achieved.

RF215 Block Diagram

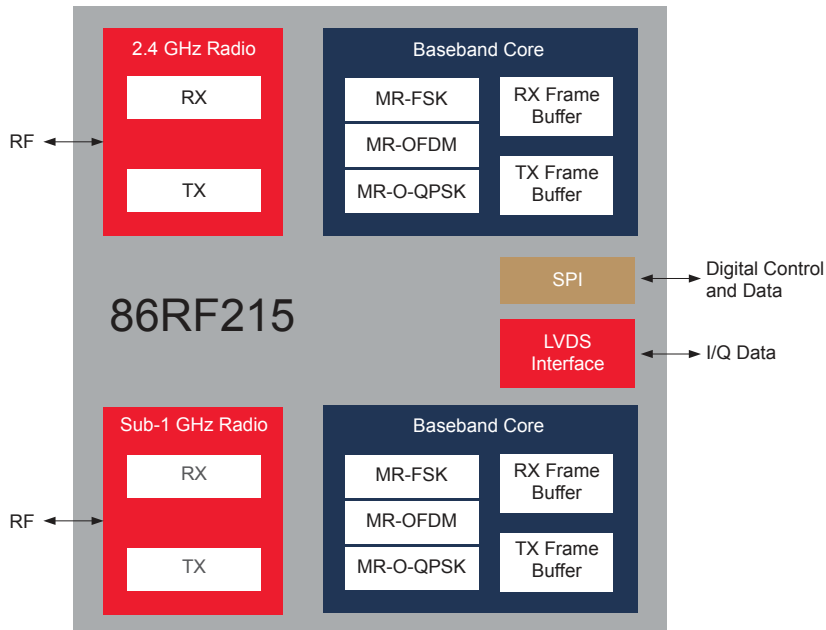

Device	Band (MHz)	Modulation	Data Rate, (kbit/s)	RX, Sens, (dBm)	Max. TX Power (dBm)	Current: SLEEP, TRX_OFF, RX_ON, BUSY_TX	Pack.	Compliance
86RF212B Transceiver	769... 935	BPSK, O-QPSK	20, 40, 100, 250 <i>proprietary:</i> 200, 400, 500, 1000	-110 @ 20 kbps	10	0.2 μ A, 0.4 mA, 9.2 mA, 17.0 mA @ 5 dBm	32-pin QFN	IEEE 802.15.4- 2006, IEEE 802.15.4-2011
86RF233 Transceiver	2322... 2527	O-QPSK	250 <i>proprietary:</i> 500, 1000, 2000	-101 @ 250 kbps	4	0.02/0.2 μ A, 0.3 mA, 6.0/11.8 mA, 13.8 mA @ 4 dBm	32-pin QFN	IEEE 802.15.4- 2006, IEEE 802.15.4-2011
86RF215 Transceiver and I/Q radio	389 ...510 779 ...1020 2400 ...2483	MR-FSK, MR-OFDM, MR-O- QPSK, O-QPSK	6.25 ... 800 <i>proprietary</i> <i>up to 2400</i>	-123 @ 6.25 kbps	14	30 nA, 3.0 mA, 28 mA, 65 mA @ 14 dBm	48-pin QFN	IEEE 802.15.4- 2006, IEEE 802.15.4-2011, IEEE 802.15.4g- 2012, ETSI TS 102 887-1
86RF215M Transceiver and I/Q radio	389 ...510 779 ...102	MR-FSK, MR-OFDM, MR-O QPSK, O-QPSK	6.25 ... 800 <i>proprietary</i> <i>up to 2400</i>	-123 @ 6.25 kbps	14	30 nA, 3.0 mA, 28 mA, 65 mA @ 14 dBm	48-pin QFN	IEEE 802.15.4- 2011, IEEE 802.15.4g-2012, ETSI TS 102 887-1

		Product	Ordering Code	Package	Features	Flash	Carrier	
Metering MCU	SAM4C4C		ATSAM4C4CB-AU	100-pin LQFP	Green, IND TEMP, CRYPTO	256 KB	Tray	
			ATSAM4C4CB-AUR	100-pin LQFP	Green, IND TEMP, CRYPTO	256 KB	Tape & Reel	
	SAM4C8C		ATSAM4C8CB-AU	100-pin LQFP	Green, IND TEMP, CRYPTO	512 KB	Tray	
			ATSAM4C8CB-AUR	100-pin LQFP	Green, IND TEMP, CRYPTO	512 KB	Tape & Reel	
	SAM4C16C		ATSAM4C16CB-AU	100-pin LQFP	Green, IND TEMP, CRYPTO	1 MB	Tray	
			ATSAM4C16CB-AUR	100-pin LQFP	Green, IND TEMP, CRYPTO	1 MB	Tape & Reel	
	SAM4C32CA		ATSAM4C32CA-AU	100-pin LQFP	Green, IND TEMP, CRYPTO	2 MB	Tray	
			ATSAM4C32CA-AUR	100-pin LQFP	Green, IND TEMP, CRYPTO	2 MB	Tape & Reel	
	SAM4C32EA		ATSAM4C32EA-AU	144-pin LQFP	Green, IND TEMP, CRYPTO	2 MB	Tray	
			ATSAM4C32EA-AUR	144-pin LQFP	Green, IND TEMP, CRYPTO	2 MB	Tape & Reel	
Metrology SoC	1 Phase	SAM4CMS4C		ATSAM4CMS4CC-AU	100-pin LQFP	Green, IND TEMP, CRYPTO	256 KB	Tray
				ATSAM4CMS4CC-AUR	100-pin LQFP	Green, IND TEMP, CRYPTO	256 KB	Tape & Reel
		SAM4CMS8C		ATSAM4CMS8CC-AU	100-pin LQFP	Green, IND TEMP, CRYPTO	512 KB	Tray
				ATSAM4CMS8CC-AUR	100-pin LQFP	Green, IND TEMP, CRYPTO	512 KB	Tape & Reel
		SAM4CMS16C		ATSAM4CMS16CC-AU	100-pin LQFP	Green, IND TEMP, CRYPTO	1 MB	Tray
				ATSAM4CMS16CC-AUR	100-pin LQFP	Green, IND TEMP, CRYPTO	1 MB	Tape & Reel
	SAM4CMS32C		ATSAM4CMS32CB-AU	100-pin LQFP	Green, IND TEMP, CRYPTO	2 MB	Tray	
			ATSAM4CMS32CB-AUR	100-pin LQFP	Green, IND TEMP, CRYPTO	2 MB	Tape & Reel	
	3 Phase	SAM4CMP8C		ATSAM4CMP8CC-AU	100-pin LQFP	Green, IND TEMP, CRYPTO	512 KB	Tray
				ATSAM4CMP8CC-AUR	100-pin LQFP	Green, IND TEMP, CRYPTO	512 KB	Tape & Reel
		SAM4CMP16C		ATSAM4CMP16CC-AU	100-pin LQFP	Green, IND TEMP, CRYPTO	1 MB	Tray
				ATSAM4CMP16CC-AUR	100-pin LQFP	Green, IND TEMP, CRYPTO	1 MB	Tape & Reel
		SAM4CMP32C		ATSAM4CMP32CB-AU	100-pin LQFP	Green, IND TEMP, CRYPTO	2 MB	Tray
				ATSAM4CMP32CB-AUR	100-pin LQFP	Green, IND TEMP, CRYPTO	2 MB	Tape & Reel









	Ordering Code	Kit Contents Pictures	IDE	RTOS	STACKS/LIBRARIES
Tools	ATSAM4C-EK		Atmel Studio & ASF IAR KEIL	FreeRTOS	Microchip Metrology & Crypto Libraries
	ATSAM4C32-EK				
Tools	ATSAM4CMS32-DB		Atmel Studio & ASF IAR KEIL	FreeRTOS	Microchip Metrology & Crypto Libraries
	ATSAM4CMS-DB				
	ATSAM4CMP-DB				
	ATSAM4CMP32-DB				

	Product	Ordering Code	Package	Features	Flash	Carrier	
PLC	Multi-protocol Modem	PL360	MPL360B-I/SCB	48-pin QFN	Green, IND TEMP	–	Tray
			MPL360BT-I/SCB	48-pin QFN	Green, IND TEMP	–	Tape & Reel
			MPL360B-I/Y8X	48-pin TQFP	Green, IND TEMP	–	Tray
			MPL360BT-I/Y8X	48-pin TQFP	Green, IND TEMP	–	Tape & Reel
	PRIME Modem	PL230A*	ATPL230A-AKU-Y	80-pin LQFP	Green, IND TEMP	–	Tray
			ATPL230A-AKU-R	80-pin LQFP	Green, IND TEMP	–	Tape & Reel
	PRIME SoC	SAM4CP16B	ATSAM4CP16B-AHU-Y	176-pin LQFP	Green, IND TEMP	1 MB	Tray
	G3 Modem	PL250A*	ATPL250A-AKU-Y	80-pin LQFP	Green, IND TEMP	–	Tray
			ATPL250A-AKU-R	80-pin LQFP	Green, IND TEMP	–	Tape & Reel
	G3 SoC	SAM4CP16C	ATSAM4CP16C-AHU-Y	176-pin LQFP	Green, IND TEMP	1 MB	Tray
RF	Sub-1 GHz Transceiver (IEEE 802.15.4-2011)	86RF212B	AT86RF212B-ZU	32-pin QFN	700/800/900 MHz Transceiver, 85°C	–	Tray
			AT86RF212B-ZUR	32-pin QFN	700/800/900 MHz Transceiver, 85°C	–	Tape & Reel
	2.4 GHz Transceiver (IEEE 802.15.4-2006)	86RF233	AT86RF233-ZF	32-pin QFN	2.4 GHz Transceiver, 125°C	–	Tray
			AT86RF233-ZFR	32-pin QFN	2.4 GHz Transceiver, 125°C	–	Tape & Reel
			AT86RF233-ZU	32-pin QFN	2.4 GHz Transceiver, 85°C	–	Tray
			AT86RF233-ZUR	32-pin QFN	2.4 GHz Transceiver, 85°C	–	Tape & Reel
	Dual-Band Transceiver (IEEE 802.15.4g-2012)	86RF215	AT86RF215-ZU	48-pin QFN	Dual-Band Transceiver, 85°C	–	Tray
			AT86RF215-ZUR	48-pin QFN	Dual-Band Transceiver, 85°C	–	Tape & Reel
	Sub-1 GHz Transceiver (IEEE 802.15.4g-2012)	86RF215M	AT86RF215M-ZU	48-pin QFN	Sub-1 GHz Transceiver, 85°C	–	Tray
			AT86RF215M-ZUR	48-pin QFN	Sub-1 GHz Transceiver, 85°C	–	Tape & Reel
	Dual-Band I/Q Radio	86RF215IQ	AT86RF215IQ-ZU	48-pin QFN	Dual-Band I/Q Radio, 85°C	–	Tray
			AT86RF215IQ-ZUR	48-pin QFN	Dual-Band I/Q Radio, 85°C	–	Tape & Reel

*Not recommended for new designs

	Ordering Code	Kit Contents Pictures			IDE	RTOS	STACKS/LIBRARIES
Tools	ATPL360-EK (2 Modem Boards + 4 Couplings)				Atmel Studio, ASF, IAR and Keil	FreeRTOS	PRIME PLC < 500 kHz G3 PLC < 500 kHz
	ATPL230A-EK (2 Modem Boards + 4 Couplings)	2x 	2x 	2x 	Atmel Studio, ASF, IAR and Keil	FreeRTOS	PRIME PLC < 500 kHz
	ATSAM4CP16B-EK (2 Boards + 4 Couplings)	2x 	2x 	2x 	Atmel Studio, ASF, IAR and Keil	FreeRTOS	PRIME PLC < 500 kHz
	ATPL250A-EK (2 Modem Boards + 4 Couplings)	2x 	2x 	2x 	Atmel Studio, ASF, IAR and Keil	FreeRTOS	G3 PLC < 500 kHz
	PL360G55CB-EK (1 Board)				Atmel Studio, IAR, Keil	FreeRTOS	G3-PLC in CENELEC-B (95 .. 125 kHz)
	PL360G55CF-EK (1 board)				Atmel Studio, IAR, Keil	FreeRTOS	PLC in CENELEC-A (9..95 kHz) + FCC (150..500 kHz)
	ATSAM4CP16C-EK (2 Boards + 4 Couplings)	2x 	2x 	2x 	Atmel Studio, ASF, IAR and Keil	FreeRTOS	G3 PLC < 500 kHz
Tools	ATSAM4L-EK + ATZB212B-XPRO				Atmel Studio ASF Wireless Performance Analyzer	FreeRTOS eCOS (SAM9)	Exegin Technologies: IEEE 802.15.4 MAC, zigbee® Pro/SEP1.x, zigbee IP/SEP2.0, 6LoWPAN
	ATSAM4L-EK/ATSAM4S-XPRO + ATREB233-XPRO or ATZB-A-233-XPRO (Amplified)						
	ATSAM4L-EK/ATSAM4S-XPRO + ATREB215-XPRO						
	ATREB215-XPRO				N/A	N/A	N/A

		Product	Ordering Code	Package	Features	Flash	Carrier
SAM4C AFE Companion Chip	1 Phase	SENSE100	ATSENSE101A-SU	20-pin SOIC	GREEN, IND TEMP	-	Tube
			ATSENSE101A-SUR	20-pin SOIC	GREEN, IND TEMP	-	Tape & Reel
	2 Phase	SENSE200	ATSENSE201A-AU	32-pin LQFP	GREEN, IND TEMP	-	Tube
			ATSENSE201A-AUR	32-pin LQFP	GREEN, IND TEMP	-	Tape & Reel
			ATSENSE201HA-AU	32-pin LQFP	GREEN, IND TEMP	-	Tube
			ATSENSE201HA-AUR	32-pin LQFP	GREEN, IND TEMP	-	Tape & Reel
	3 Phase	SENSE300	ATSENSE301A-AU	32-pin LQFP	GREEN, IND TEMP	-	Tube
			ATSENSE301A-AUR	32-pin LQFP	GREEN, IND TEMP	-	Tape & Reel
			ATSENSE301HA-AU	32-pin LQFP	GREEN, IND TEMP	-	Tube
			ATSENSE301HA-AUR	32-pin LQFP	GREEN, IND TEMP	-	Tape & Reel
			ATSENSE301A-AN	32-pin LQFP	GREEN, IND TEMP	-	Tube
			ATSENSE301A-ANR	32-pin LQFP	GREEN, IND TEMP	-	Tape & Reel
AFE Companion Chip	1 Phase 2 Phase (shunt) 3 Phase (shunt)	MCP3910	MCP3910A1-E/ML	20-pin QFN	GREEN, EXT TEMP	-	Tube
			MCP3910A1T-E/ML	20-pin QFN	GREEN, EXT TEMP	-	Tape & Reel
			MCP3910A1-E/SS	20-pin SSOP	GREEN, EXT TEMP	-	Tube
			MCP3910A1T-E/SS	20-pin SSOP	GREEN, EXT TEMP	-	Tape & Reel
		MCP3918	MCP3918A1-E/ML	20-pin QFN	GREEN, EXT TEMP	-	Tube
			MCP3918A1T-E/ML	20-pin QFN	GREEN, EXT TEMP	-	Tape & Reel
			MCP3918A1-E/SS	20-pin SSOP	GREEN, EXT TEMP	-	Tube
			MCP3918A1T-E/SS	20-pin SSOP	GREEN, EXT TEMP	-	Tape & Reel
	MCP3919	MCP3919A1-E/MQ	28-pin QFN	GREEN, EXT TEMP	-	Tube	
		MCP3919A1T-E/MQ	28-pin QFN	GREEN, EXT TEMP	-	Tape & Reel	
		MCP3919A1-E/SS	28-pin SSOP	GREEN, EXT TEMP	-	Tube	
		MCP3912A1T-E/SS	28-pin SSOP	GREEN, EXT TEMP	-	Tape & Reel	
	2 Phase	MCP3912t	MCP3912A1-E/MQ	28-pin QFN	GREEN, EXT TEMP	-	Tube
			MCP3912A1T-E/MQ	28-pin QFN	GREEN, EXT TEMP	-	Tape & Reel
			MCP3912A1-E/SS	28-pin SSOP	GREEN, EXT TEMP	-	Tube
			MCP3912A1T-E/SS	28-pin SSOP	GREEN, EXT TEMP	-	Tape & Reel
	3 Phase	MCP3913	MCP3913A1-E/MV	40-pin UQFN	GREEN, EXT TEMP	-	Tube
			MCP3913A1T-E/MV	40-pin UQFN	GREEN, EXT TEMP	-	Tape & Reel
			MCP3913A1-E/SS	28-pin SSOP	GREEN, EXT TEMP	-	Tube
			MCP3913A1T-E/SS	28-pin SSOP	GREEN, EXT TEMP	-	Tape & Reel
MCP3914		MCP3914A1-E/MV	40-pin UQFN	GREEN, EXT TEMP	-	Tube	
		MCP3914A1T-E/MV	40-pin UQFN	GREEN, EXT TEMP	-	Tape & Reel	
Stand Alone AFE (90E series)	1 Phase	M90E26	ATM90E26-YU-B	28-pin SSOP	IND TEMP, 1.8V/3V	-	Tube
			ATM90E26-YU-R	28-pin SSOP	IND TEMP, 1.8V/3V	-	Tape & Reel
	3 Phase	M90E32	ATM90E32AS-AU-R	48-pin TQFP	IND TEMP, 1.8V/3V	-	Tape & Reel
			ATM90E32AS-AU-Y	48-pin TQFP	IND TEMP, 1.8V/3V	-	Tray
		M90E36	ATM90E36A-AU-R	48-pin TQFP	IND TEMP, 1.8V/3V	-	Tape & Reel
			ATM90E36A-AU-Y	48-pin TQFP	IND TEMP, 1.8V/3V	-	Tray

	Ordering Code	Kit Contents Pictures	IDE	RTOS	Stacks/Libraries
Tools		Use Metrology SoC Tools			
	ADM00425				Contact Microchip
	ADM00573				
	ADM00499				
	ADM00522				
	ADM00523				
Tools	ATM90E2X-DB		All SAM4C Software tools + Metrology Libraries		
	ATM90E32AS-DB		All SAM4C Software tools + Metrology Libraries		
	ATM90E36A-DB		All SAM4C Software tools + Metrology Libraries		

Support

Microchip is committed to supporting its customers in developing products faster and more efficiently. We maintain a worldwide network of field applications engineers and technical support ready to provide product and system assistance. For more information, please visit www.microchip.com:

- Technical Support: www.microchip.com/support
- Evaluation samples of any Microchip device: www.microchip.com/samples
- Knowledge base and peer help: www.microchip.com/forums
- Sales and Global Distribution: www.microchip.com/sales

Training

If additional training interests you, Microchip offers several resources including in-depth technical training and reference material, self-paced tutorials and significant online resources.

- Overview of Technical Training Resources: www.microchip.com/training
- MASTERS Conferences: www.microchip.com/masters
- Developer Help Website: www.microchip.com/developerhelp
- Technical Training Centers: www.microchip.com/seminars

Sales Office Listing

AMERICAS

Atlanta, GA
Tel: 678-957-9614

Austin, TX
Tel: 512-257-3370

Boston, MA
Tel: 774-760-0087

Chandler, AZ (HQ)
Tel: 480-792-7200

Chicago, IL
Tel: 630-285-0071

Dallas, TX
Tel: 972-818-7423

Detroit, MI
Tel: 248-848-4000

Houston, TX
Tel: 281-894-5983

Indianapolis, IN
Tel: 317-773-8323
Tel: 317-536-2380

Los Angeles, CA
Tel: 949-462-9523
Tel: 951-273-7800

Raleigh, NC
Tel: 919-844-7510

New York, NY
Tel: 631-435-6000

San Jose, CA
Tel: 408-735-9110
Tel: 408-436-4270

Canada - Toronto
Tel: 905-695-1980

EUROPE

Austria - Wels
Tel: 43-7242-2244-39

Denmark - Copenhagen
Tel: 45-4450-2828

Finland - Espoo
Tel: 358-9-4520-820

France - Paris
Tel: 33-1-69-53-63-20

Germany - Garching
Tel: 49-8931-9700

Germany - Haan
Tel: 49-2129-3766-400

Germany - Heilbronn
Tel: 49-7131-67-3636

Germany - Karlsruhe
Tel: 49-721-62537-0

Germany - Munich
Tel: 49-89-627-144-0

Germany - Rosenheim
Tel: 49-8031-354-560

EUROPE

Israel - Ra'anana
Tel: 972-9-744-7705

Italy - Milan
Tel: 39-0331-742611

Italy - Padova
Tel: 39-049-7625286

Netherlands - Drunen
Tel: 31-416-690399

Norway - Trondheim
Tel: 47-7289-7561

Poland - Warsaw
Tel: 48-22-3325737

Romania - Bucharest
Tel: 40-21-407-87-50

Spain - Madrid
Tel: 49-91-708-08-90

Sweden - Gothenberg
Tel: 46-31-704-60-40

Sweden - Stockholm
Tel: 46-8-5090-4654

UK - Wokingham
Tel: 44-118-921-5800

ASIA/PACIFIC

Australia - Sydney
Tel: 61-2-9868-6733

China - Beijing
Tel: 86-10-8569-7000

China - Chengdu
Tel: 86-28-8665-5511

China - Chongqing
Tel: 86-23-8980-9588

China - Dongguan
Tel: 86-769-8702-9880

China - Guangzhou
Tel: 86-20-8755-8029

China - Hangzhou
Tel: 86-571-8792-8115

China - Hong Kong SAR
Tel: 852-2943-5100

China - Nanjing
Tel: 86-25-8473-2460

China - Qingdao
Tel: 86-532-8502-7355

China - Shanghai
Tel: 86-21-3326-8000

China - Shenyang
Tel: 86-24-2334-2829

China - Shenzhen
Tel: 86-755-8864-2200

China - Suzhou
Tel: 86-186-6233-1526

China - Wuhan
Tel: 86-27-5980-5300

China - Xiamen
Tel: 86-592-2388138

China - Xian
Tel: 86-29-8833-7252

ASIA/PACIFIC

China - Zhuhai
Tel: 86-756-321-0040

India - Bangalore
Tel: 91-80-3090-4444

India - New Delhi
Tel: 91-11-4160-8631

India - Pune
Tel: 91-20-4121-0141

Japan - Osaka
Tel: 81-6-6152-7160

Japan - Tokyo
Tel: 81-3-6880-3770

Korea - Daegu
Tel: 82-53-744-4301

Korea - Seoul
Tel: 82-2-554-7200

Malaysia - Kuala Lumpur
Tel: 60-3-7651-7906

Malaysia - Penang
Tel: 60-4-227-8870

Philippines - Manila
Tel: 63-2-634-9065

Singapore
Tel: 65-6334-8870

Taiwan - Hsin Chu
Tel: 886-3-577-8366

Taiwan - Kaohsiung
Tel: 886-7-213-7830

Taiwan - Taipei
Tel: 886-2-2508-8600

Thailand - Bangkok
Tel: 66-2-694-1351

Vietnam - Ho Chi Minh
Tel: 84-28-5448-2100

8/15/18



www.microchip.com

Microchip Technology Inc. | 2355 W. Chandler Blvd. | Chandler AZ, 85224-6199