

MAXIM

MAX4223 Evaluation Kit

General Description

The MAX4223 evaluation kit (EV kit) simplifies evaluation of the 1GHz, low-power MAX4223 current-feedback amplifier. The EV kit circuit demonstrates the MAX4223 in the noninverting unity-gain configuration. RF-style connectors (SMA) and 50Ω terminating resistors are included for test equipment compatibility.

The MAX4223 EV kit uses a PC board design optimized for high-frequency amplifiers. This board can also be used to evaluate the MAX4224 and other Maxim amplifiers that share the same pinout.

Component List

DESIGNATION	QTY	DESCRIPTION
C1, C2	2	0.1μF, 10% ceramic capacitors
C3, C4	2	10μF, 10V, 20% tantalum capacitors AVX TAJB106M010 or Sprague 293D106X0010B
R1, R2	2	49.9Ω, 1% resistors
RF	1	560Ω, 5% resistor
RG	0	Open
IN, OUT	2	SMA connectors
U1	1	MAX4223ESA
JU1	1	3-pin header
None	1	Shunt for JU1
None	1	PC board
None	1	MAX4223 data sheet

Component Suppliers

SUPPLIER	PHONE	FAX
AVX	(803) 946-0690	(803) 626-3123
Sprague	(603) 224-1961	(603) 224-1430

Note: Please indicate that you are using the MAX4223 when contacting these component suppliers.

Features

- ◆ 1GHz -3dB Bandwidth
- ◆ 300MHz 0.1dB Gain Flatness
- ◆ 1100V/μs Slew Rate
- ◆ ±5V Supply Operation
- ◆ Optional Adjustable Gain
- ◆ High-Impedance Shutdown Mode
- ◆ Fully Assembled and Tested

Ordering Information

PART	TEMP. RANGE	BOARD TYPE
MAX4223EVKIT-SO	-40°C to +85°C	Surface Mount

Note: To evaluate the MAX4224, request a MAX4224ESA free sample.

Quick Start

The MAX4223 EV kit is fully assembled and tested. Follow these steps to verify board operation.

- 1) The circuit requires supply voltages of ±2.85V to ±5.5V. For evaluation purposes, connect a +5V supply to the pad labeled VCC and a -5V supply to the pad labeled VEE. Connect the power-supply ground to the pad labeled GND.
- 2) Verify that the shunt is across pins 1 and 2 of jumper JU1.
- 3) Connect the output labeled OUT to an oscilloscope input. For best performance, terminate the output with a 50Ω load.
- 4) Turn on the power supply. Apply a signal of ±2.5V maximum to the SMA connector labeled IN.
- 5) Verify the output signal on the oscilloscope.

Note: When using a 50Ω-terminated oscilloscope input, the output amplitude observed will be half that of the input, due to the voltage divider formed by the 49.9Ω back-terminating resistor (R1) and the oscilloscope input termination impedance.

Evaluates: MAX4223/MAX4224



Maxim Integrated Products 1

For free samples & the latest literature: <http://www.maxim-ic.com>, or phone 1-800-998-8800.
For small orders, phone 408-737-7600 ext. 3468.

MAX4223 Evaluation Kit

Detailed Description

Shutdown Control

The MAX4223 provides a shutdown pin ($\overline{\text{SHDN}}$) to enable or disable the output. Table 1 lists the options available for the shutdown control jumper, JU1. To use an external controller, remove the shunt on JU1 completely and connect the external controller to the pad labeled $\overline{\text{SHDN}}$. $\overline{\text{SHDN}}$ is a TTL/CMOS logic-level input.

Table 1. Jumper JU1 Functions

SHUNT LOCATION	MAX4223 $\overline{\text{SHDN}}$ PIN	MAX4223 OUTPUT
1 & 2	Connected to V_{CC}	Enabled
2 & 3	Connected to GND	Disabled

Voltage Gain Adjustment

The MAX4223 is optimized for applications requiring a gain of +1 (0dB) or greater. Its gain can be set by changing the feedback (R_F) and gain-set (R_G) resistors. For improved performance at a gain of +2 (6dB) or greater, replace the MAX4223 with a free sample of the MAX4224. Refer to the MAX4223–MAX4228 data sheet for recommended feedback-resistor values.

Layout Considerations

The PC board layout has been optimized for high-speed signals and low distortion, with careful attention given to grounding, power-supply bypassing, and signal-path layout. The small, surface-mount, ceramic bypass capacitors (C1 and C2) have been placed as close to the amplifier's supply pins as possible. The ground plane has been removed around and under the amplifier to reduce stray capacitance. Capacitance at the inverting input pins has been minimized by reducing the length and width of the input and feedback traces, and by using 0805-size surface-mount feedback and gain-set resistors.

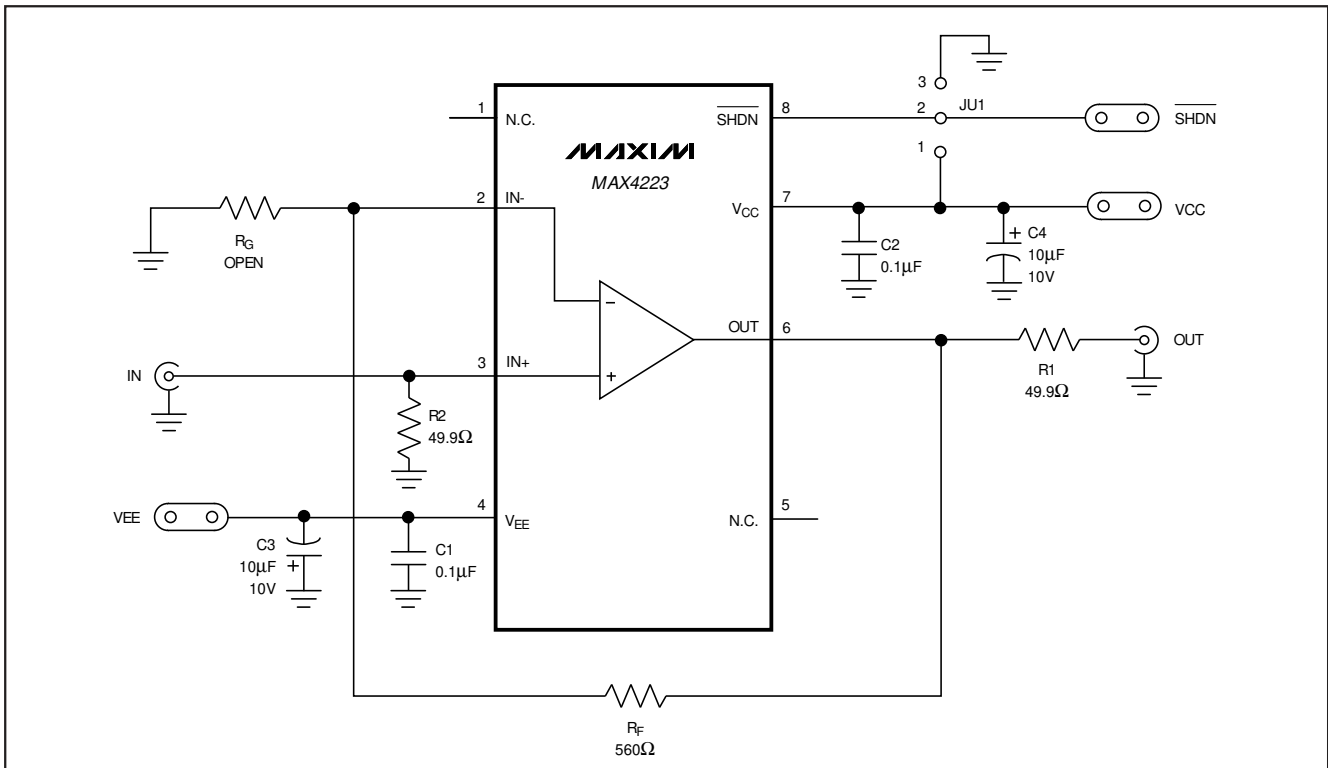

Figure 1. MAX4223 EV Kit Schematic

MAX4223 Evaluation Kit

Evaluates: MAX4223/MAX4224

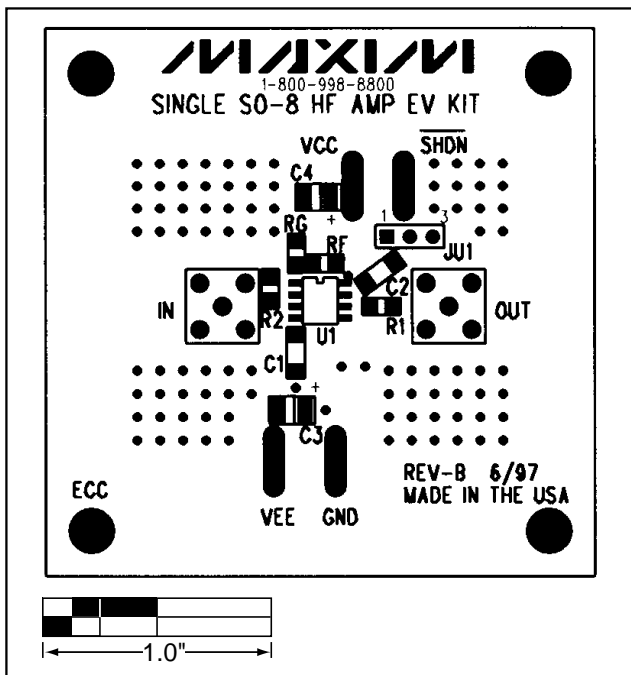

Figure 2. MAX4223 EV Kit Component Placement Guide

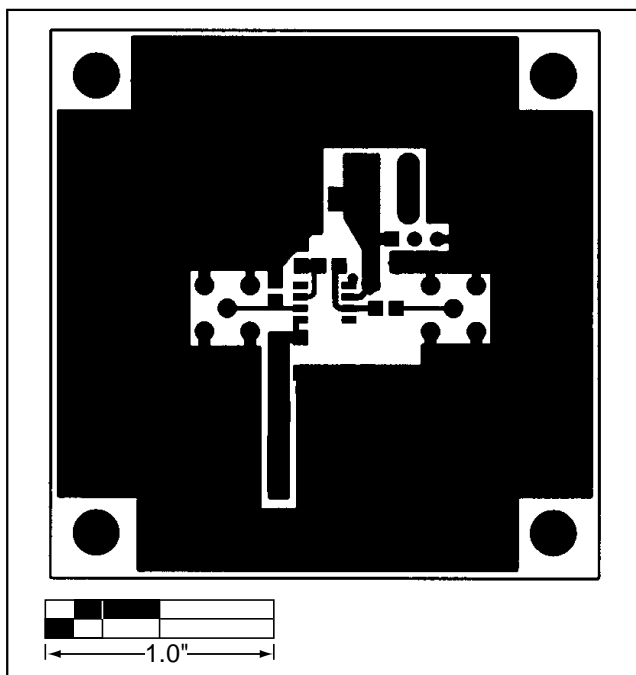

Figure 3. MAX4223 EV Kit PC Board Layout—Component Side

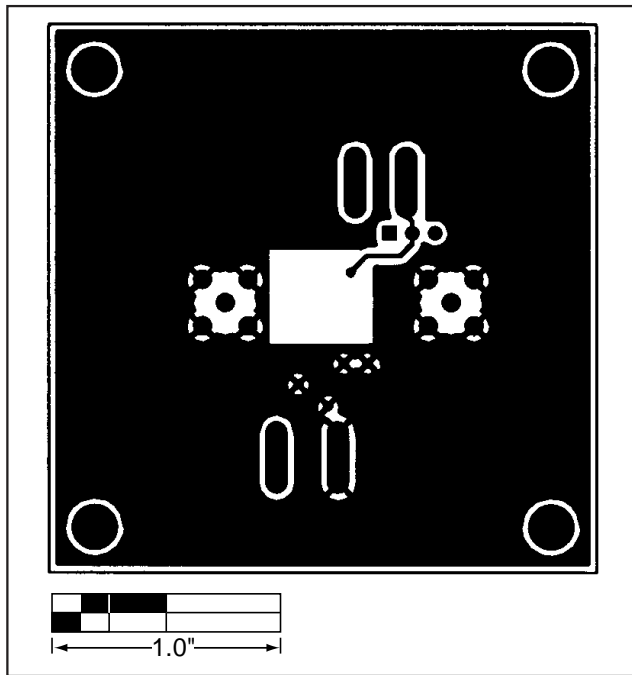

Figure 4. MAX4223 EV Kit PC Board Layout—Solder Side

MAX4223 Evaluation Kit

Evaluates: MAX4223/MAX4224

NOTES

Maxim cannot assume responsibility for use of any circuitry other than circuitry entirely embodied in a Maxim product. No circuit patent licenses are implied. Maxim reserves the right to change the circuitry and specifications without notice at any time.

4 _____ **Maxim Integrated Products, 120 San Gabriel Drive, Sunnyvale, CA 94086 408-737-7600**

© 1997 Maxim Integrated Products

Printed USA

MAXIM is a registered trademark of Maxim Integrated Products.