

Tous droits strictement réservés. Reproduction ou communication a des tiers interdite sous quelque forme que ce soit sans autorisation écrite du propriétaire. Propriété de c FCI. Droits de reproduction FCI.

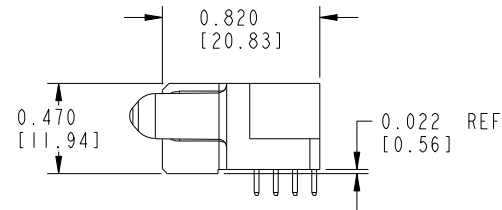

All rights strictly reserved. Reproduction or issue to third parties in any form whatever is not permitted without written authority from the proprietor. Property of FCI. Copyright FCI.

PRODUCT No.	ROWS	POWER		SIGNAL					POWER		
		E2	P2	6	5	4	3	2	1	P1	E1
51627-001	D C B A		PA	H	H	H	H	H	H	PA	
NOTE: ②				G	G	G	G	G			
				F	F	F	F	F			
				E	E	E	E	E			

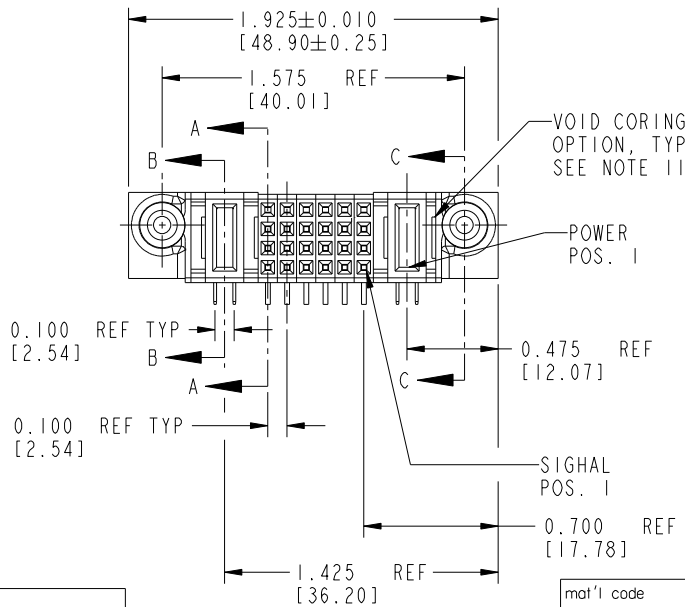
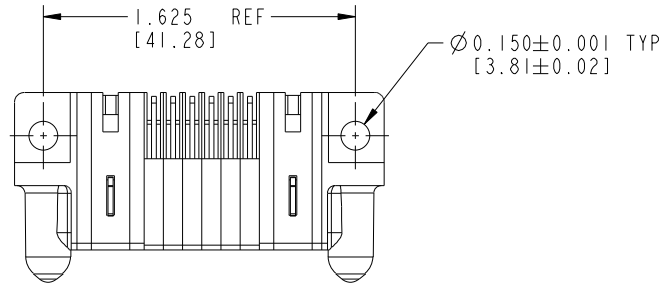

CODE	CONTACT TYPE
PA	POWER
E	SIGNAL
F	SIGNAL
G	SIGNAL
H	SIGNAL

mat'l code				SEE NOTES		tolerances unless otherwise specified		CUSTOMER COPY		 www.fciconnect.com	
ltr	ecn no.	dr	date	linear	.XX ± .01 / .X ± .3		projection			title	
A	V90870	CHB	03-30-99		.XXX ± .005 / .XX ± .13					IP + 24S + IP	
B	V90885	CHB	05-40-99		.XXX ± .0020 / .XXX ± .051					RIGHT ANGLE SOLDER RECEPTACLE	
C	V91755	SAR	08-05-99	angles	0° ± 2°		 scale 1:1	product family		code	
D	V01392	EKK	06-26-00	dr	C. BAROT	03-30-99		PWRBLADE		213	
E	V10197	LSS	04-12-01	engr	J. BROWN	03-30-99		size	dwg no	sheet	
F	DG05-0243	SJ	07/26/05	chr	J. BROWN	03-30-99		51627		1 of 4	
G	DG08-0237	W D	09/01/08	appd	J. BROWN	03-30-99					
sheet index	revision	G	G	G	G	G					
	sheet	1	2	3							

Tous droits strictement réservés. Reproduction ou communication a des tiers interdite sous quelque forme que ce soit sans autorisation écrite du propriétaire. Propriété de c FCI. Droits de reproduction FCI.

All rights strictly reserved. Reproduction or issue to third parties in any form whatever is not permitted without written authority from the proprietor. Property of FCI. Copyright FCI.



PRODUCT NUMBER
51627-001--
NOTE: ②

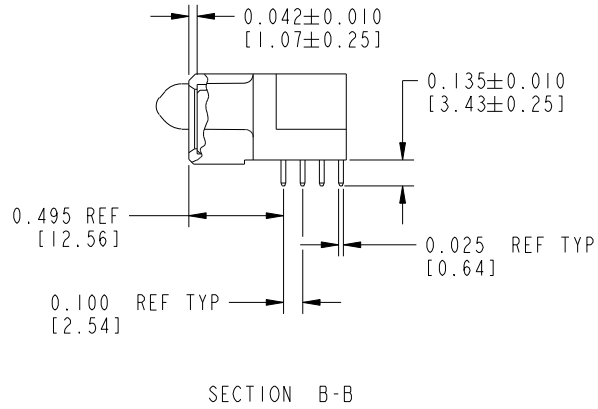
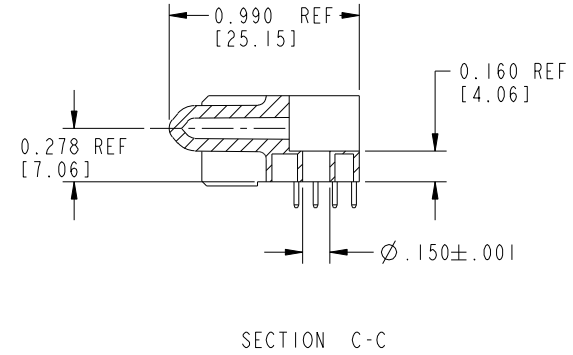
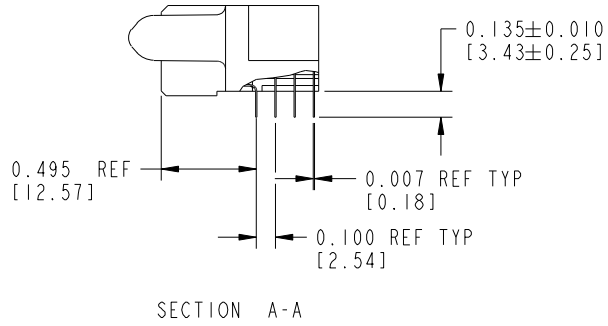

mat'l code		SEE NOTES		tolerances unless otherwise specified		CUSTOMER COPY		 www.fciconnect.com	
lfr	ecn no.	dr	date	linear	.XX ± .01 / .X ± .3	projection	title		
G					.XXX ± .005 / .XX ± .13		IP + 24S + IP		
				angles	.XXX ± .0020 / .XXX ± .051		RIGHT ANGLE SOLDER RECEPTACLE		
				dr	0° ± 2°		product family		code
				enrg	C. BAROT 03-30-99		PWRBLADE		213
				chr	J. BROWN 03-30-99	scale	size	dwg no	sheet
				appd	J. BROWN 03-30-99	1:1	A	51627	2 of 4
sheet index	revision sheet								

Pro/E

PDM: Rev:G

STAT: Released

Printed: Dec 20, 2010

cage code 28556

Tous droits strictement réservés. Reproduction ou communication a des tiers interdite sous quelque forme que ce soit sans autorisation écrite du propriétaire. Propriété de c FCI. Droits de reproduction FCI.



All rights strictly reserved. Reproduction or issue to third parties in any form whatever is not permitted without written authority from the proprietor. Property of FCI. Copyright FCI.

PRODUCT NUMBER
51627-001--
NOTE: ②

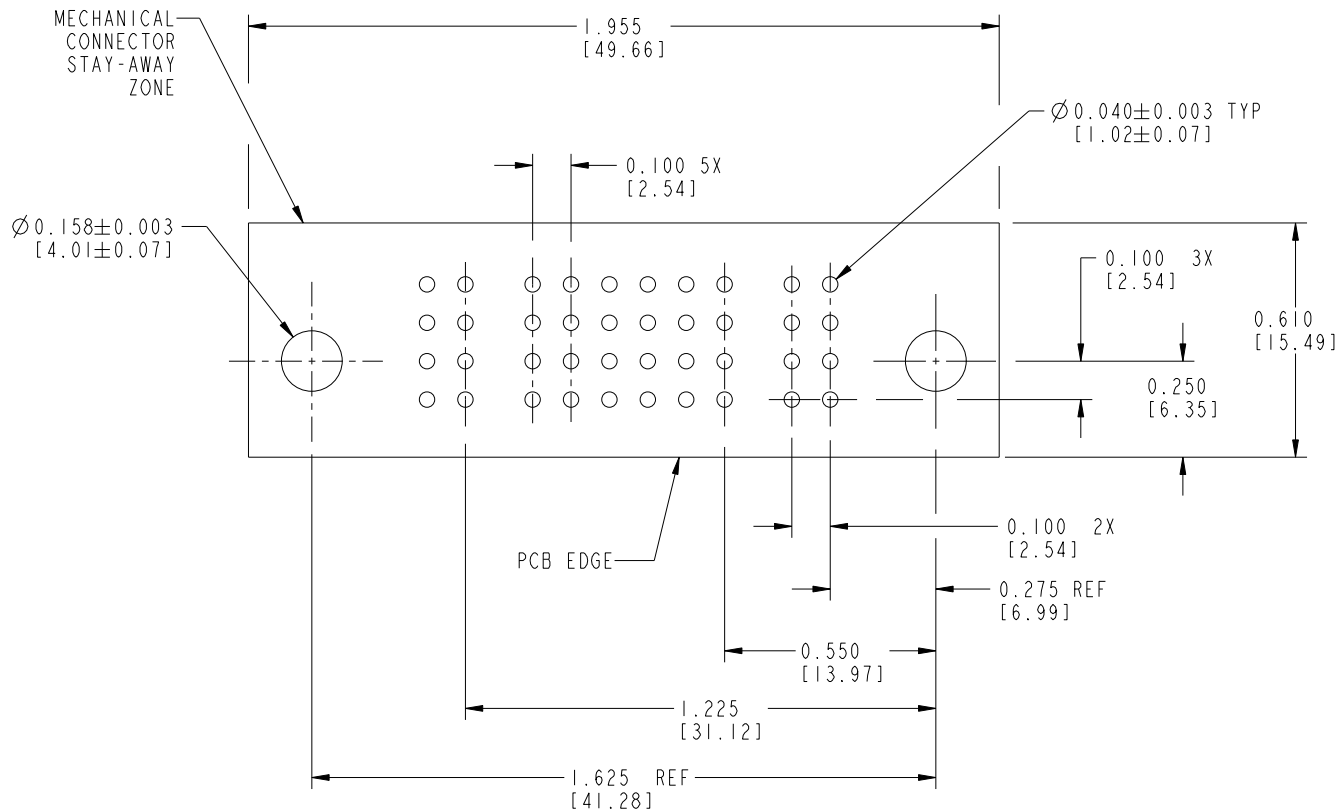

RECOMMENDED PCB LAYOUT

mat'l code		SEE NOTES		tolerances unless otherwise specified		CUSTOMER COPY		 www.fciconnect.com		
lfr	ecn no.	dr	date	linear	XX ± .01 / X ± .3		projection	title		
G					XXX ± .005 / XX ± .13				IP + 24S + IP	
					XXXX ± .0020 / XXX ± .051				RIGHT ANGLE SOLDER RECEPTACLE	
				angles	0° ± 2°		 INCH/MM scale 2:1	product family		
				dr	C. BAROT	03-30-99		PWRBLADE		
				enrg	J. BROWN	03-30-99		code	213	
				chr	J. BROWN	03-30-99		size	51627	
				appd	J. BROWN	03-30-99		dwg no	3 of 4	
sheet index	revision sheet									

Pro/E

PDM: Rev:G

STAT: Released

Printed: Dec 20, 2010

1 | 2

3 |

4

A

A

B

B

1 | 2

3 |

4

PRODUCT NUMBER
 51627-001--
 NOTE: ②

CONNECTOR NOTES:

- ① HOUSING MATERIAL: UL 94 V-0 GLASS FILLED HIGH TEMP THERMOPLASTIC
 POWER CONTACT MATERIAL: COPPER ALLOY
 SIGNAL CONTACT MATERIAL: COPPER ALLOY
- ② PLATING:
 51627-001, 51627-001LF PLATING SPEC. WAS SHOWN IN THE PRINT OF 10064183.

- 3. "MANUFACTURER" NAME, P/N, AND DATE CODE TO APPEAR ON THIS SURFACE
- 4. PRODUCT SPECIFICATION GS-12-149

PCB NOTES:

- 5. ALL DIMENSIONS ARE BASIC UNLESS OTHERWISE SPECIFIED.
- 6. ALL THROUGH HOLES ARE LOCATED WITH A TRUE POSITION OF 0.004 [0.10]
- 7. ALL HOLE DIAMETERS ARE FINISHED HOLE SIZE
- 8. $\varnothing 0.158[4.01]$ THROUGH HOLES ARE UNPLATED.
- 9. $\varnothing 0.0453 \pm 0.0010$ [1.151 ± 0.025] DRILLED HOLES PLATED WITH 0.0003 [0.008] MIN SnPb OVER 0.001 [0.03] TO 0.003 [0.08] Cu PLATING TO ACHIEVE A $\varnothing 0.040 \pm 0.003$ [1.02 ± 0.07] HOLE.
- 10. A \triangle SYMBOL WILL BE NEXT TO ANY DIMENSION, VIEW, OR NOTE WHICH HAS BEEN MODIFIED WITH THE CURRENT DRAWING REVISION.
- 11. THE VOID CORING IN BETWEEN POWER MODULES, SIGNAL MODULES AND END MOUDLES ARE OPTIONAL AND THE SHAPE MAY BE DIFFERENT FOR OPTIMIZE THE MOLDING PROCESS. THE VOID CORING WILL NOT EFFECT TO PRODUCT FUNCTION.

mat'l code		SEE NOTES		tolerances unless otherwise specified		CUSTOMER		FCI		www.fciconnect.com			
lfr	ecn no.	dr	date	linear	XX ± .01 / .X ± .3	projection		title					
G					XXX ± .005 / .XX ± .13			IP + 24S + IP RIGHT ANGLE SOLDER RECEPTACLE					
					XXXX ± .0020 / .XXX ± .051			product family					
				angles	0° ± 2°		INCH/MM	PwrBlade		code			
				dr	C. BAROT			size		dwg no	213	sheet	
				enrg	J. BROWN			04-03-99	A		51627	4 of 4	
				chr	J. BROWN			03-30-99	scale		1:1		
				appd	J. BROWN	03-30-99							
sheet index	revision sheet												

Tous droits strictement réservés. Reproduction ou communication a des tiers interdite sous quelque forme que ce soit sans autorisation écrite du propriétaire. Propriété de c FCI. Droits de reproduction FCI.



All rights strictly reserved. Reproduction or issue to third parties in any form whatever is not permitted without written authority from the proprietor. Property of FCI. Copyright FCI.