

REVISIONS					
P	LTR	DESCRIPTION	DATE	BYN	APVD
F	REV PER ECO	17-007041	5-16-17	CT	EO

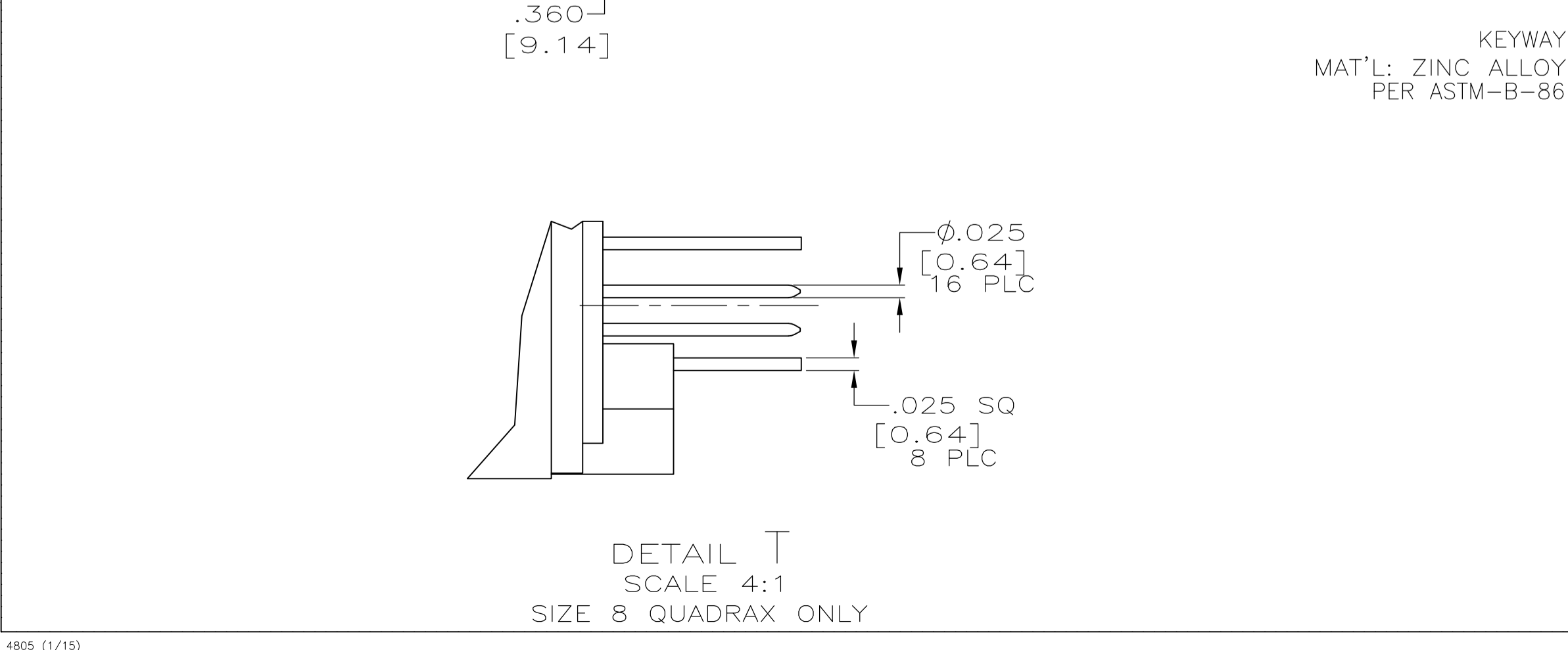
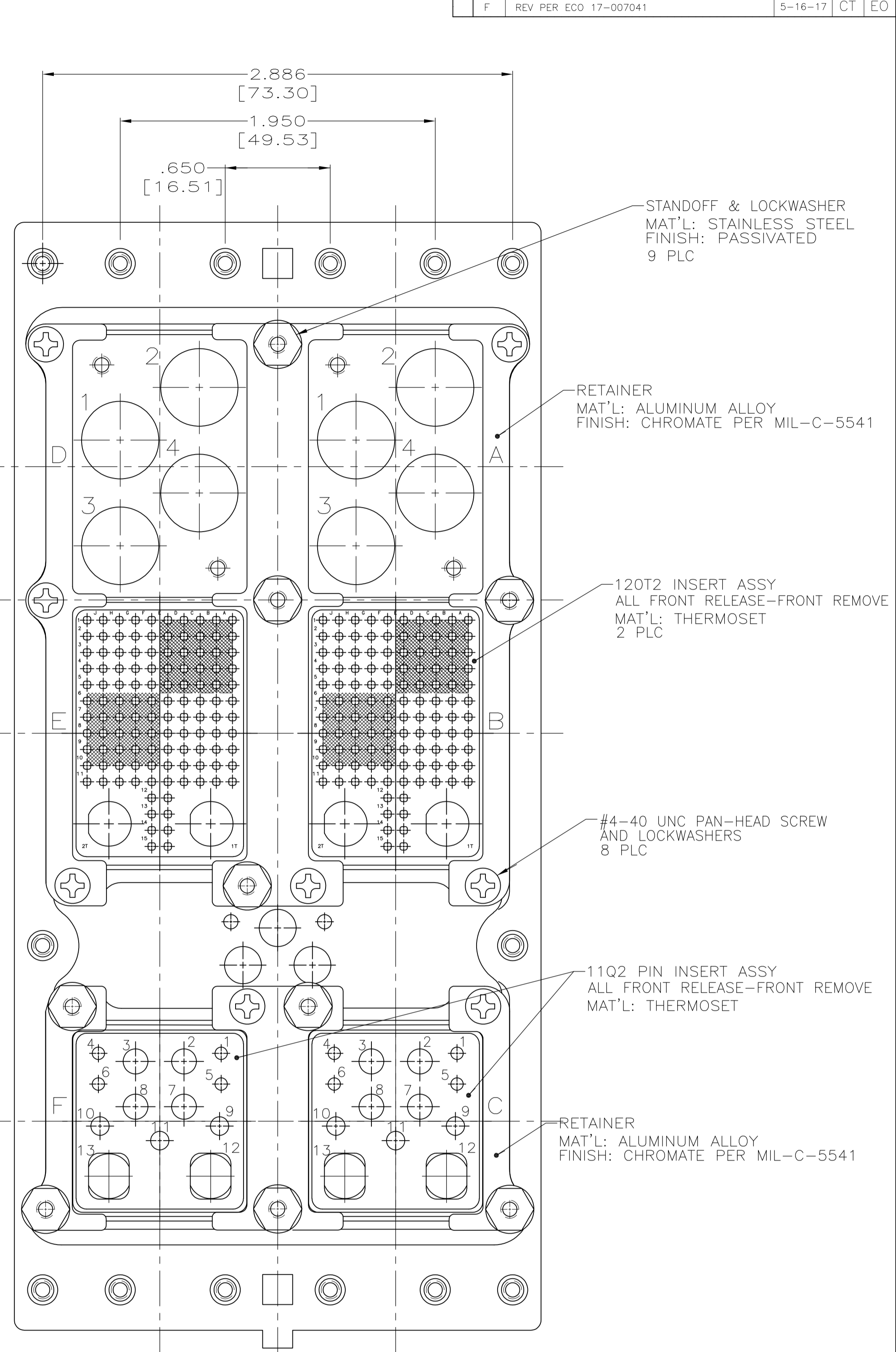
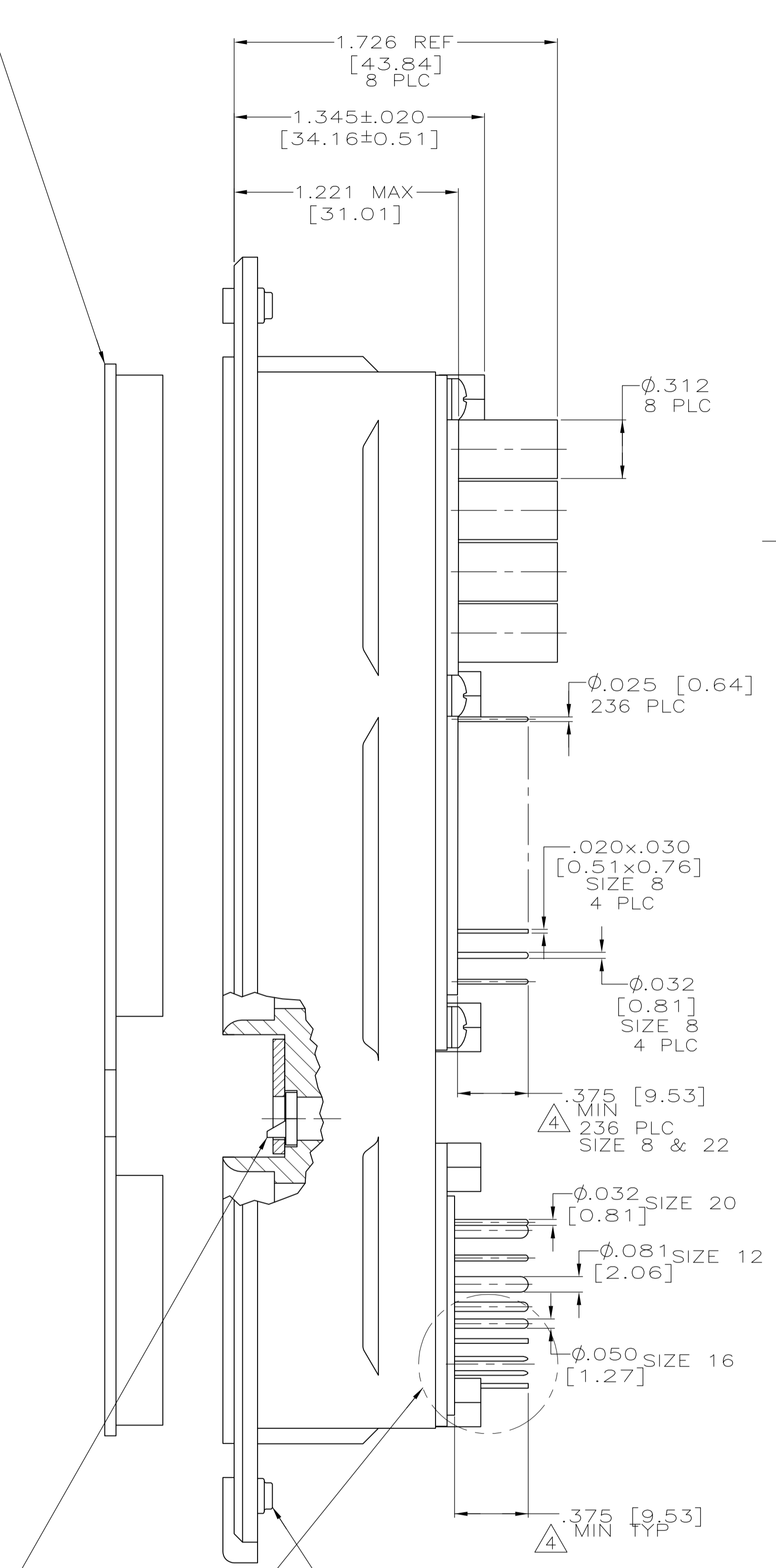
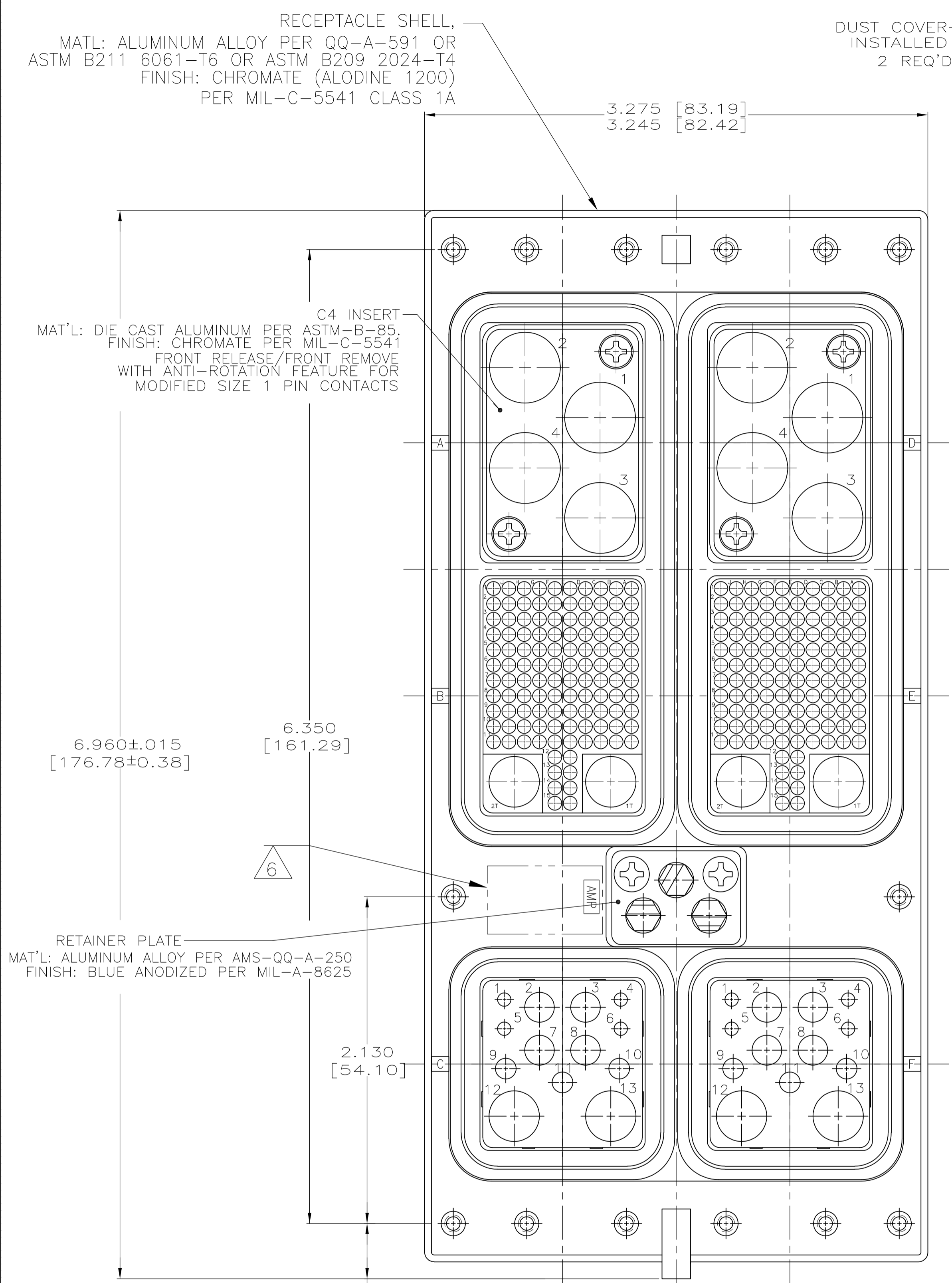

KEYING POSITION	CONTACTS INCLUDED AND INSTALLED	PART NUMBER
163	MODULE A & D 1218713-1 (SIZE 1/OSP, QTY=8) MODULE B & E 211431-6 (SIZE 22, QTY=236) 448540-3 (SIZE 8, QTY=4) MODULE C & F 448140-6 (SIZE 12 POSTED, QTY=8) 2-448138-6 (SIZE 20 POSTED, QTY=8) 448139-6 (SIZE 16 POSTED, QTY=6) 1445626-2 (SIZE 8 QUADRAX POSTED, QTY=4)	1663415-1

- CONNECTOR DIMENSIONS ARE PER ARINC 600 SPECIFICATION.
- CONNECTOR IS SUPPLIED WITH CONTACTS (PER TABLE) ASSEMBLED AS SHOWN.
- KEYING SHOWN IN POSITION "163" FOR ILLUSTRATION ONLY. CONNECTORS SHIPPED WITH KEYING INSTALLED IN POSITION PER TABLE. FOR POSITION "00" KEYING HARDWARE SHIPPED UNASSEMBLED.
- WITH CONTACT FULLY SEATED IN CAVITY.
- CONTACTS NOT SHOWN IN FRONT & REAR VIEWS FOR CLARITY.
- TE LOGO APPEARS IN THIS APPROXIMATE LOCATION ON MACHINED FROM BILLET SHELLS.
- ASSEMBLY SHOWN WITH DIE CAST SHELL. ASSEMBLIES WITH MACHINED SHELLS MAY VARY SLIGHTLY IN APPEARANCE.

THIS DRAWING IS A CONTROLLED DOCUMENT.		DIN C.C.THOMAS 5-6-03	TE Connectivity	
DIMENSIONS: INCHES		5-6-03		
TOLERANCES UNLESS OTHERWISE SPECIFIED:		APVD S.GLATFELTER 5-6-03	NAME	
0 PLC ± - 1 PLC ± - 2 PLC ± - 3 PLC ± .010 [0.25] 4 PLC ± - ANGLES ± -		PRODUCT SPEC		RECEPTACLE ASSEMBLY, SIZE 3, ARINC 600 WITH QUADRAX INSERTS
MATERIAL SEE CALLOUTS		FINISH SEE CALLOUTS	WEIGHT 0.000000	SIZE CASE CODE DRAWING NO. A1 00779 C=1663415
		CUSTOMER DRAWING		RESTRICTED TO
		SCALE 2:1		SHEET 1 OF 1
				REV F