

## Quad Precision Op Amp Evaluation Board

by Giampaolo Marino and Steve Ranta

### INTRODUCTION

The EVAL-PRAOPAMP-4R/4RU is an evaluation board which accommodates quad op amps in SOIC and TSSOP packages. It is meant to provide the user with multiple choices and extensive flexibility for different applications circuits and configurations.

This board is not intended to be used with high frequency components or high speed amplifiers. However, it provides the user with many combinations for various circuit types including active filters, instrumentation amplifiers, composite amplifier, and external frequency compensation circuits. For examples of application circuits refer to ADI amplifier data sheets under the applications section. This application note will present different implementations of filter design using quad amplifiers.

### STATE VARIABLE FILTER (INVERTING)

The SV filter uses two integrators and a summing amplifier to provide second-order low-pass, band-pass, and high-pass responses. A fourth op amp can be used to combine the existing responses and synthesize the notch or the all-pass responses.

This filter circuit can be easily constructed using the quad EVAL\_PRAOPAMP board and following the schematic in Figure 1.

Using the superposition principle, we write

$$V_{HP} = (-R6/R4)V_1 - (R4/R_{JUMP})V_{LP} + \left[ \frac{1 + (R4/R6) + (R4/R_{JUMP})}{1 + (R_{JUMP1}/R5)} \right] V_{BP}$$

Since A2 and A3 are integrators, we have:

$$V_{BP} = (-1/R8 C6s)V_{HP} \text{ and } V_{LP} = (-1/R13 C8)V_{BP}$$

After extended simplifications we have the following expressions:

$$\omega_o = \sqrt{(R4/R_{JUMP})} / \sqrt{(R8 C6 R13 C8)}$$

and

$$Q = \left\{ \frac{\left[ (1 + R_{JUMP1}/R5) \sqrt{(R4 R8 C6/R_{JUMP} R13 C8)} \right]}{(1 + R4/R6 + R4/R_{JUMP})} \right\}$$

$$H_{OHP} = -R4/R6, H_{OBP} = (1 + R_{JUMP1}/R5) / (1 + R6/R_{JUMP} + R6/R4), H_{OLP} = -R_{JUMP1}/R6$$

From the above expressions we observe that  $Q$  depends on the resistor ratio  $R_{JUMP1}/R5$ . We therefore expect  $Q$  to be much less sensitive to resistance tolerances and drift. Indeed, with proper component selection and circuit construction, the SV filter can easily yield dependable  $Q$ s in the range of hundreds. For best results, it is advisable to use metal film resistors and polystyrene or polycarbonate capacitors, and properly bypass the op amp supplies.

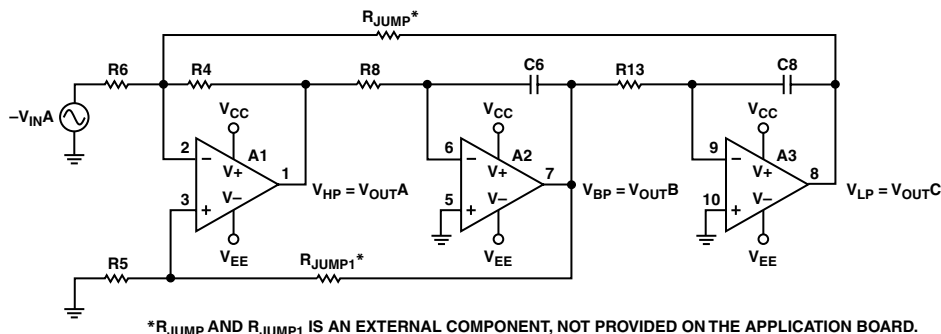

\*R<sub>JUMP</sub> AND R<sub>JUMP1</sub> IS AN EXTERNAL COMPONENT, NOT PROVIDED ON THE APPLICATION BOARD.

Figure 1. State Variable Filter (Inverting)

The SV filter is usually implemented with  $R4 = R6 = R_{JUMP}$ ,  $R8 = R13 = R$  and  $C6 = C8 = C$ . So, the above expressions simplify to

$$\omega_o = 1/RC \quad Q = 1/3 (1 + R_{JUMP}/R5)$$

$$H_{OHP} = -1 \quad H_{OBP} = Q \quad H_{OLP} = -1$$

The filter is tuned as follows:

1. Adjust  $R6$  for desired magnitude of the response of interest.
2. Adjust  $R8$  or  $R13$  to tune  $\omega_o$ .
3. Adjust the ratio  $R_{JUMP}/R5$  to tune  $Q$ .

### STATE VARIABLE FILTER (NONINVERTING)

Another popular type of state variable filter can be formed by just moving the input signal from the inverting to the noninverting side of A1, resulting in the noninverting state variable filter. See Figure 2.

By properly choosing the following components:

$$R4 = R6; R8 = R13; R5 = R_{JUMP}; C6 = C8$$

It can be shown that:

$$\omega_o = 1/R8C6 \quad Q = 1 + R_{JUMP}/R3$$

$$H_{OHP} = 1/Q \quad H_{OBP} = -1 \quad H_{OLP} = 1/Q$$

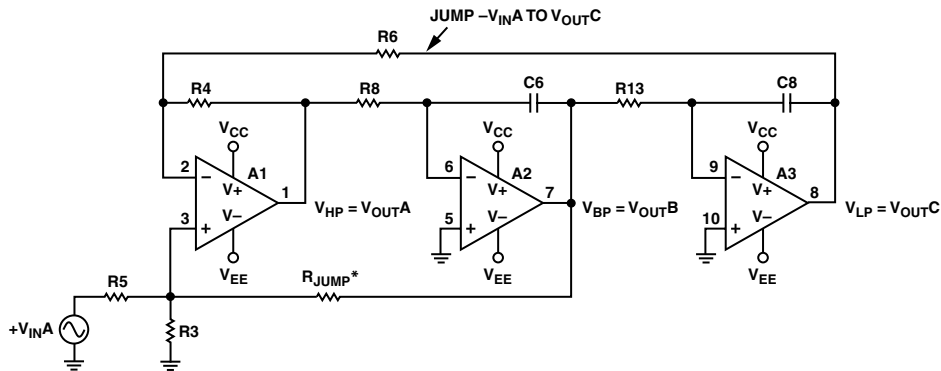

\*R<sub>JUMP</sub> IS AN EXTERNAL COMPONENT, NOT PROVIDED ON THE APPLICATION BOARD.

Figure 2. State Variable Filter (Noninverting)

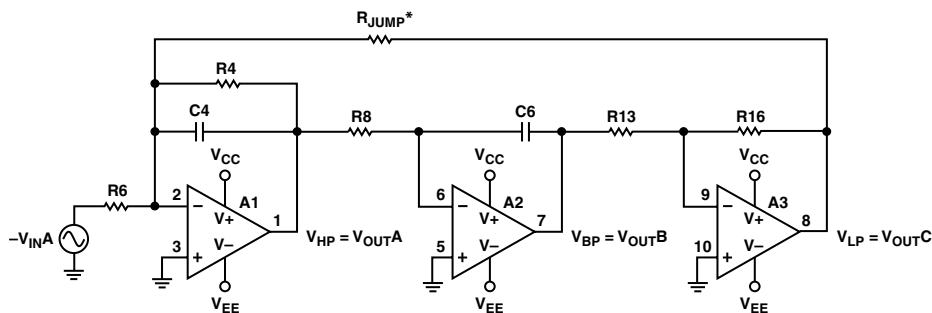

\*R<sub>JUMP</sub> IS AN EXTERNAL COMPONENT, NOT PROVIDED ON THE APPLICATION BOARD.

Figure 3. Biquad Filter

### THE BIQUAD FILTER

This particular filter implementation consists of two integrators. The third op amp is a unity gain inverting amplifier whose sole purpose is to provide polarity reversal.

Unlike the SV filter, the biquad yields only two significant responses; however, since all its op amps are operated in the inverting mode, the circuit is immune from common-mode limitations.

From the circuit above we have:

$$H_{OBP} = -R4/R6 \quad H_{OLP} = R_{JUMP}/R6$$

$$\omega_o = 1/\sqrt{(R8 R_{JUMP} C6 C4)} \quad Q = R4\sqrt{C4}/\sqrt{(R8 R_{JUMP} C6)}$$

The biquad filter is usually implemented with  $R8 = R_{JUMP} = R$   $C4 = C6 = C$ , after which the above expressions simplify as:

$$H_{OBP} = -R4/R6 \quad H_{OLP} = R/R6$$

$$\omega_o = 1/RC \quad Q = R4/R$$

This filter is tuned as follows:

1. Adjust  $R8$  or  $R_{JUMP}$  to tune  $\omega_o$ .
2. Adjust  $R4$  to tune  $Q$ .
3. Adjust  $R6$  for desired values  $H_{OBP}$  or of  $H_{OLP}$ .

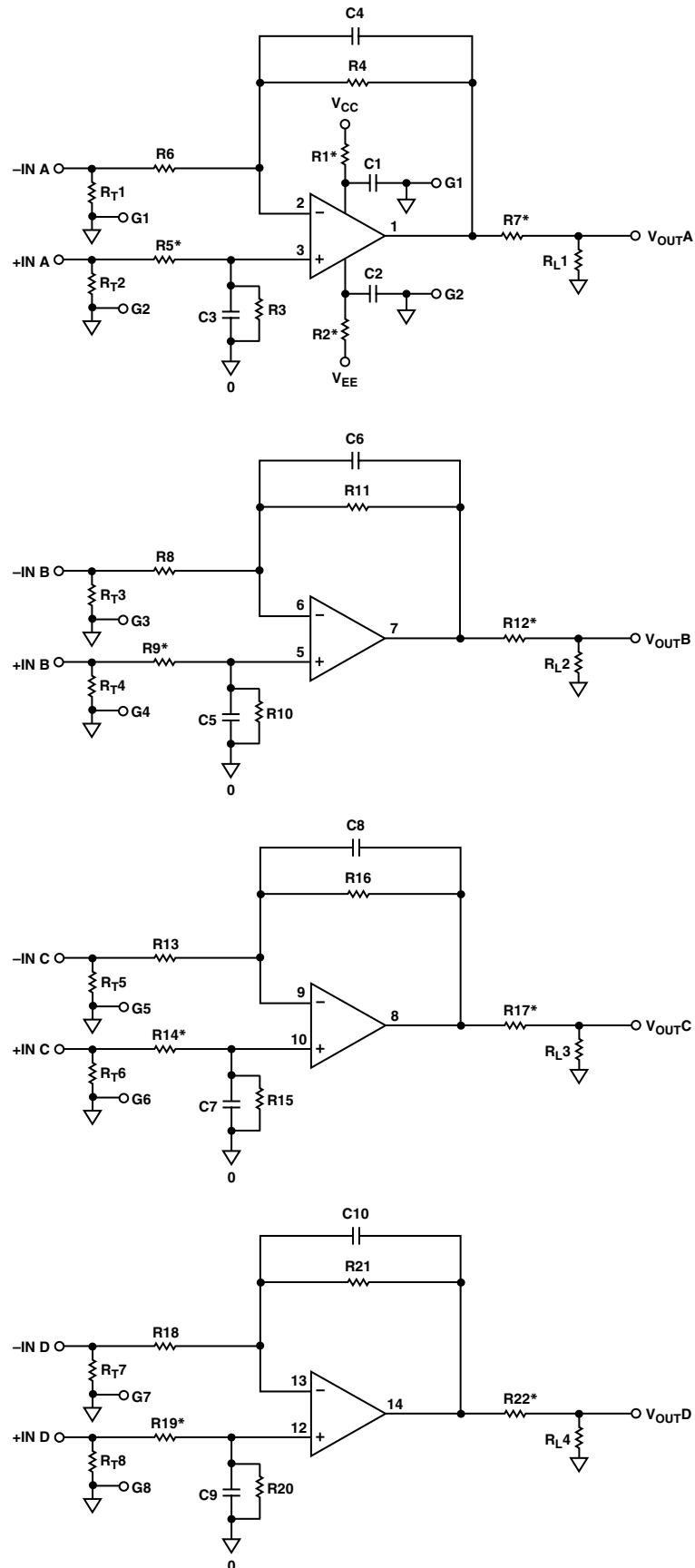

Figure 4. Quad Precision Op Amp Evaluation Board Electrical Schematic

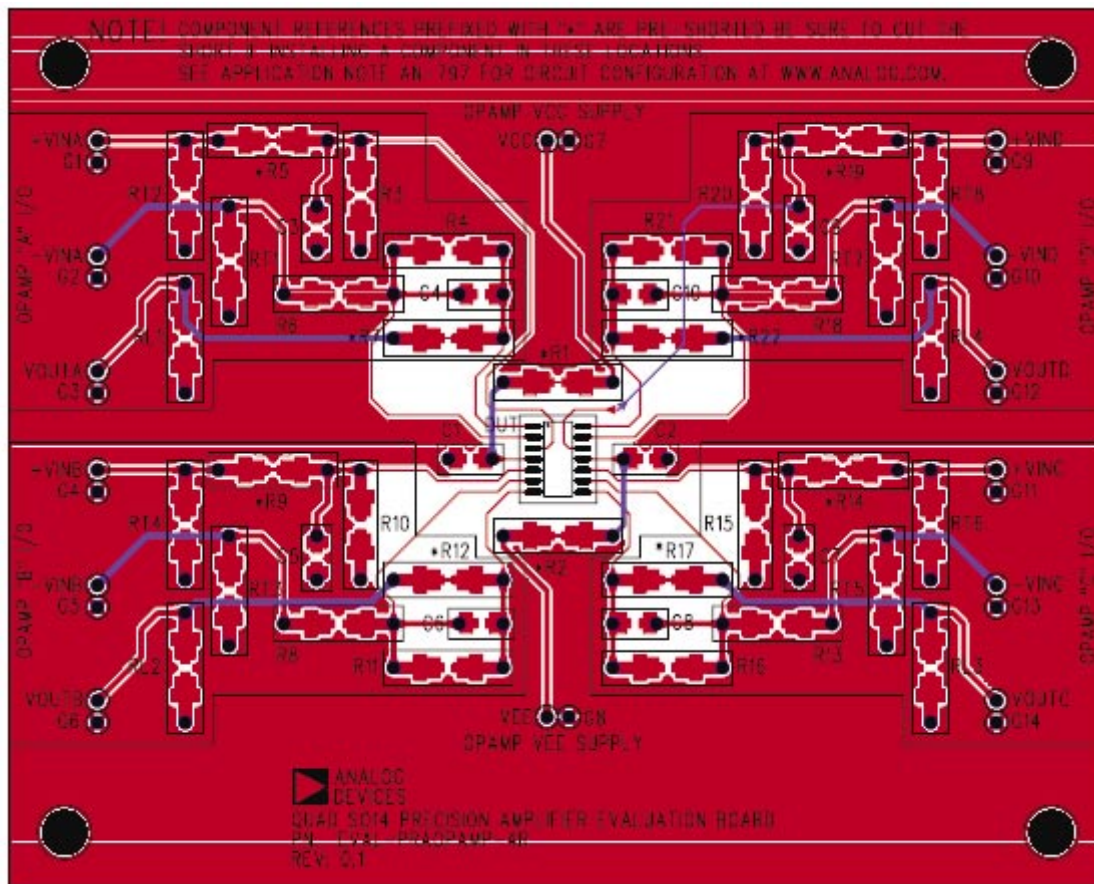

Figure 5. Quad Precision Op Amp Evaluation Board Layout Patterns

AN05566-0-12/05(0)