

PRODUCT NB	DIM"C"	DIM"D"	CAP	TAPE	TUBE	AVAILABILITY
95290-YXXLF	SEE SHEET 213 2/2		NO	NO	YES	SEE SHEET 213 2/2
95290-YXXALF			YES	YES	NO	SEE SHEET 213 2/2
95290-YXXBLF			YES	NO	YES	SEE SHEET 213 2/2
95290-YXXKLF			NO	YES	NO	SEE SHEET 213 2/2

PRODUCT NUMBER

95290-YXXZLF

PLATING CODE
SEE TABLE

RoHS COMPATIBLE, SEE NOTE 4 SHEET 2

OPTION LETTER (SEE TABLE & SHEET 2)
NUMBER OF POSITIONS, SHEET 2

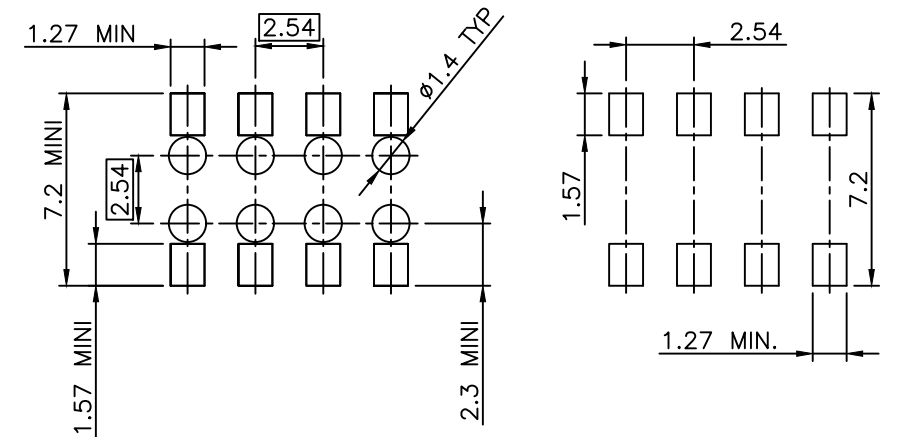
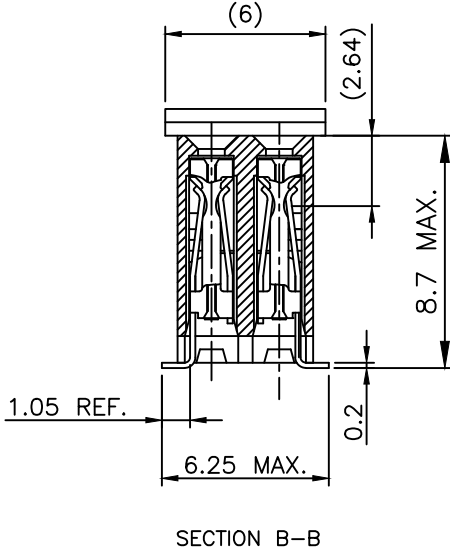
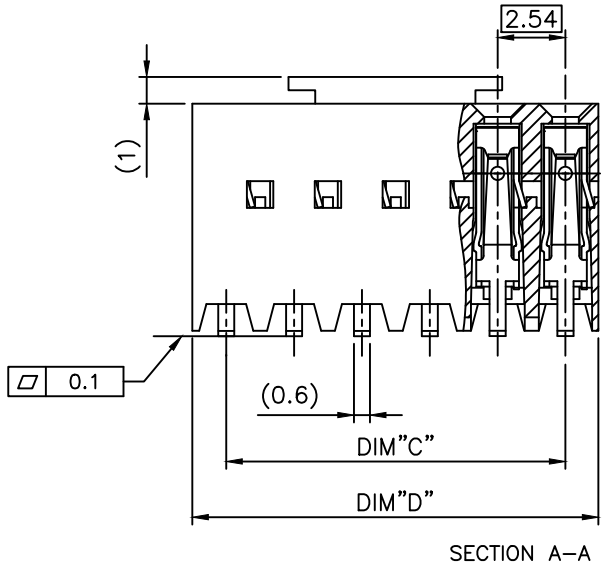
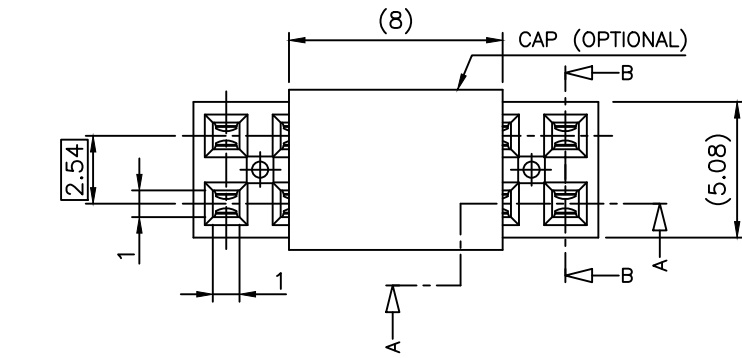

NOTES:

- 1 - MATERIAL HOUSING: HIGH TEMPERATURE THERMOPLASTIC, 30% GLASS FILLED COLOUR GREY, FLAME RETARDANT, PER UL-94-V0.
- 2 - MATERIAL TERMINAL: PHOSPHOR BRONZE EXTRA HARD



FCIconnect.com

Copyright FCI

95290-4XX(Z)LF	5µm Sn	Sn
95290-3XX(Z)LF	0.76µm GOLD	Sn
PLATING CODE	CONTACT AREA	SOLDER TAIL
	PLATING THICKNESS OVER 1.27µm Ni	

mat'l. code				surface		tolerance		projection	product family		
SEE NOTES				ISO 1302	ISO 406	ISO 1101			DUBOX VCC DR		
ltr	ecn no	dr	date	tolerances unless otherwise specified		±0.3		mm	title		
R	B-19923	BVE	15.01.08	angles	linear				BtB RECEPT.		
S	F-44214	LMU	22.03.21						VERT DR SMT 8.5 mm		
T	F-47995	DDE	23.04.12	±2'				scale 1/5	dwg no		
M	B-19123	LMU	14.10.21	dr	D.LEGRAND	97.01.13	FCI	sheet 1 of 2		size	
N	B-19232	LMU	14.10.28	enrg	P.NIZZI	97.01.13		95290		A3	
P	B-19535	BVE	14.11.24	appd	P.NIZZI	97.01.13		type		CUSTOMER	Drawing
sheet index	revision	T	K								

PRODUCT NUMBER	NUMBER OF POS.	DIM"C"	DIM"D"
95290-Y03(Z)LF	2 x 03	5.08	7.54
95290-Y04(Z)LF	2 x 04	7.62	10.08
95290-Y05(Z)LF	2 x 05	10.16	12.62
95290-Y06(Z)LF	2 x 06	12.70	15.16
95290-Y10(Z)LF	2 x 10	22.86	25.32
95290-Y22(B)LF	2 x 22	53.34	55.80

- 3 - OTHERS POSITIONS, ON SPECIAL REQUEST.
- 4 - RoHS COMPATIBLE PRODUCT SPECIFICATIONS
 - a - PLATING:
 - "LF" MEANS THE PRODUCT IS LEAD-FREE, 2µm MINIMUM MATTE TIN OVER 1.27µm MINIMUM NICKEL UNDERPLATE.
 - b - MANUFACTURING PROCESS COMPATIBILITY
 - THE HOUSING WILL WITHSTAND EXPOSURE TO 260°C PEAK TEMPERATURE FOR 30 SECONDS MAX IN A CONVECTION, INFRA-RED OR VAPOR PHASE OR REFLOW OVEN.
 - c - LABELING:
 - MEETS PACKAGING SPECS AS PER GS-14-920
 - d - LEGAL STATEMENT: SEE GS-47-0004



Copyright FCI

mat'l. code				surface		tolerance		projection		product family	
SEE NOTES				ISO 1302 ✓		ISO 406 ISO 1101				DUBOX VCC DR	
ltr	ecn no	dr	date	tolerances unless otherwise specified						title	
E	F04-037	DLE	04.11.16	linear		±x		mm		BtB RECEPT.	
F	F06-0204	DLE	06.06.28	linear		±xx		scale 1/5		VERT DR SMT 8.5 mm	
G	B-19123	LMU	14.10.21	σ±x'		±xxx				dwg no sheet 2 of 2 size	
H	B-19535	BVE	14.11.24	dr	D.LEGRAND	97.01.13				95290 A3	
J	B-19923	BVE	15.01.08	enfr	P.NIZZI	97.01.13				type CUSTOMER Drawing	
K	F-47995	DDE	23.04.12	chr	P.NIZZI	97.01.13					
				appd	P.NIZZI	97.01.13					
sheet index		revision sheet									