

DO NOT SCALE DRAWING
DIMENSION IN METRIC

LEAD FREE

DWG. NO.
SD 35718-09*0

SIMILAR ITEM

PROJECT NO.

C

B

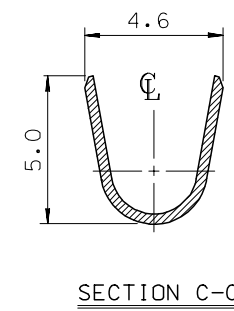
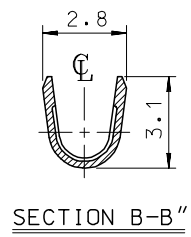
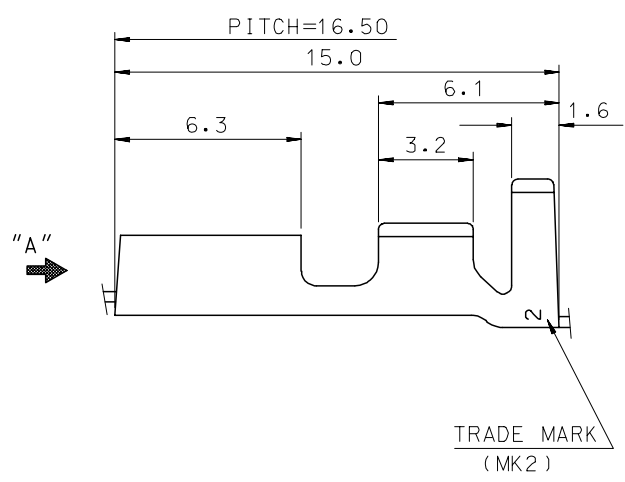
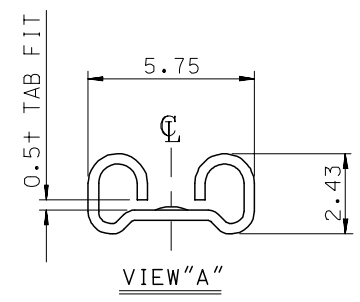
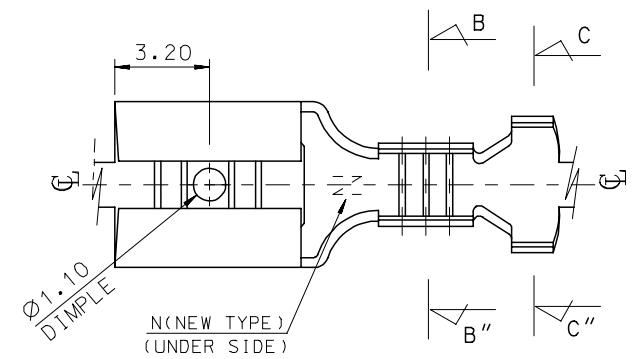

NOTES

1. MATERIAL : BRASS
2. FINISH : 35718-0900 : UNPLATED
35718-0910 : POST - TIN PLATED
35703-0260 : TIN PLATED (LEAD FREE)
3. APPLICABLE WIRE RANGE : AWG #20 - #16

REVISED EC NO. K0R2005-0180 DRWN: D.Y.JANG (05/04/12) CHK: Y.SIKKIM (05/04/12) APPR: C.W.LEE (05/04/12)	DESCRIPTION MAJOR = 0 CRITICAL C = 0	QUALITY SYMBOLS		GENERAL TOLERANCES: (UNLESS SPECIFIED)		SCALE 6 : 1	DESIGN UNITS <input checked="" type="checkbox"/> MM <input type="checkbox"/> INCH	THIRD ANGLE PROJECTION		DIMENSIONS: <input type="checkbox"/> MM <input type="checkbox"/> INCH <input type="checkbox"/> MM <input checked="" type="checkbox"/> ONLY		SHT	REV
		4 PLACES	±0.	±.	mm	INCH	DRAWN BY & DATE W.Y.YANG 93.05.24	TITLE: .187 SLIP-ON RECEPTACLE					
D	REV	3 PLACES	±0.	±.		CHECKED BY & DATE B.K.CHOI 93.05.24	MATERIAL NO. SEE NOTES						
		2 PLACES	±0.20	±.		APPROVED BY & DATE C.W.LEE 93.05.24	DRAWING NO. SD-35718-09*0						
		1 PLACE	±0.30	±.		CAD FILENAME S7180900.DGN	MATERIAL NO. SEE NOTES		DRAWING NO. SD-35718-09*0		SHEET NO. 1 OF 1		
		ANGULAR: ± 1 °				DRAFT WHERE APPLICABLE MUST REMAIN WITHIN DIMENSIONS		THIS DRAWING CONTAINS INFORMATION THAT IS PROPRIETARY TO MOLEX INCORPORATED AND SHOULD NOT BE USED WITHOUT WRITTEN PERMISSION.					

MX-A3