



ANATECH ELECTRONICS INC
RF & Microwave Filters & Products

**1525-1559.5 MHz / 1626-1660.5 MHz
Ceramic Duplexer**

Part Number: AM1542-1643D1120



<u>Characteristics</u>	<u>Band 1</u>	<u>Band 2</u>
Passband:	1525-1559.5 MHz	1626-1660 MHz
Bandwidth:	50 MHz	34 MHz
Passband Return Loss:	17 dB	18 dB
Passband Insertion Loss:	1 dB	1.1 dB
Passband Ripple:	0.3 dB	0.3 dB
Input / Output Impedance:	50 Ohms	50 Ohms
Isolation:	59 MHz	66 MHz
Power Handling:	5 W max	5 W max

<u>Mechanical</u>	
Mounting Method:	SMT
Dimensions:	40.2 x 8.5 x 8.2 mm

<u>Environmental</u>	
Operating Temperature:	-40 to +70 deg.C
Storage Temperature:	-50 to +90 deg.C

This product is RoHs compliant.

Outline Drawing:

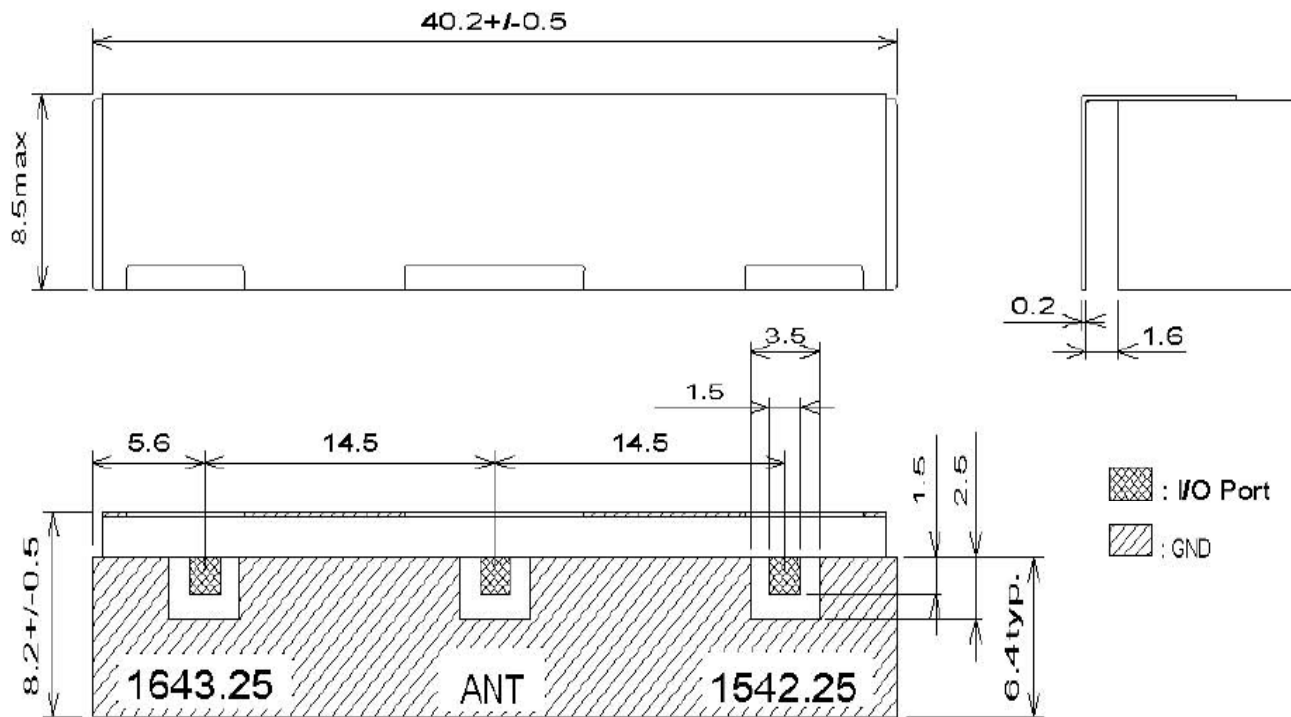



ANATECH ELECTRONICS INC
RF & Microwave Filters & Products

1525-1559.5 MHz / 1626-1660.5 MHz Ceramic Duplexer

Part Number: AM1542-1643D1120



Response Plot:

