



ANATECH ELECTRONICS INC
RF & Microwave Filters & Products

9700 MHz Cavity Band Pass Filter

Part Number: AE9700B11603



Electrical Specifications

Center Frequency: 9700 MHz
1dB Bandwidth: 1500 MHz
Insertion Loss: 2.5dB Max.
Return Loss: 11dB Min.
Rejection1: ≥50dB @ 6700 MHz
Rejection2: ≥ 50dB @ 12700 MHz
Impedance: 50 Ohms
Power Handling: 1 W

Mechanical

Mounting Method: 2mm Through Holes
Connector Type: SMA(F)
Dimensions: 1.72 X 0.67 X 0.43 in.

Environmental

Operating Temperature: -40°C to +70°C
Storage Temperature: -50°C to +80°C
Shock: 20 G. 11ms
Vibration: 20 G. 5 to 200Hz

Outline Drawing:

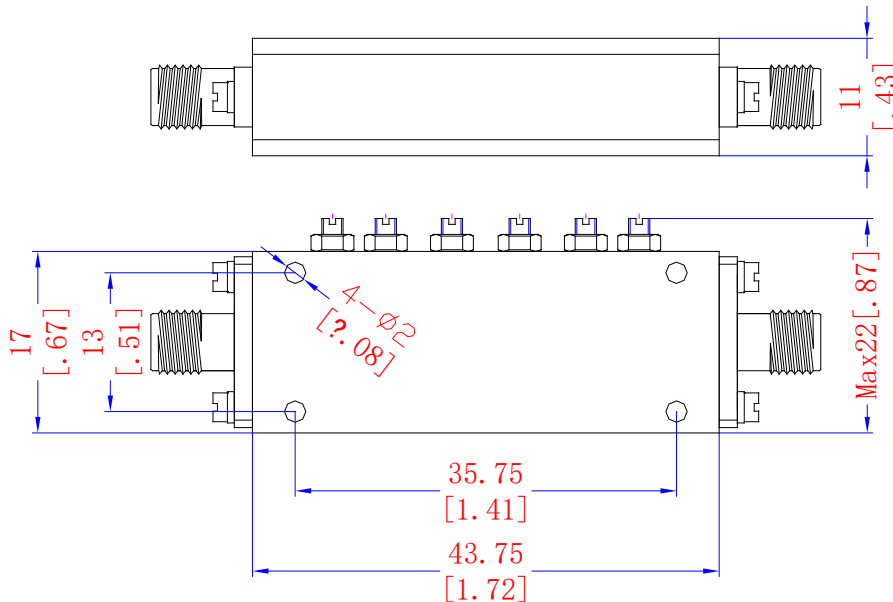

Tolerance: +/-0.01 inches [+/- 0.3mm]

Angles: +/- 1 Deg.

*Tolerance as shown unless otherwise specified in the datasheet electrical specification tables above.

*When max dimensions are called out the above tolerances do not apply as long as it is under the max call out.

70 Outwater Lane Phone: (973) 772-4242
Garfield, NJ 07026 Fax : (973) 321-3941

Email: sales@anatechelectronics.com
Web: www.anatechelectronics.com



Simulation Plot:

RFQ-20190208-BPF-9700 MHz-1500 MHz

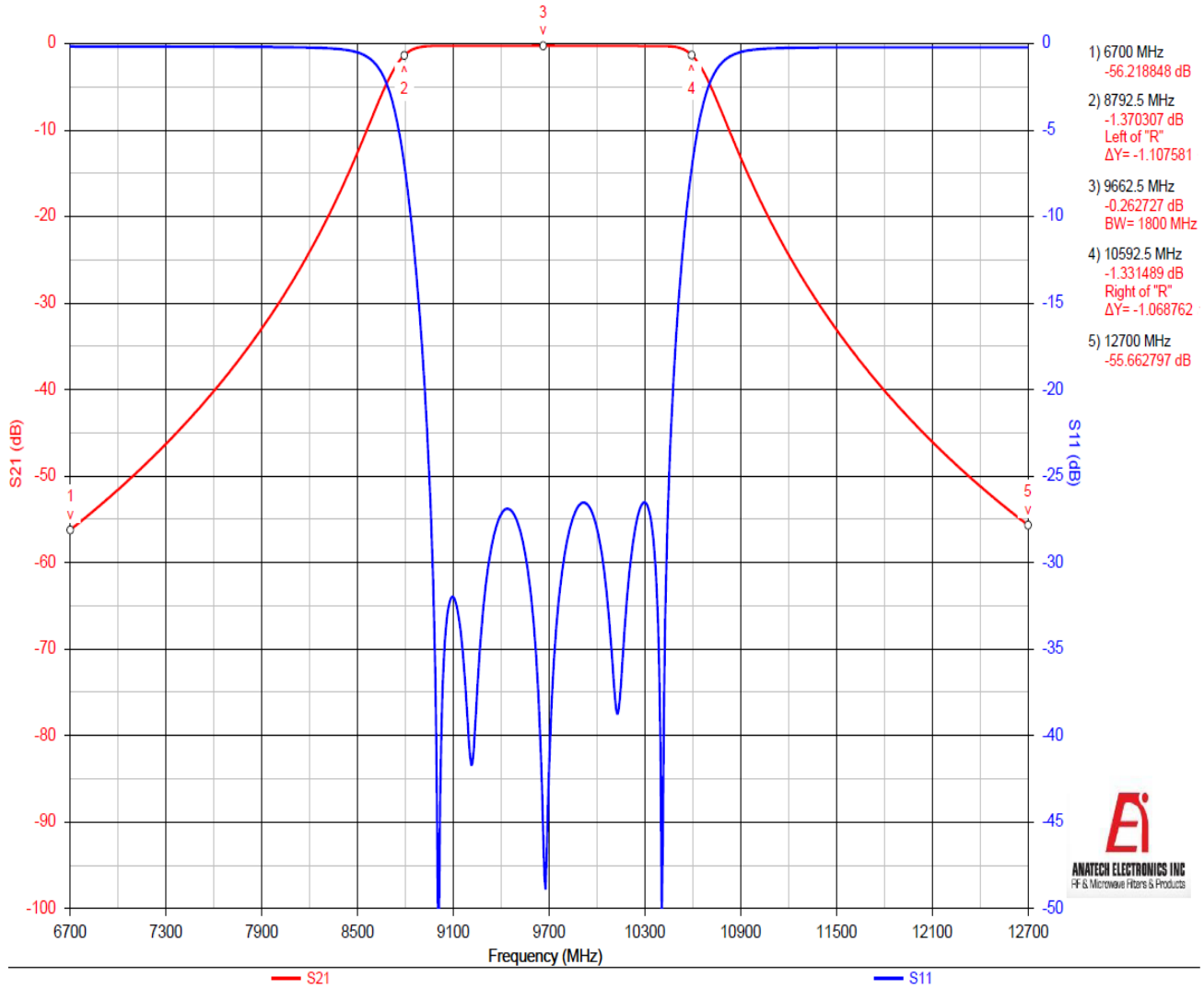

Note: This is a simulation Plot. Actual response plot might differ once product is manufactured.