

THIS DRAWING IS UNPUBLISHED. RELEASED FOR PUBLICATION
 © COPYRIGHT - By - ALL RIGHTS RESERVED.

REVISIONS					
P	LTR	DESCRIPTION	DATE	DWN	APVD
	H	REL -1 PER 0G3A-0648-00	04OCT00	JR	MS
	H1	REVISED PER ECO-16-017419	13MAR2017	RS	DR

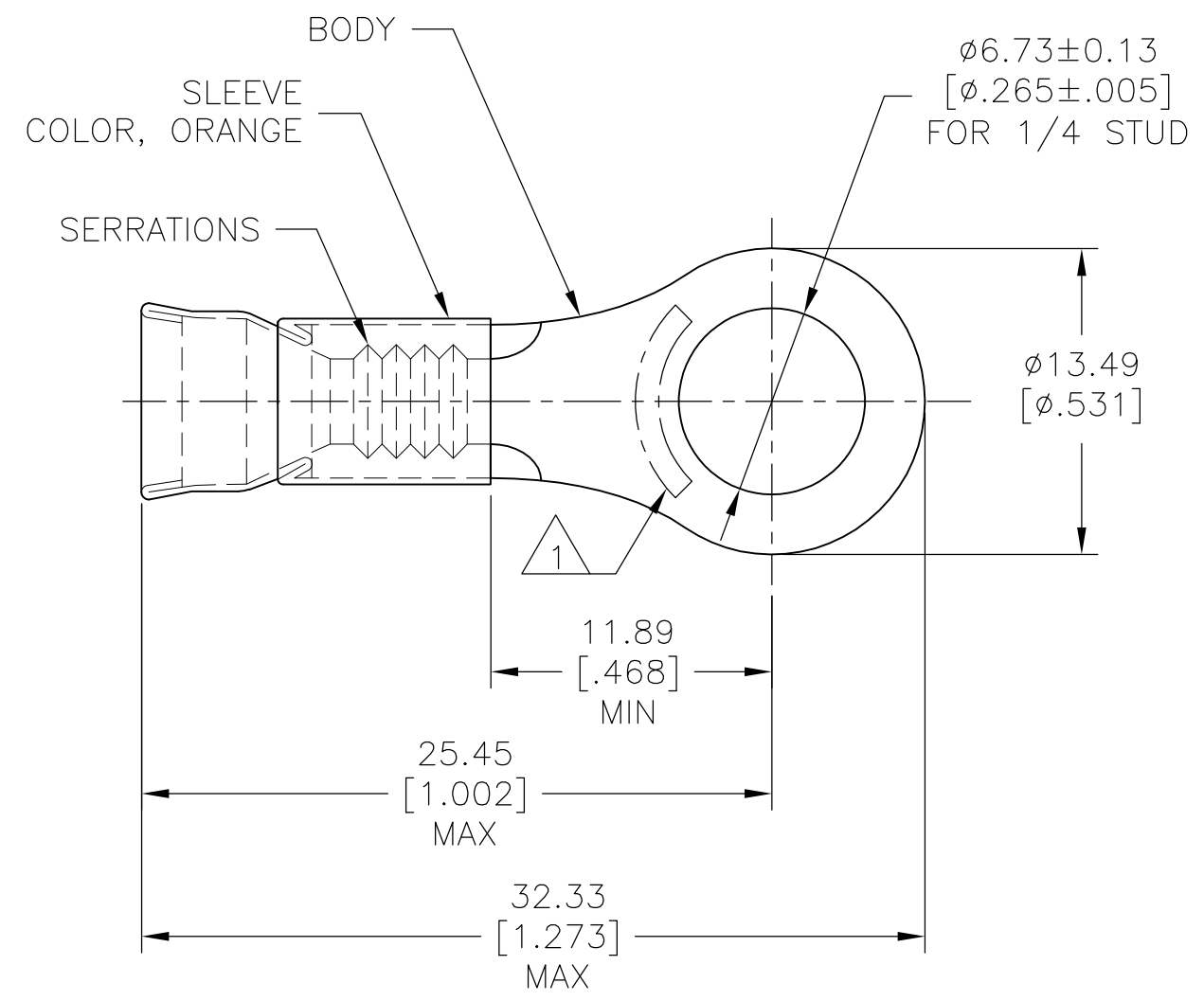

- 1 STAMP AMP 12-10 APPROX AS SHOWN.
- 2 WIRE INSUL DIA, ø3.81-5.84 [ø.150-.230].
- 3 TONGUE MATL THK, 1.02±0.05[.040±.002].
- 4 NO ORANGE COLOR CODE ON BARREL TO DENOTE NICKEL MATERIAL.
- 5 PRELIMINARY - NOT FOR PRODUCTION.

4	2,500	ON TAPE, REEL	5	323751-2
	500	LOOSE PIECE		323751
	QTY	PACKAGE TYPE		PART NO

AMP INCORPORATED CUSTOMER SERVICE SYSTEM		MAX RECOMMENDED OPERATING TEMPERATURE: 649°C [1200°F]	THIS DRAWING IS A CONTROLLED DOCUMENT.		DWN L OLMEDA 10OCT94	TE Connectivity			
FOR ADDITIONAL PRODUCT INFORMATION OR COPIES OF DRAWINGS AND TECHNICAL DOCUMENTS	PRODUCT INFORMATION CENTER 1-800-522-6752	VOLTAGE RATING: -	DIMENSIONS: mm [INCHES]	TOLERANCES UNLESS OTHERWISE SPECIFIED:	CHK M ELLIS 10OCT94				
FOR APPLICATION TOOLING INFORMATION	TOOLING ASSISTANCE CENTER 1-800-722-1111	CIRCULAR MIL AREA: 2.62mm ² -6.64mm ² [5180-13100] STRANDED WIRE		0 PLC ± -	APVD S BORTNER 10OCT94	PRODUCT SPEC			
FOR ORDER ENTRY	1-800-526-5142	MATERIAL BODY, NI PER ASTM B162 SLEEVE, NI SIL PER ASTM B122		1 PLC ± -	2 PLC ± 0.20 [.008]	PRODUCT SPEC	SIZE	CAGE CODE	DRAWING NO
					3 PLC ± -	APPLICATION SPEC			
					4 PLC ± -	WEIGHT -			
					ANGLES ± -	A3 00779 C-323751			
					FINISH -	CUSTOMER DRAWING SCALE 4:1 SHEET 1 OF 1 REV H1			